



SUPPLEMENT INSTALLATION INSTRUCTIONS FOR

“Countershaft Driven” Power take-off on Earlier UltraShift RTO-**910B-DM2 Series Transmission

Electrical Interface Requirements

All countershaft driven power take-off's mounted on an Eaton UltraShift DM transmission must provide an electrical interface with the transmission. The standard PTO mounted switch can be used to activate the PTO operating mode of the transmission. This feature uses pin F1 of the 18-way transmission connector DM2 or pin 18 on the 38-way connector DM3. See the figure below for countershaft driven PTO electrical interface diagram. Review vehicle manufacturer's body builder's manuals for location of wire connected to F1 on the Eaton connector.

The Eaton UltraShift DM transmission must have an input signal from the countershaft driven Power Take-off when it is active. In this active state, the clutch engagement is controlled when the operator raises the engine speed to engage the clutch and drive the transmission main box countershaft. Incorrect or no PTO interface signal to the transmission will result in uncontrolled engagement of the clutch during PTO operation.

The active signal will illuminate the “Mode” indicator on the Push Button Console. The input signal wire for the PTO must be isolated from other PTO related circuits.

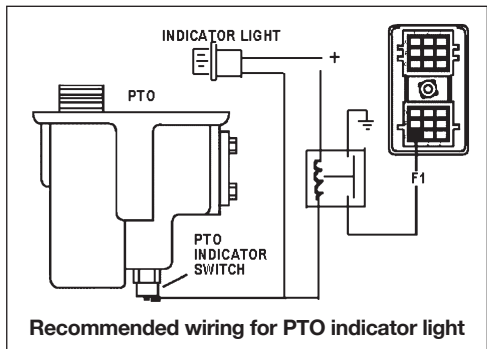

From	To	Wire Description
**F1	PTO+	PTO+

**PIN 18 ON DM3

Front View
Transmission ECU Connector
(Vehicle Interface)

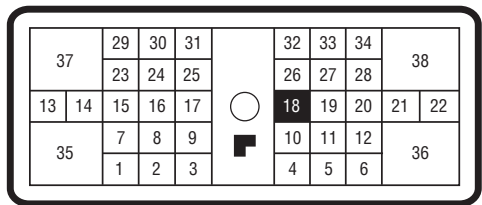

Pin Side View

*Eaton Manual Available Online at <http://www.truck.eaton.com/na/>

Relocation Instructions to Move Inertia Brake from 8-Bolt to 6-Bolt PTO Opening

Removal



CAUTION: Oil may be hot.

Note: Drain the lubricant from the transmission. Drain the lubricant from the related circuits Inertia Brake. On older product the Inertia Brake will still remain full of lubricant (no drain plug).

1. Disconnect the Transmission Harness from the Inertia Brake Coil and remove tie straps restraining this harness branch.

Note: Use care not to damage the harness.

2. Disconnect the lubricant supply line from the Inertia Brake.



CAUTION: The inertia brake is heavy. Be prepared to handle the weight of the inertia brake when the mounting bolts are removed.

3. Remove the six (6) mounting bolts from the inertia brake.
4. Remove the inertia brake and gasket from the adapter plate.
5. Remove the eight (8) mounting bolts from the adapter plate.
6. Remove and discard the adapter plate and gasket from the transmission.
7. Remove the six (6) mounting bolts from the 6-bolt PTO cover.
8. Remove and discard the 6-bolt PTO cover and gasket from the transmission.

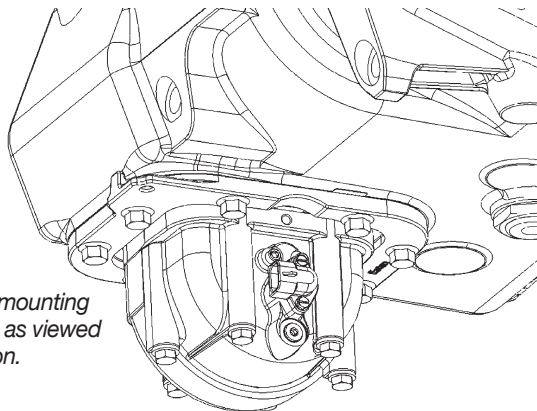

Standard Inertia Brake mounting to 8-bolt PTO opening, as viewed from rear of transmission.

Note: Clean and remove all old gasket material from the mating surfaces of the inertia brake and transmission PTO coverings. Locate the harness push-in anchor point for reference during re-installation to 6-bolt opening.

Instructions

1. Clean and thoroughly dry all mating surfaces (including the gasket prior to assembly).

Note: The transmission inertia brake may be mounted to the 6-bolt PTO opening directly, or mounted utilizing a 6-bolt PTO Angle Adapter to assist in aiding chassis clearance.

2. If a 6-bolt PTO Angle Adapter is required, install the angle adapter to the 6-bolt PTO opening following the manufactures instructions.
3. Inertia brakes installed with the angle adapter require a new lubrication hose (not supplied). Eaton part number 5588210
4. Using the six inertia brake cap screws, install the inertia brake and special gasket, being careful to align the inertia brake gear with the drive gear. Tighten mounting bolts to 40-45 ft.lbs. (54-61 Nm) using a cross pattern.

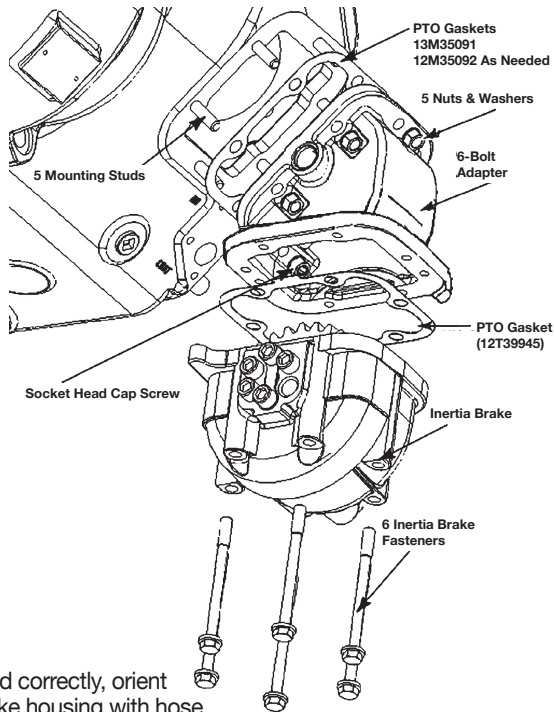

Note: When mounted correctly, orient the inertia brake housing with hose connection forward/electrical connection rearward, same orientation as 8-bolt.

- When mounted to a 6-bolt PTO Angle Adapter—orient the inertia brake housing with hose connection rearward/electrical connection forward.
- Ensure gasket, inertia brake and mating mounting faces are assembled dry (no lubricant or grease).



CAUTION: The inertia brake is heavy. Be prepared to handle the weight of the inertia brake until the mounting bolts are installed.

5. Reconnect the lubricant supply line to the inertia brake and tighten to 20-22 ft.lbs. (27-30 Nm).
6. Reroute and reconnect the transmission harness to the inertia brake coil. Dress the harness along the transmission case from the inertia brake up to the top of the transmission. Install the harness push-in anchor to the threaded-hole anchor point in the inertia brake housing. Install tie wraps (not supplied) every 6-10 inches. The harness should not have sharp bends or be under tension.
7. Install the PTO to the 8-bolt PTO opening following the manufacturer's instructions.

Note: Fill the transmission with lubricant.

Final Check

- Make sure the mounting bolts are properly tightened.
- Make sure the lubricant supply line is properly tightened.
- Make sure the transmission is properly filled with lubricant.
- Make Sure the transmission harness is connected and locked.
- Check for lubricant leaks after operating the vehicle.
- Check that the inertia brake has sufficient clearance to prevent contacting tanks, brackets, frame rails, exhaust or any other part of the vehicle. Contacting anything when stationary or moving will cause damage to inertia brake, angle adapter or other vehicle equipment.



**Muncie[®]
Power
Products**

A Member of the Interpump Group

201 East Jackson Street, Muncie, Indiana 47305
800-367-7867 • Fax: 765-284-6991
info@munciepower.com

Specifications are subject to change without notice.
Visit www.munciepower.com for warranties and literature.
All rights reserved. © Muncie Power Products, Inc. (2007)