

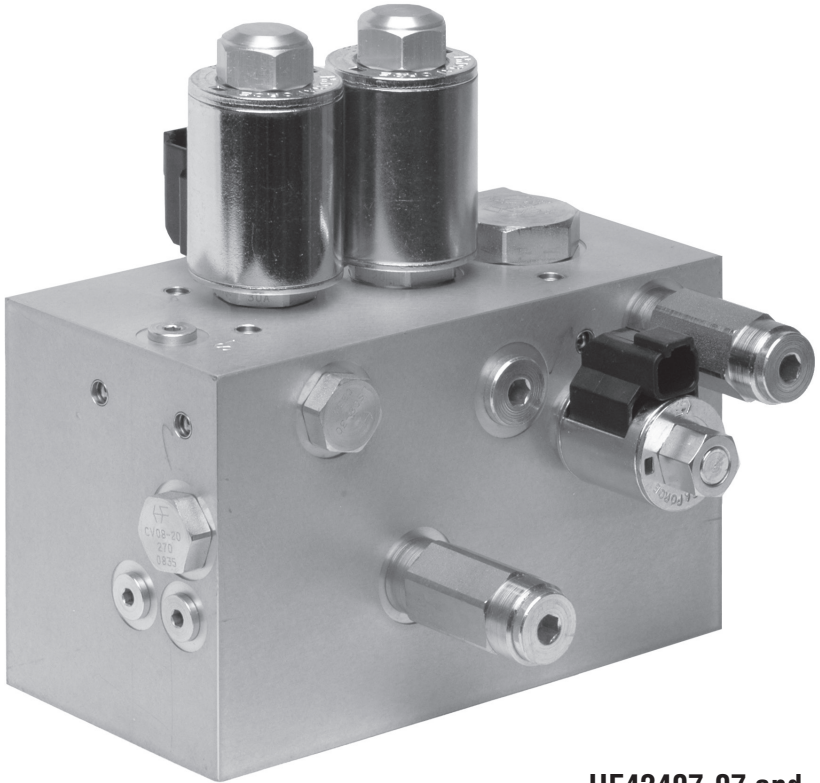

MESP-202H

INSTALLATION INSTRUCTIONS AND OWNER'S MANUAL

FEATURES • VALVE FUNCTIONS • ADJUSTMENTS • SCHEMATICS



**HF42407-07 and
HF51912-09**

TABLE OF CONTENTS

<u>DESCRIPTION</u>	<u>PAGE</u>
Features	3
Hydraulic Specifications	3
Original MESP 202H Workports.....	4
Revised MESP 202H Workports	5
Original Cartridge Designations, Function, and Part Numbers.....	6
Original “Open Center” Schematic.....	7
Original “Load Sense” Schematic	8
Revised Cartridge Designations, Functions, and Part Numbers	9
Revised “Open Center” Schematic	10
Revised “Load Sense” Schematic.....	11
Relief Valve Adjustment	12
Detailed Description of MESP-202H	13-15

Original MESP202H — HF42407-07

Revised MESP202H — HF51912-09

* Changes to revised model:

1. Eliminated CV2 (HF42407-07)
2. Moved PGP gage port from side (on HF42407-07) to front face.

MESP-202H FEATURES

FOR GEAR PUMP APPLICATIONS

Unloader for low pressure loads when not operating equals low heat and low energy consumption.

DIRECT ACTING SOLENOID PROPORTIONAL VALVES

For consistent and predictable flow control.

POST PRESSURE COMPENSATION

Flow stability under varying load.

VERSATILE 2 DESIGN OPTIONS

Load Sense (variable displacement pumps) or Open Center (fixed displacement pumps).

2 ADJUSTABLE RELIEF VALVES

One inlet relief and one output relief.

HYDRAULIC SPECIFICATIONS

Maximum Inlet Flow	30 GPM
Maximum System Pressure	3,000 PSI
Unloaded Pressure Drop.....	40 PSI AT 25 GPM
Auger Flow (Proportional)	15 GPM <i>(Pressure Compensated)</i>
Spinner Flow (Proportional)	7 GPM <i>(Pressure Compensated)</i>
Main Relief	Factory Setting 2,200 <i>(PSI Adjustable)</i>
Spreader Relief	Factory Setting 2,000 <i>(PSI Adjustable)</i>

ORIGINAL MESP-202H WORKPORTS

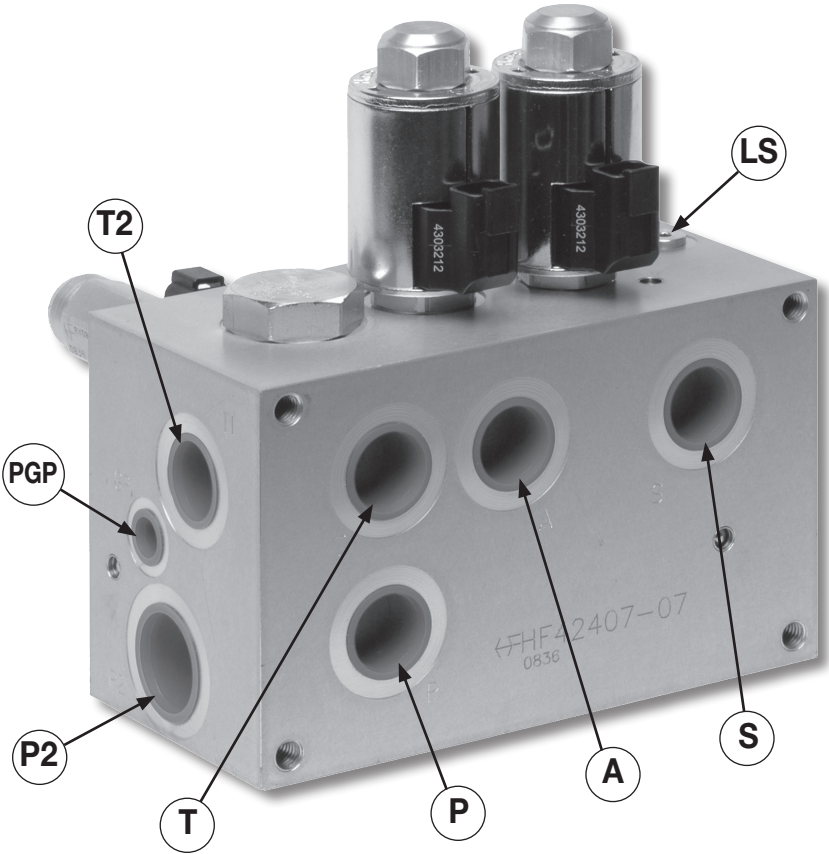

HF42407-07

DESIGNATION	DESCRIPTION	SIZE (SAE)
T	TANK	12
T2	TANK	12
P	PUMP	12
P2	PUMP	16
A	AUGER	12
S	SPINNER	12
LS	LOAD SENSE	4
PGP	PUMP GAGE PORT	6

REVISED MESP-202H WORKPORTS

APRIL 1, 2009

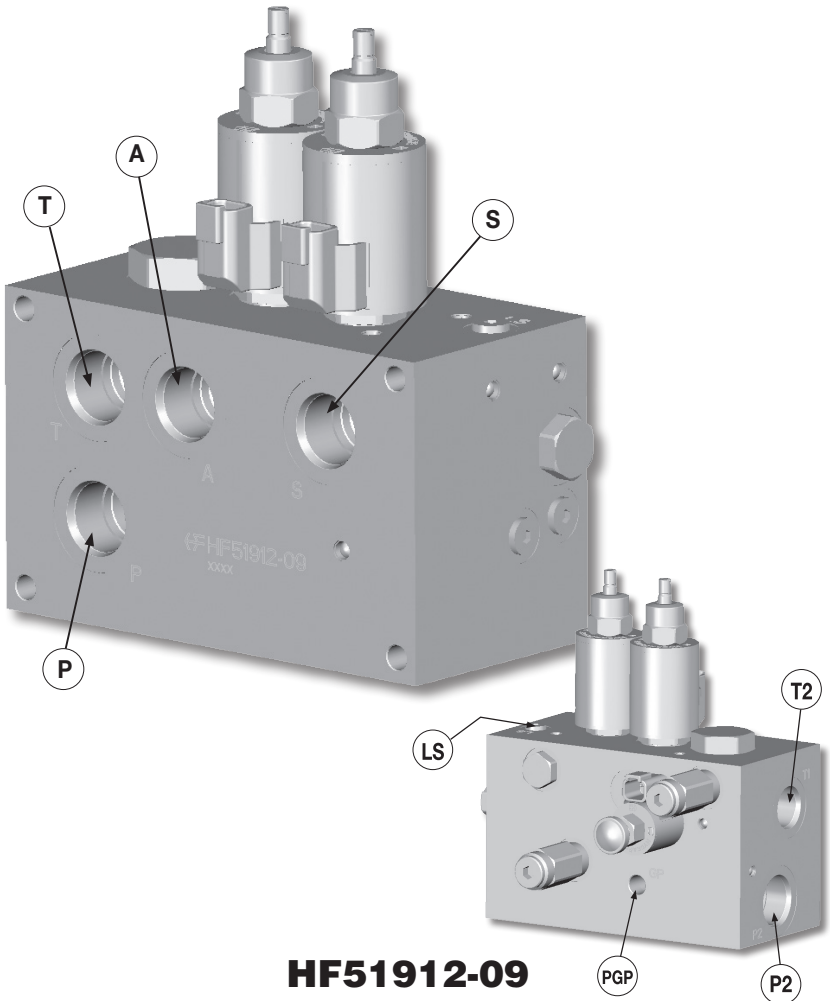

HF51912-09

DESIGNATION	DESCRIPTION	SIZE (SAE)
T	TANK	12
T2	TANK	12
P	PUMP	12
P2	PUMP	16
A	AUGER	12
S	SPINNER	12
LS	LOAD SENSE	4
PGP	PUMP GAGE PORT	¼" NPTF

ORIGINAL MESP-202H MANIFOLD

CARTRIDGE DESIGNATIONS, FUNCTIONS, & PART NUMBERS

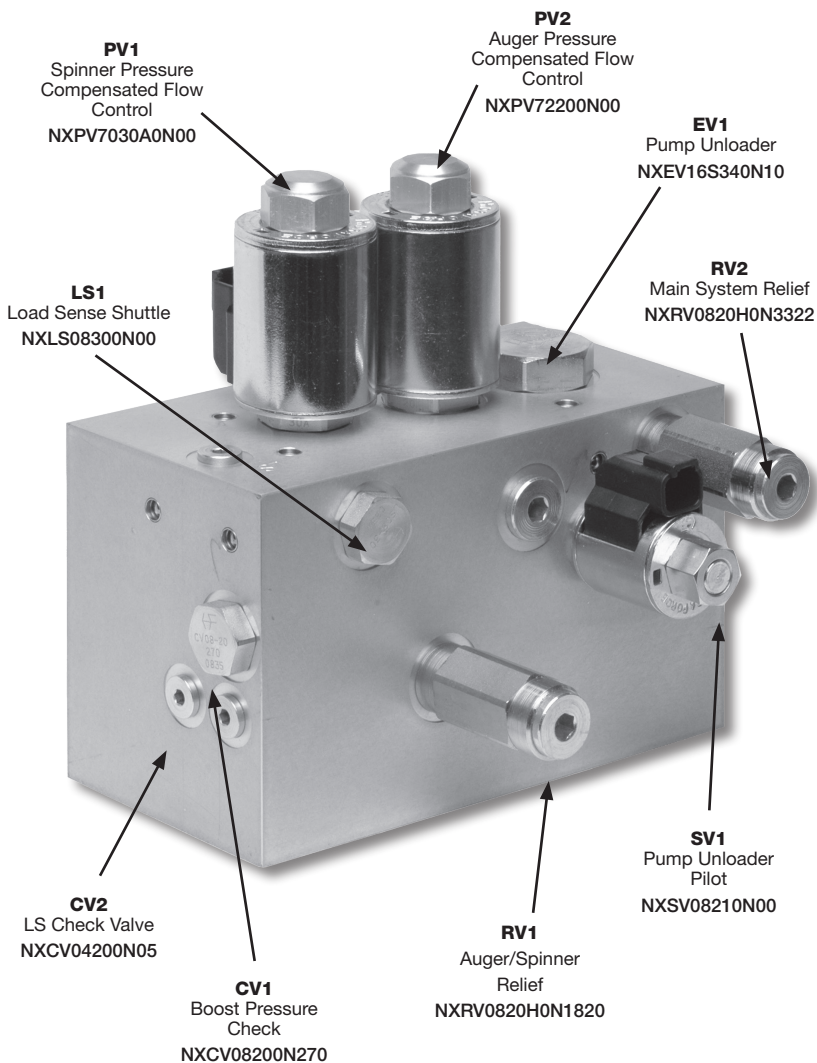

HF42407-07

COIL	PART NUMBERS
SV1	NX4303612
PV1	NX4303212
PV2	NX4303212

ORIGINAL MESP-202H "OPEN CENTER" SCHEMATIC

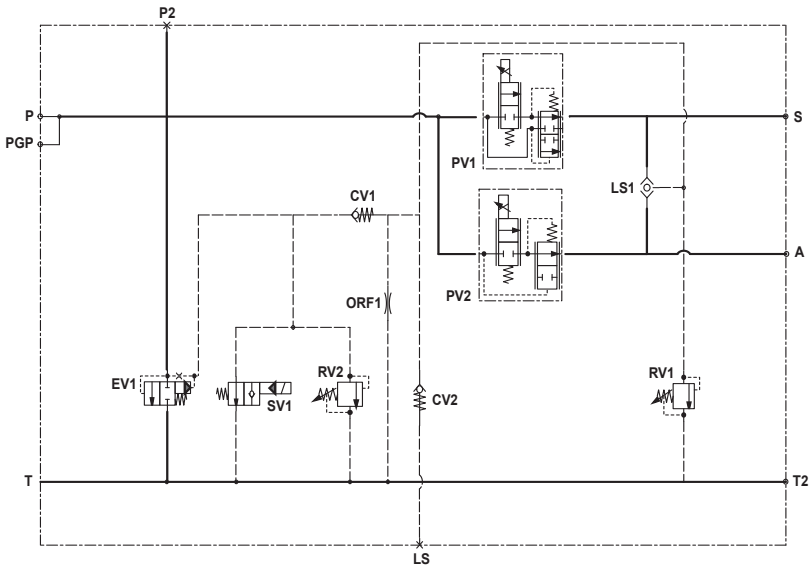

HF42407-07 VALVES

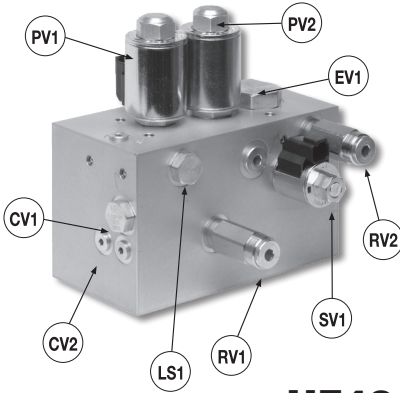

HF42407-07 PORTS

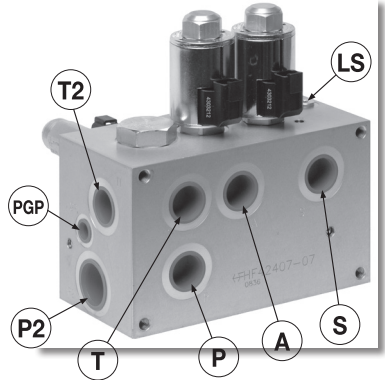

HF42407-07

DESIGNATION	DESCRIPTION	SIZE (SAE)
T	TANK	12
T2	TANK	12
P	PUMP	12
P2	PUMP	16
A	AUGER	12
S	SPINNER	12
LS	LOAD SENSE	4
PGP	PUMP GAGE PORT	6

ORIGINAL MESP-202H "LOAD SENSE" SCHEMATIC

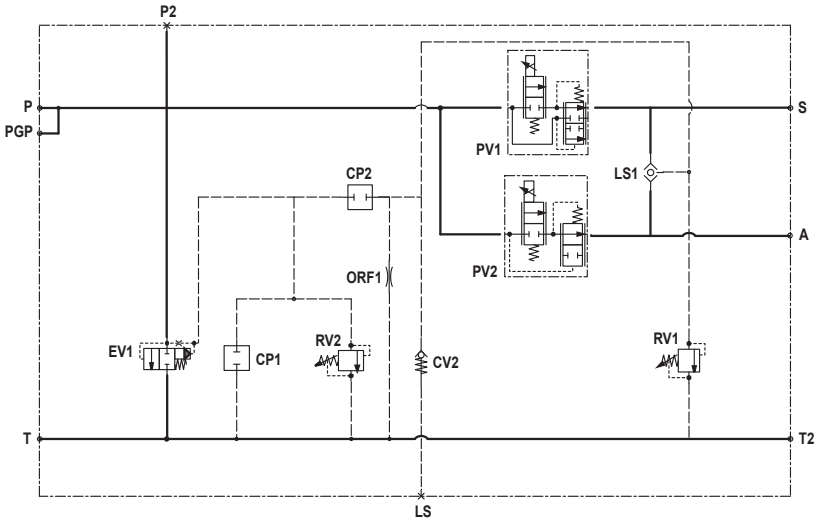

HF42407-07 VALVES

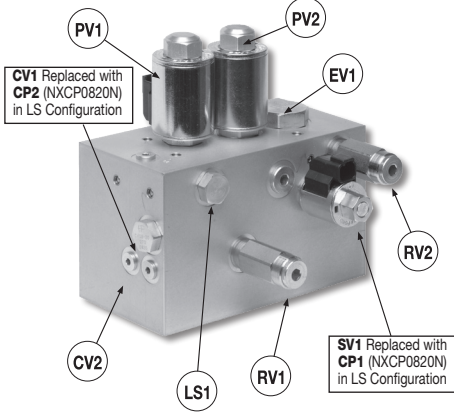

HF42407-07 PORTS

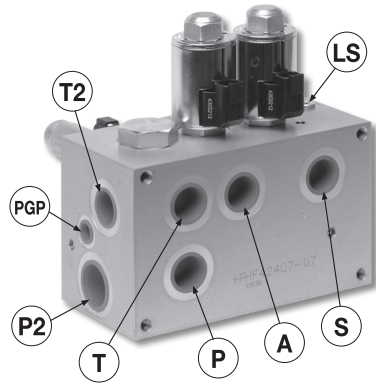

HF42407-07

DESIGNATION	DESCRIPTION	SIZE (SAE)
T	TANK	12
T2	TANK	12
P	PUMP	12
P2	PUMP	16
A	AUGER	12
S	SPINNER	12
LS	LOAD SENSE	4
PGP	PUMP GAGE PORT	6

REVISED MESP-202H MANIFOLD 4/1/09

CARTRIDGE DESIGNATIONS, FUNCTIONS, & PART NUMBERS

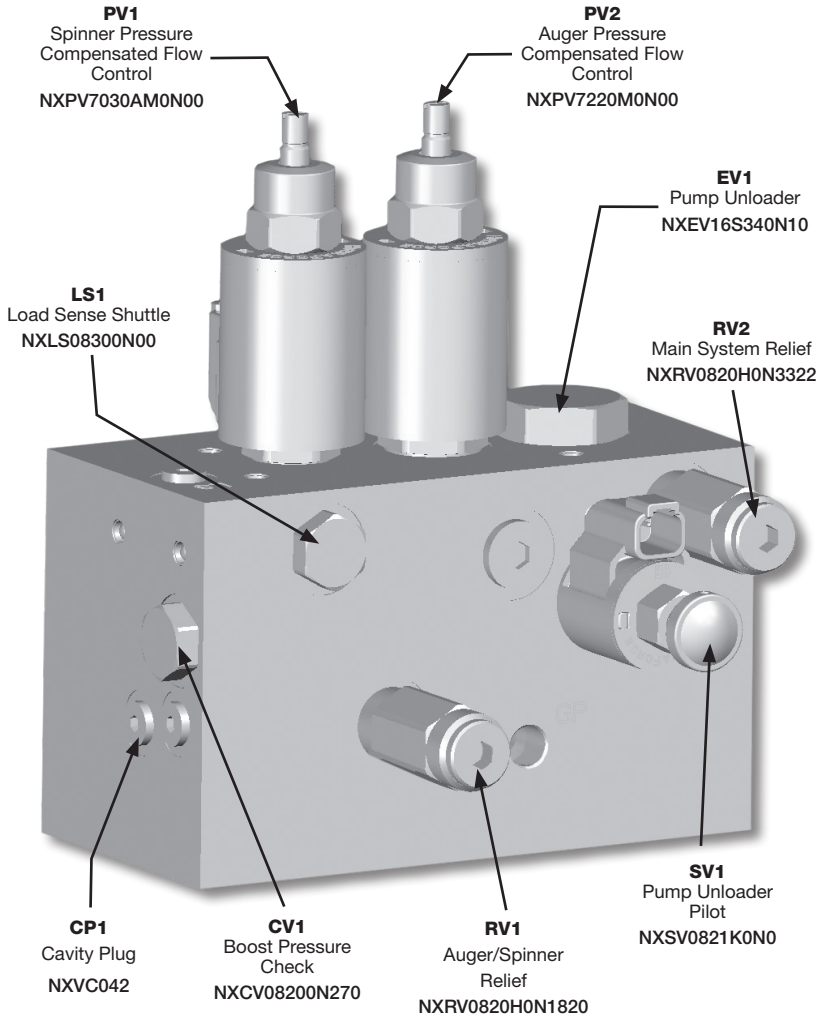

HF51912-09

COIL	PART NUMBERS
SV1	NX4303612
PV1	NX4303212
PV2	NX4303212

REVISED MESP-202H "OPEN CENTER" SCHEMATIC 4/1/09

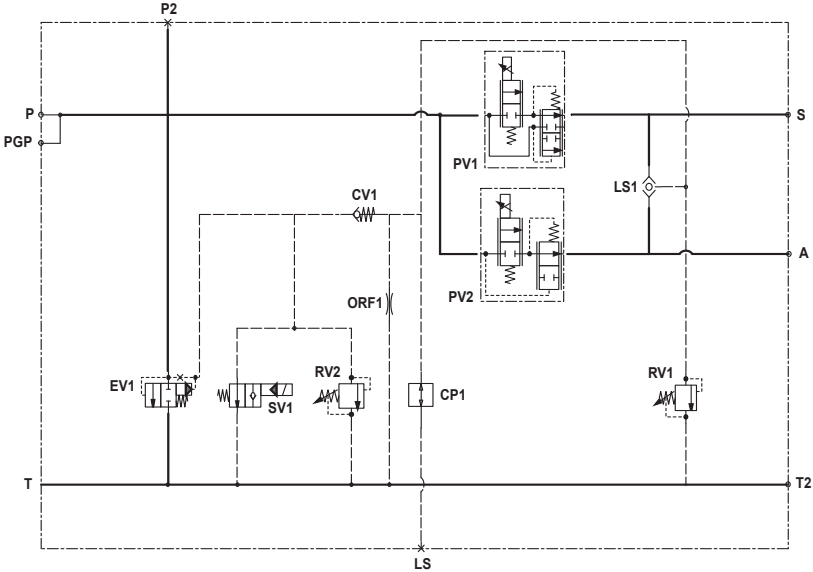

HF51912-09

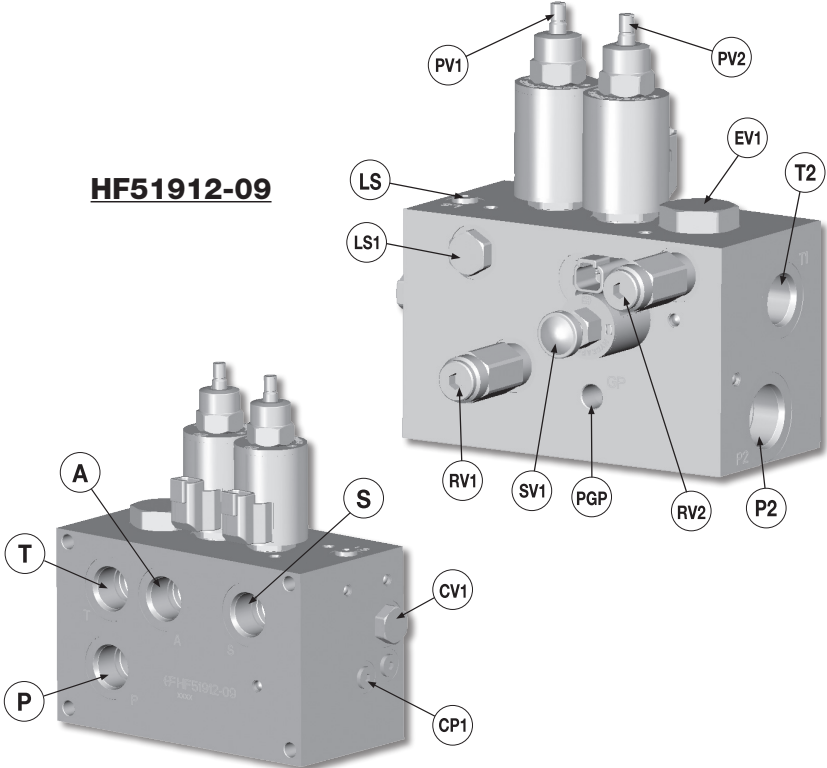

REVISED MESP-202H "LOAD SENSE" SCHEMATIC 4/1/09

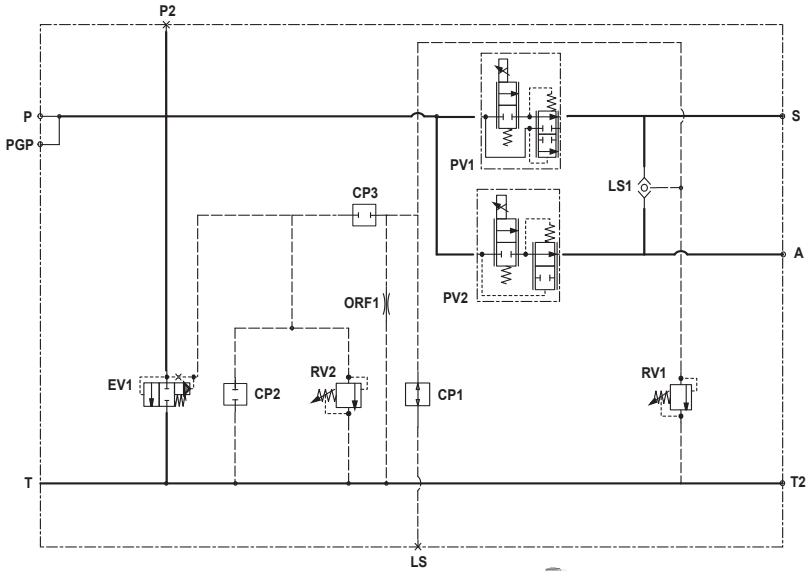

HF51912-09

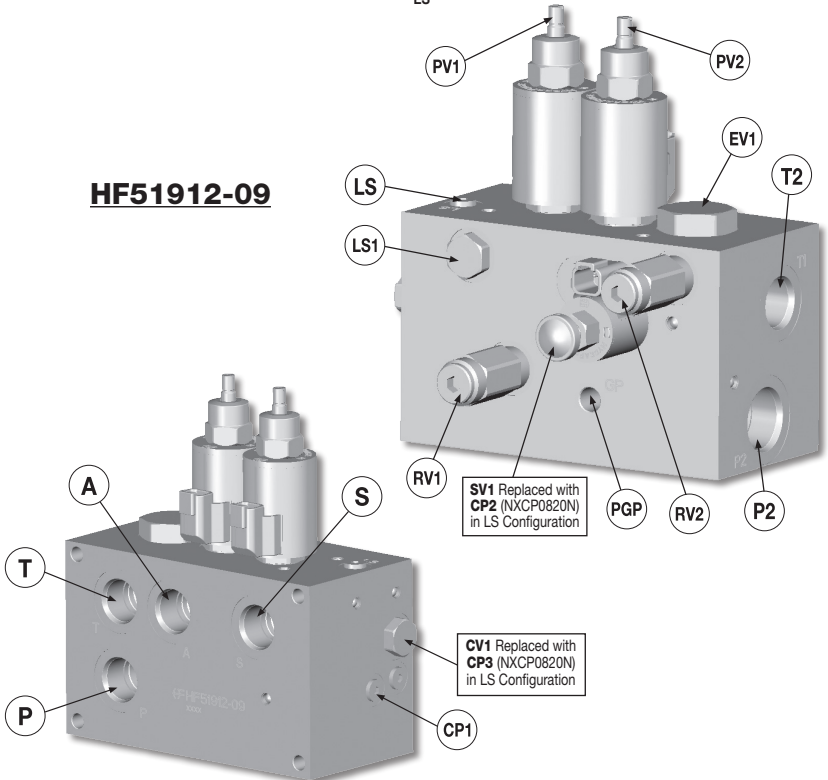

MESP-202H RELIEF VALVES

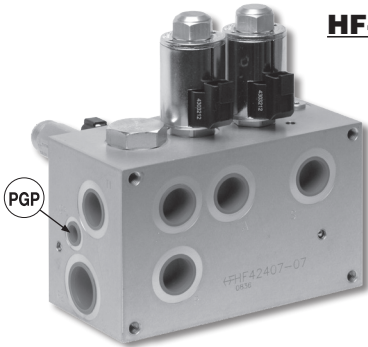

HF402407-07

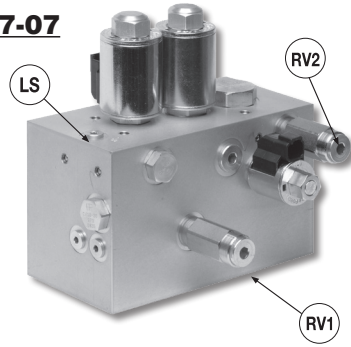

To Decrease the Pressure Settings

1. The tools required to adjust the relief valves include a $\frac{5}{16}$ " Allen drive and a $\frac{1}{4}$ " Allen drive.
2. Remove the caps from both of the relief valves. *Oil may seep out of these cartridges when the caps are removed and the system is operating.*
3. Place A gage in the PGP port. If not accessible, tee a gage in between the Pump Outlet and the Pressure Port (P) of the MESP202H.
4. Start the truck and Deadhead flow at either the Auger or Spinner.
5. Observe the gage in the L.S. port and adjust the auger/spinner relief CCW to the desired pressure.
6. Observe the Gage in the (PGP) port. Adjust the main relief CCW until it is approximately 200 P.S.I. higher than the L.S. gage.

HF51912-09

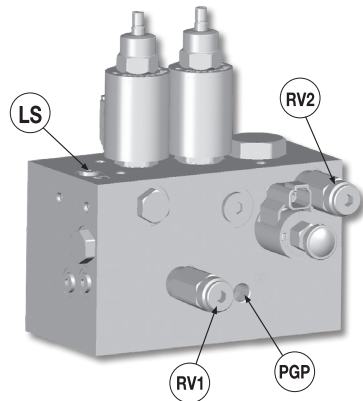

To Increase the Pressure Settings (3,000 P.S.I. Max.)

1. The tools required to adjust the relief valves include a $\frac{5}{16}$ " Allen drive and a $\frac{1}{4}$ " Allen drive.
2. Remove the caps from both of the relief valves. *Oil may seep out of these cartridges when the caps are removed and the system is operating.*
3. Place A gage in the PGP port. If not accessible, tee a gage in between the Pump Outlet and the Pressure Port (P) of the MESP202H.
4. Start the truck and Deadhead flow at either the Auger or Spinner
5. Both reliefs will need to be adjusted in small increments together.
6. Adjust the Auger/Spinner relief CW while observing both gages — stop turning when there is no change in the gage.
7. Adjust the main relief CW while observing both gages — stop turning when there is no change in the gage.
8. Repeat steps 5 and 6 until you arrive at desired P.S.I.
9. The main relief (PGP pressure) should have final setting about 200 P.S.I. higher than the spinner/auger relief (L.S. pressure).

DETAILED DESCRIPTION OF THE ORIGINAL AND REVISED MESP-202H

HF42407-07 AND HF51912-09

REFERENCE CIRCUIT SCHEMATIC FOR HF42407-07 OR HF51912-09

Pump Gage Port (PGP) – Indicates the inlet pressure from the pump. This pressure will be approximately 300 PSI higher than the actual pressure at the motors due to the load-sensing operation of the valve network.

Load Sense (LS) – Indicates the pressure of the load (motor). If more than one function is operating concurrently then the higher load pressure is seen. There will only be a pressure from the LS port if a function is operating. The LS port can be used to adjust the spinner/auger relief. Remember, the PGP will display a pressure approximately 300 PSI higher than the pressure in the LS port while a function is operating.

EV1 – Pump bypass and pre-pressure compensation cartridge. EV1 is a normally closed -two position - two way -pilot cartridge. It can provide a very low pressure path for pump flow to escape to tank. This is its primary function when no functions are operating. The bypass pressure of the pump in this state will vary from about 20-60 PSI depending upon the pump flow. This pressure will show at PGP. The path to tank is opened by pump pressure being applied to the left side pilot of EV1 which forces it open. The right side pilot line of EV1 is drained to tank through SV1 (Unloader Solenoid Valve) to allow this to happen.

Solenoid Valve (SV1) – Unloader solenoid valve. SV1 is a normally open- two position - two way solenoid operated cartridge. When its solenoid is not energized it provides a drain path for the pilot pressure on the right side of EV1. This allows for pilot pressure on the left side of EV1 to push it open and expose a low pressure path for the pump flow to escape to tank.

SV1 will energize whenever any function of the MESP 202H is operating. This closes the pilot drain on the right side of EV1 and that in-turn cause EV1 to begin shutting off the pump flow escape to tank. Pump flow is now forced to move toward motor valves as required. If SV1 was energized or manually overridden (if equipped) without any other system valves functioning, the pressure at PGP would be approximately 300 PSI. The L.S. port would not have pressure.

Check Valve (CV1) – Boost pressure check valve. CV1 is a simple spring biased ball check cartridge. Its purpose is to raise the differential or boost pressure between PGP and LS by a margin of approximately 300 PSI. It comes into play when SV1 is energized. At that point the pilot

pressure on the right side of EV1 can only drain through CV1. CV1's internal bias spring is set for 270 PSI. That means the pressure of EV1's pilots (both sides) must build to at least 270 PSI before the right side pilot can drain through CV1 and allow EV1 to begin to open. This boost pressure is required to allow flow to get through other cartridge valves in the system to operate functions.

When CV1 has a load-sense pressure applied to its right side which is communicated from LS1 (Load Shuttle) this will add to the pressure required for EV1 to drain its right side pilot and open. For example, if the load-sense pressure for a spreader motor is 1000 PSI, this will be added to the (270 PSI) spring bias pressure of CV1. Now EV1 cannot begin to open its path to tank until the pump pressure has achieved something slightly higher than 1,270 PSI. PGP would display 1,270 + PSI and L.S. port would display 1,000 PSI. In this way the system will always attempt to sustain a differential or boost pressure of approximately 300 PSI.

Relief Valve (RV2) – Main system relief valve. RV2 is an adjustable relief cartridge that is used in conjunction with EV1 to limit the maximum pump pressure. RV2 is located in the pilot path on the right side of EV1. It is preset from the factory at 2,200 PSI. This can be adjusted to a maximum of 3,000 PSI. When RV2 opens it begins to drain the pilot on the right side of EV1 at whatever pressure RV2 has been set. The pressure of the pump and the left side of EV1 will build slightly higher and force EV1 to begin to open and provide a tank path for the pump.

Orifice (ORF1) – Load sense drain orifice. ORF1 provides a controlled drain for the load-sense pilot line/EV1 control pilot. Its function is to ensure that the pressure cannot be trapped in this pilot and result in EV1 not being able to fully open at low pressure when required.

Check Valve (CV2) – (ONLY HF42407-07) Load-sense check valves. This check valve only allows flow to travel in one direction back to the pump.

Proportional Valve (PV1) – Spinner flow control valve. PV1 is a proportional solenoid flow control valve that also incorporates pressure compensation. In its unenergized state it provides a blocked path between the pump flow and the spinner work port. When it is energized it provides an increasing orifice opening to flow as a result of increasing electric current to its solenoid coil. Its range of flow control is 0-7 gallons-per-minute. A second internal stage of PV1 provides pressure compensation of the flow control. This stage will react to changes of pump pressure conditions relative to the spinner load pressure demands. If the pressure difference goes too high the compensator stage will "squeeze down" to prevent extra flow from "shooting" through the proportional valve orifice setting. The basis of stable flow control requires this feature.

Proportional Valve (PV2) – Auger/Conveyor flow control valve. PV2 is a proportional solenoid flow control valve that also incorporates pressure compensation. In its non-energized state it provides a blocked path

between the pump flow and the auger/conveyor work port. When it is energized it provides an increasing orifice opening to flow as a result of increasing electric current to its solenoid coil. Its range of flow control is 0-15 gallons-per-minute. A second internal stage of PV2 provides pressure compensation of the flow control. This stage will react to changes of pump pressure conditions relative to the auger/conveyor load pressure demands. If the pressure difference goes too high the compensator stage will “squeeze down” to prevent extra flow from “shooting” through the proportional valve orifice setting. The basis of stable flow control requires this feature.

Relief Valve (RV1) – Spreader pressure relief. RV1 limits the pressure of the spreader motor circuits. This gives independent protection to the motors from the rest of the system.

Load Sense (LS1) – Load shuttle cartridge. LS1 is similar to two check valves set back-to-back. Its purpose is to communicate the load pressure of the highest spreader motor pressure back to CV1.



**Muncie[®]
Power
Products**

A Member of the Interpump Group
IN09-05 (Rev. 02-18)

201 East Jackson Street • Muncie, Indiana 47305
800-367-7867 • Fax 765-284-6991
info@munciepower.com • www.munciepower.com
Specifications are subject to change without notice.
Visit www.munciepower.com for warranties and literature.
All rights reserved. © Muncie Power Products, Inc. (2009)