



ALTEC PTO

INSTALLATION INSTRUCTIONS



Supplement instructions; read Muncie PTO instructions found in IN84-03 installation and owner's manual completely before beginning work. Do not work on vehicle with hot exhaust, let cool several hours before beginning PTO installation. See additional WARNINGS inside front cover of installation manual IN84-03.

PTO INSTALLATION NOTES:

Vehicle without the "PTO Prep Package" will require deformation of the vehicle floor board directly above and rearward of the PTO opening or contact the dealer for a kit to alter your floorboard. Vehicles with the PTO package will find a bulge in the floor board; successful PTO installations have been made by uncovering the floor and removing this added in floor component. These instructions are listed for the typical under vehicle installation.

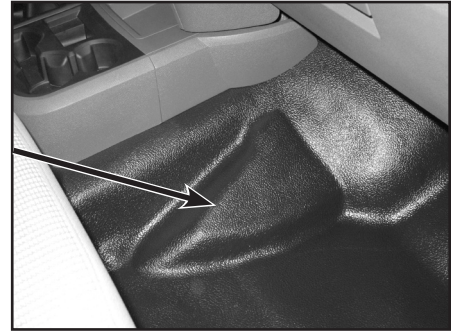

Factory deformation shown

1. Remove exhaust front down pipe attachments at turbo elbow & 3 bolt flange at particulate filter. The front end is held with a V-band clamp and the rear of the pipe is held with M10x1.5 nuts.
2. Disconnect exhaust isolator from hanger and allow rear part of exhaust system to hang down.



Bar welded to the exhaust pipe and pushed into rubber bushing

3. Push up on tunnel silencer at PTO floor patch.
4. Remove PTO cover from transmission.

5. Remove plugs on transmission from the "main pressure" port and Lubrication port as shown.

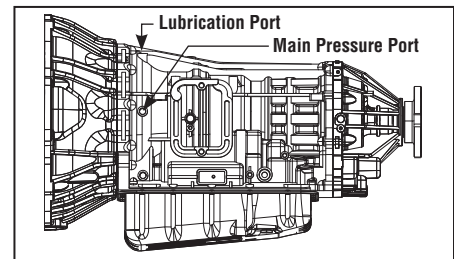

6. Un-plug temp switch from cooler line. Remove electrical connector from pressure switch on transmission these are located near the PTO opening and can be in the way during PTO installation.

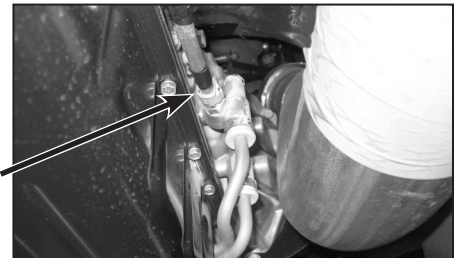



ALTEC PTO INSTALLATION INSTRUCTIONS

PTO INSTALLATION

7. Install PTO mounting studs as described in PTO installation and owner's manual IN84-03.
8. Install gasket/shim onto studs.
9. Install orifice fitting and lube line to PTO.
10. Install activation pressure and exhaust lines to PTO.
11. Lift and slide PTO to transmission opening and mount on studs.
12. Install nuts to studs & torque (see IN84-03) Use caution when installing the stud for the Aisin transmission. The studs provided are a special length and inserting them too far may cause damage to the transmission or limit the thread engagement of the mounting nuts.
13. Locate and install the Muncie solenoid shift valve.
14. Install the hydraulic activation lines as shown in diagram B.
15. Install a Muncie PF or PK series pump.
16. For PTO to operate properly and utilize the Dodge speed control, the vehicle computer must be programmed for PTO mode. Contact Dealer if this is necessary.

17. The PTO is supplied with a special wire harness for connection to the PTO solenoid valve and the PTO pressure switch. The orange wire is to be connected to the PTO activation control by Altec. the black wire is a ground. The pressure switch is a green wire which connects to the PTO indicator and the black wire is a ground connection.

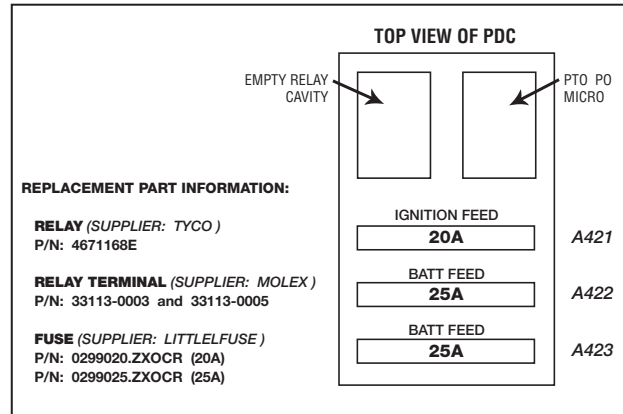

Located in the vehicle glovebox are a relay, fuses and a wireharness. For PTO operation, the vehicle must have the relay and fuse installed in the Power Distribution Box located under the hood. The 20A fuse is used by the PTO. The 25A locations are for other Body Builder connections.



ALTEC PTO INSTALLATION INSTRUCTIONS

DIAGRAM A:

Wiring - 34T41356 Wire Harness

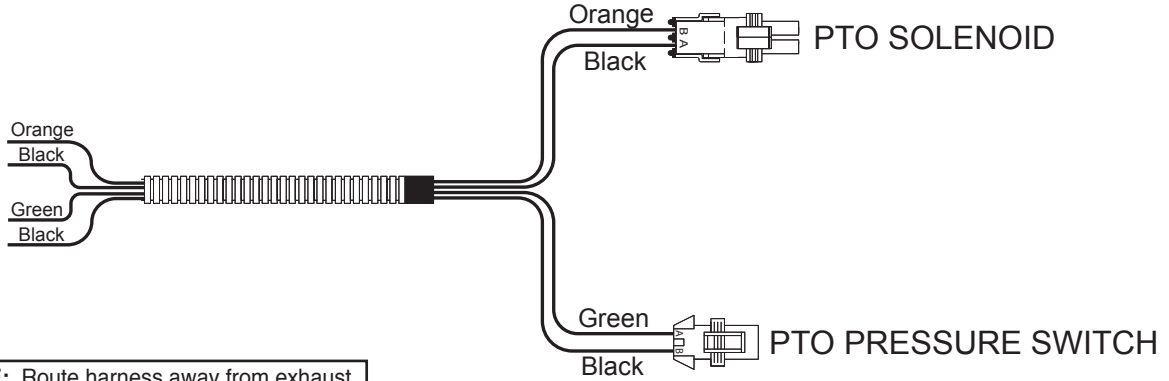

NOTE: Route harness away from exhaust and rotating components.

DIAGRAM B:

48TK5082 Dodge Activation Kit Automatic

48TK5082 INSTALLATION KIT

ITEM	QTY	PART NO.	DESCRIPTION
1	1	43T37557	Adapter
2	2	43T35867	Elbow Fitting
3	1	45T36274	Hose Assembly
4	1	35T37928	Solenoid
5	3	43M68014	JIC Fitting
6	2	43T38840	Hose 36"
7	1	43T37503	JIC Fitting
8	1	30T37954	Pressure Switch

** Components supplied with pressure lubrication option (43TK3934) and "P" option PTO.

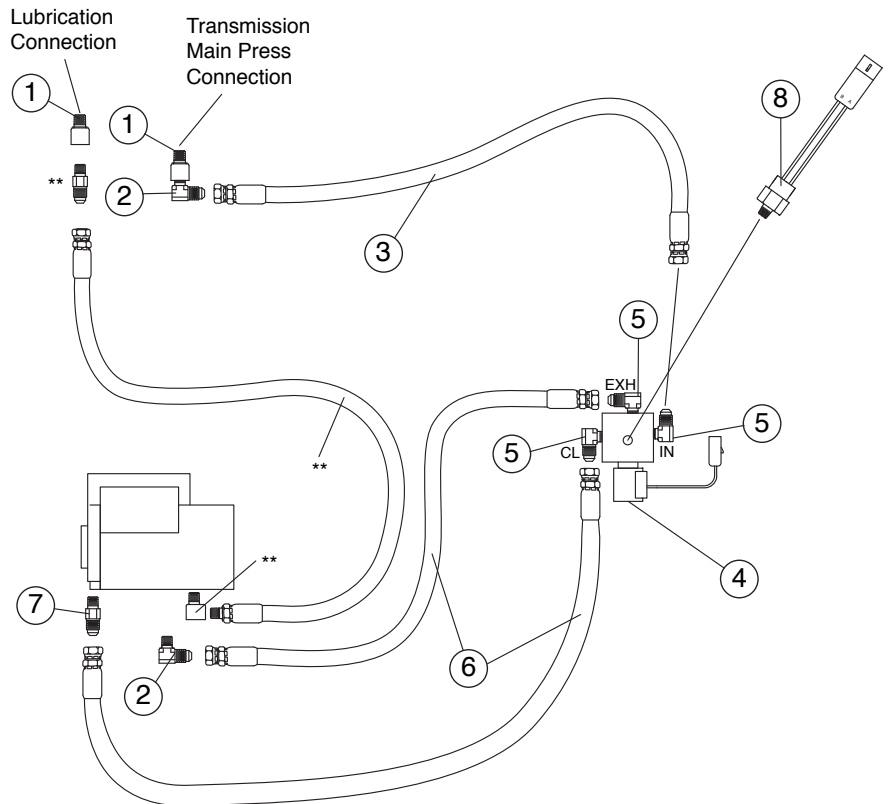

NOTE: Route harness away from exhaust and rotating components.



ALTEC PTO INSTALLATION INSTRUCTIONS

18. Re-attach the exhaust, DPF tubing, transmission pressure switch, and temperature switch connectors that were removed earlier.

19. The exhaust V-band clamp is tightened to a torque value of 150 in. lb. and the M10 nuts at rear of pipe are torqued to 43 ft. lb.

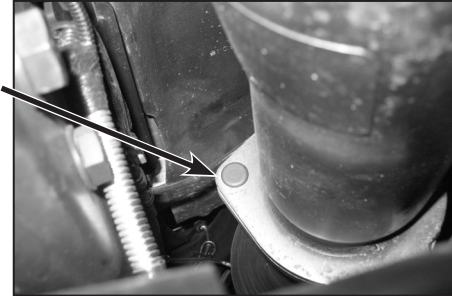

20. Return to the PTO Installation and Owner's Manual, IN84-03, and finish installation.



IN09-17 Printed in the U.S.A.
© Muncie Power Products, Inc. 2009

Muncie Power Products, Inc. Member of the Interpump Hydraulics Group
General Offices and Distribution Center • P.O. Box 548 • Muncie, IN 47308-0548
(765) 284-7721 • FAX (765) 284-6991 • E-mail info@munciepower.com
Web site <http://www.munciepower.com>

Drive Products, Exclusive Agents for Canada, ISO Certified by an Accredited Registrar