



Muncie[®]
Power
Products

SS66/SS88

Split Shaft PTO

Installation Instructions



Model Number Construction

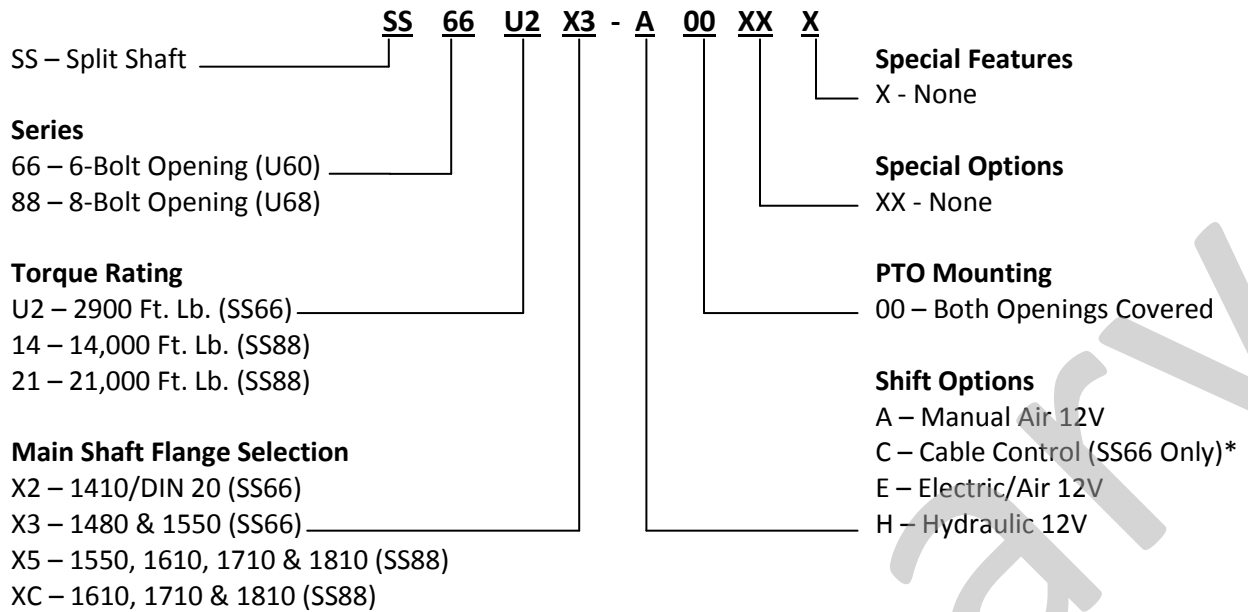

*Order control cable separately; 55 series with 2" travel and bulkhead mount.
Example: KB55-BM-2-XXX where XXX denotes length in inches.

Application Information

Throughput Torque:

- U2 – 2,900 Ft. Lb./400 Kg. M. (SS66)
- 14 – 14,000 Ft. Lb./2,000 Kg. M. (SS88)
- 21 – 21,000 Ft. Lb./3,000 Kg. M. (SS88)

Calculating Throughput Torque: Multiply Max engine torque by the deepest transmission ratio.

- Example: Ford Super Duty F-450
- Engine = 7.3L Diesel Engine 235HP @ 2600 RPM 500 Ft.Lb. @ 1800 RPM
- Transmission = ZF S6-650 6 Speed OD

1 st	2 nd	3 rd	4 th	5 th	6 th	Rev
5.79	3.31	2.10	1.31	1.00	0.72	5.23

Through Torque = 500 Ft.Lb. X 5.79 Ratio = 2,895 Ft.Lb.

Maximum PTO Torque:

- The SS66 PTO drive gear has a maximum rated torque of 289 Ft.Lb.
- The SS88 PTO drive gear has a maximum rated torque of 1200 Ft. Lb.

Note: PTO input gear loads must NOT exceed this value regardless of the number of PTOs used. PTO applications are limited to intermittent application only.

Split-Shaft Installation

SS66/SS88 Split-Shaft Positioning

The Muncie split-shaft unit should be located between the transmission and the rear axle, as close as possible to the transmission output flange; if possible, locate the split-shaft unit in place of the midship bearing. Elastic suspension elements are recommended and are to be fitted between the split-shaft and the truck chassis.

Note: The SS66/SS88 split-shaft is not available with a driveline brake. Vehicles with a driveline brake (parking brake) attached to the rear of the transmission will need to have this brake moved to the rear of the split-shaft or have the parking brake installed for use with stationary PTO applications.

Mounting the SS66/SS88 Split-Shaft Unit

- Welding to the frame or cross members is **NOT** allowed.
- All brackets should be fastened to the truck frame using bolts.
- Existing holes should be used.
- Additional holes should only be made with the approval of the truck manufacturer.
- Mounting components are not provided with this unit and are the responsibility of the installer.
- Unit is to be mounted with the breather located upright as shown in the diagram below.
- PTO(s) should be mounted with the shaft arrangement low as shown.

SS66 Mounted with Support Bracket

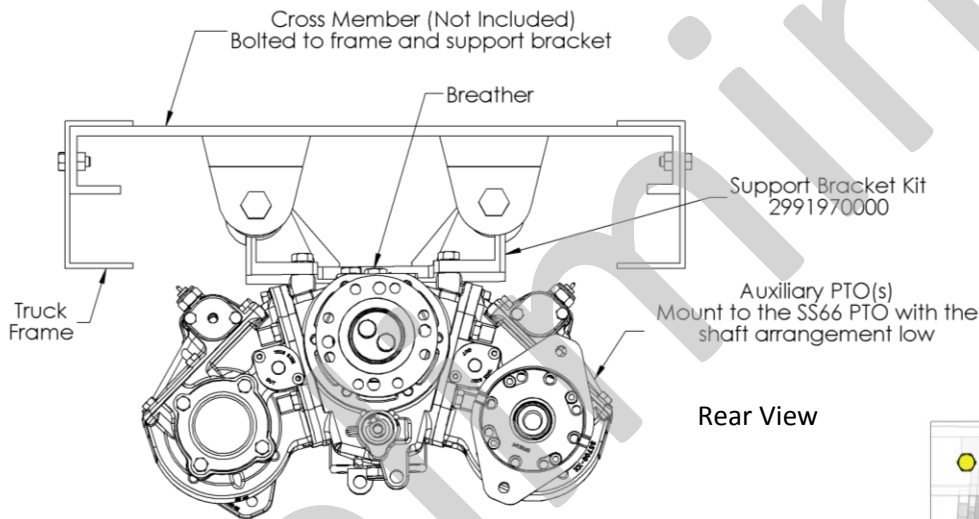

SS88 Mounted with Support Bracket

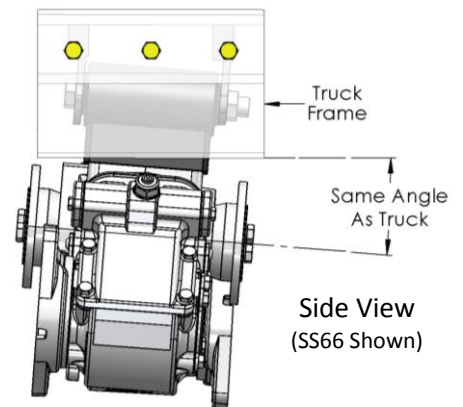
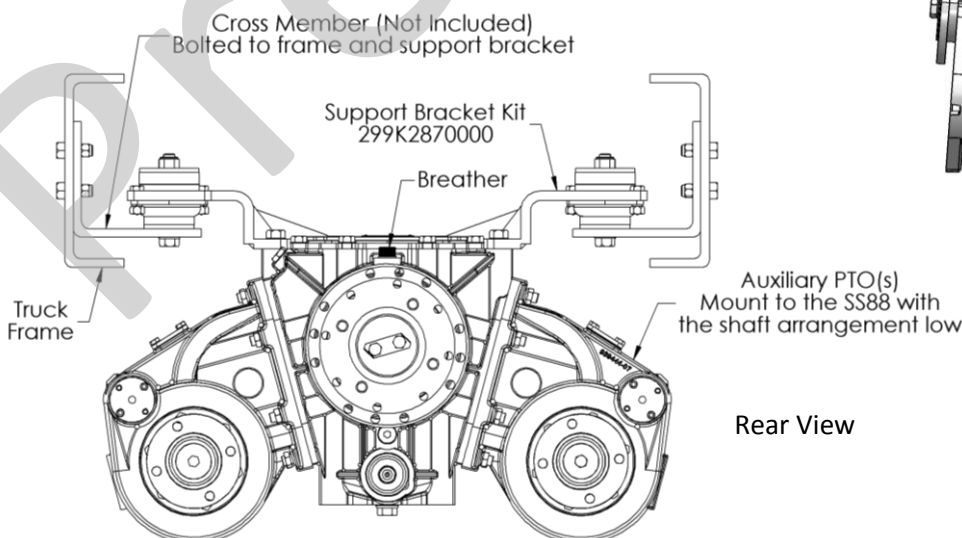

Drive Shafts

Contact your local Driveline shop for driveshaft's and driveshaft alterations.

All shafts used in the vehicle's driveline should be the same size and quality as the original ones. The same applies to flanges, bolts and nuts. Self-locking nuts should never be used twice and should be replaced by new ones.

- **Balance** – All driveshafts should be statically and dynamically balanced.
- **Angles** – To prevent vibration and noise during operation, all drive flanges must be parallel. Therefore, it is necessary to incline the split-shaft unit and all other driven equipment at the same angle to the truck frame as the transmission. This angle varies with the truck model. Information should be obtained from the truck manufacturer.
- **Phase** – Drivelines with slip joints should be used. Make sure enough compensation is allowed for length changes. When assembling, make sure all U-joints are correctly phased by ensuring that index markings are correctly aligned.
- **Protection** – For safety reasons, it is highly recommended to provide all accessible drivelines with protection covers.

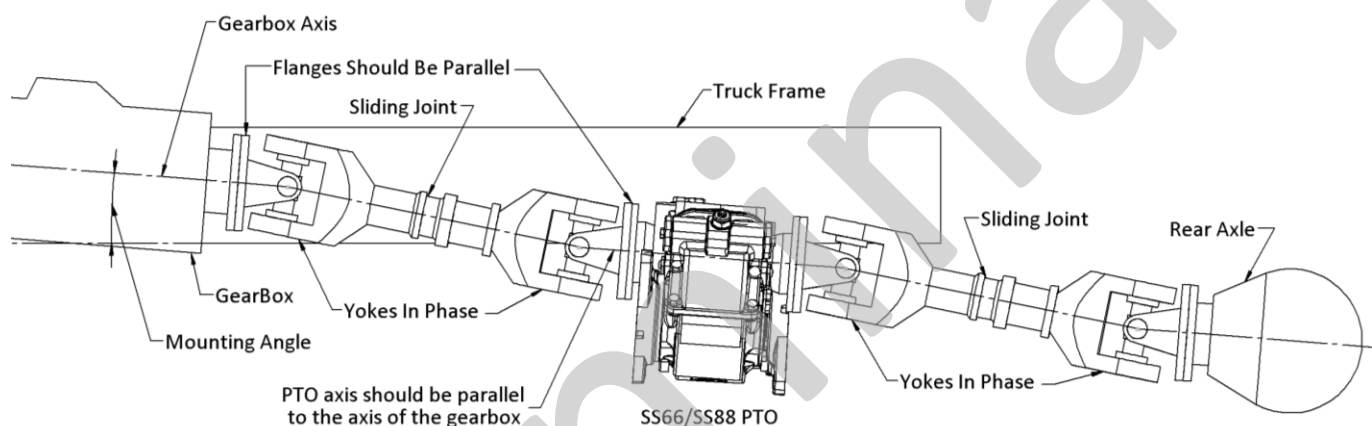

Oil Level

- The Split-shaft must be filled with oil up to fill level plug before use.
- Remove fill plug and fill unit to this level with SAE 90 EP gearbox oil.
- Replace plug.
- Check oil level regularly every 2 weeks.

Dimensional Information

SS66 PTO

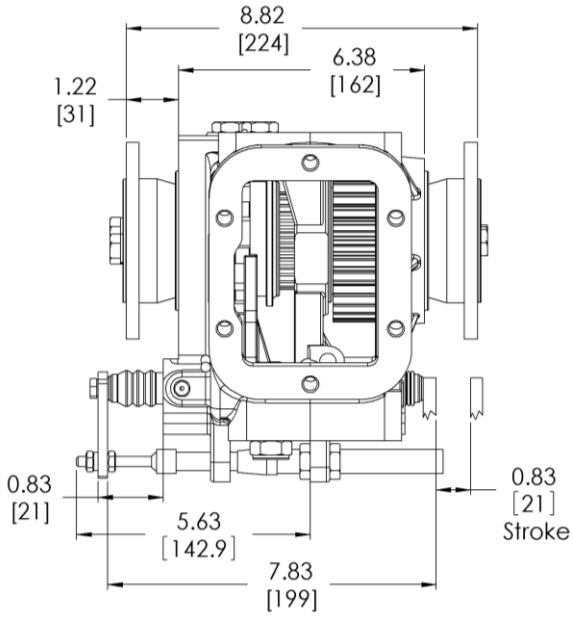

Side View

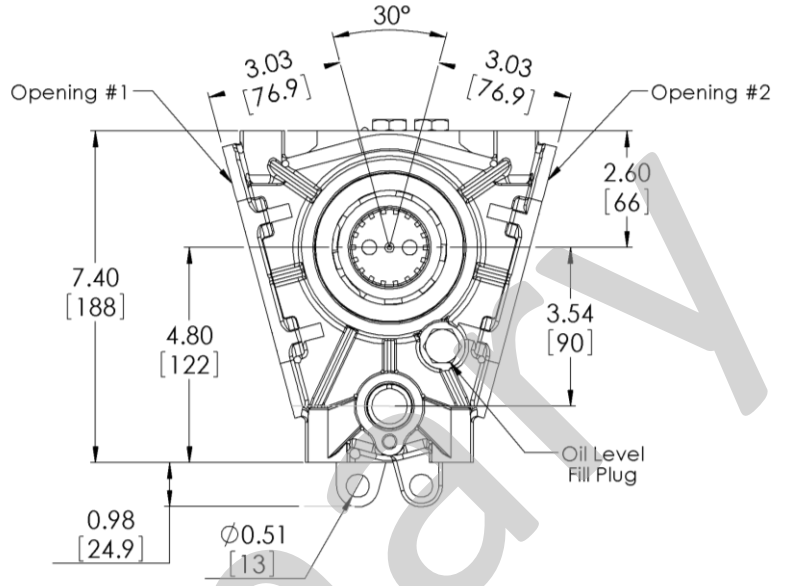

Front View

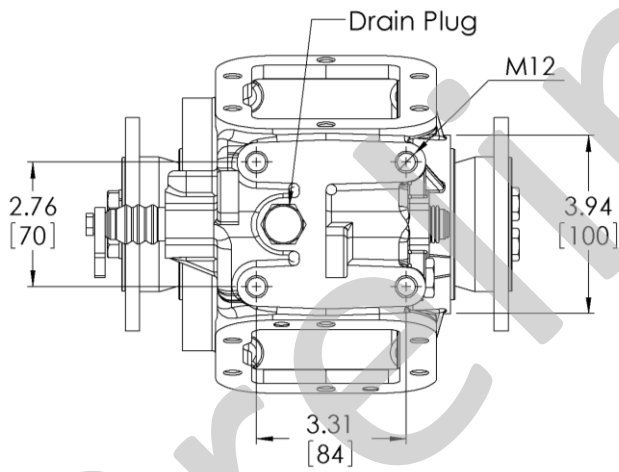

Bottom View

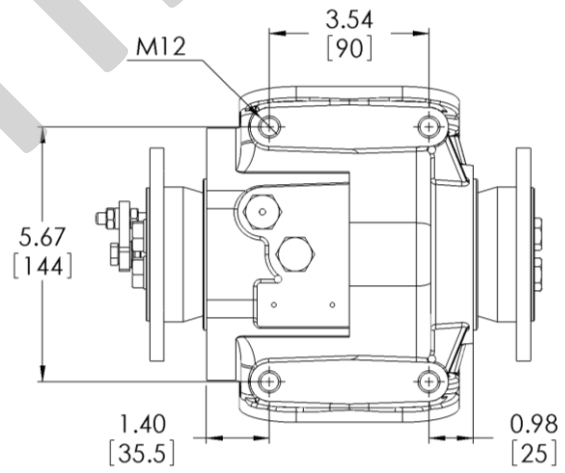

Top View

Front of Vehicle
→

SS88 PTO

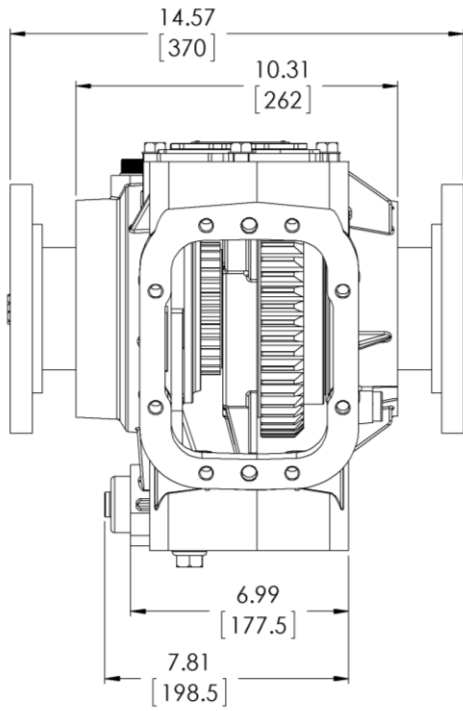

Side View

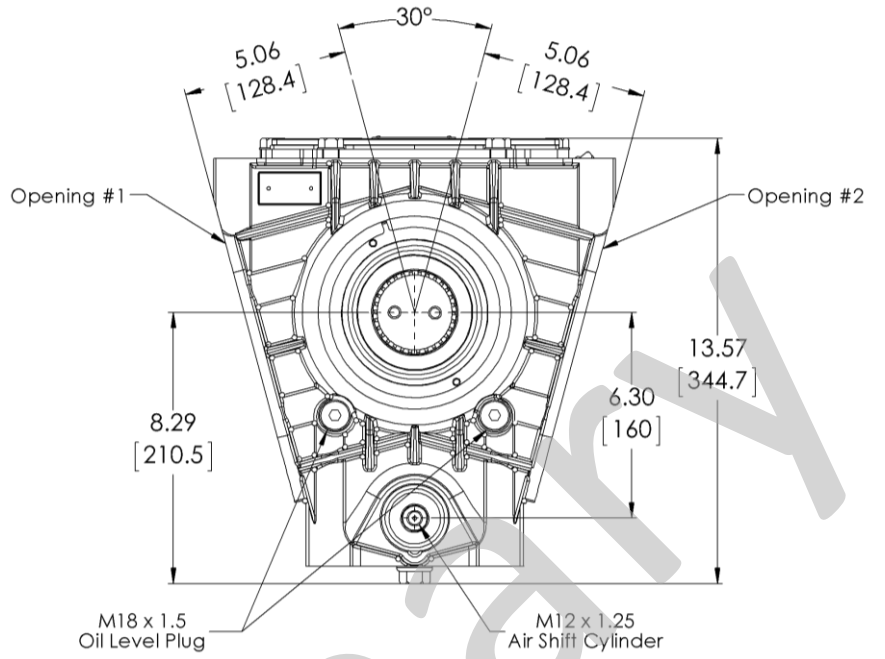

Front View

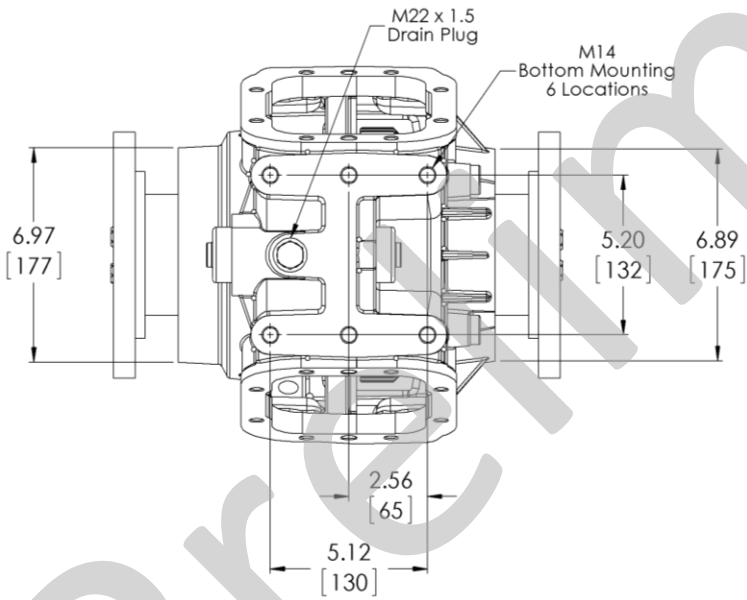

Bottom View

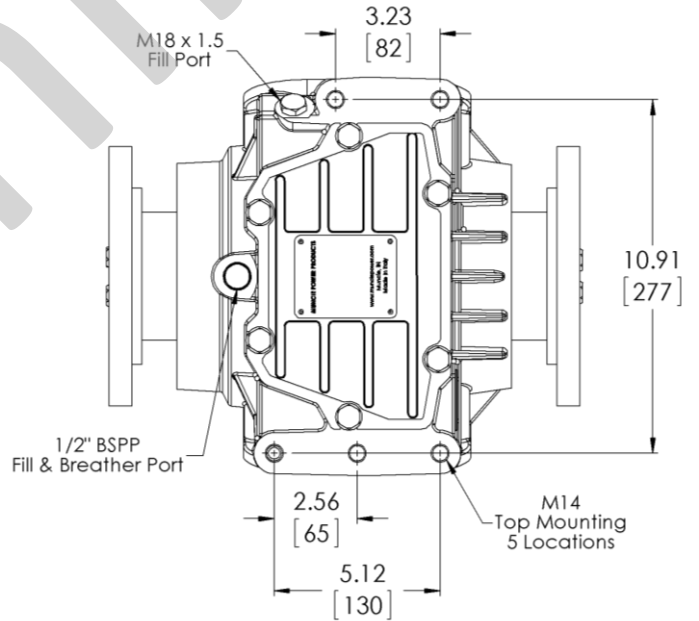

Top View

Front of Vehicle

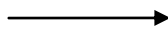

Main Shaft Flanges

SS66 PTO

1410/DIN 20 Flange

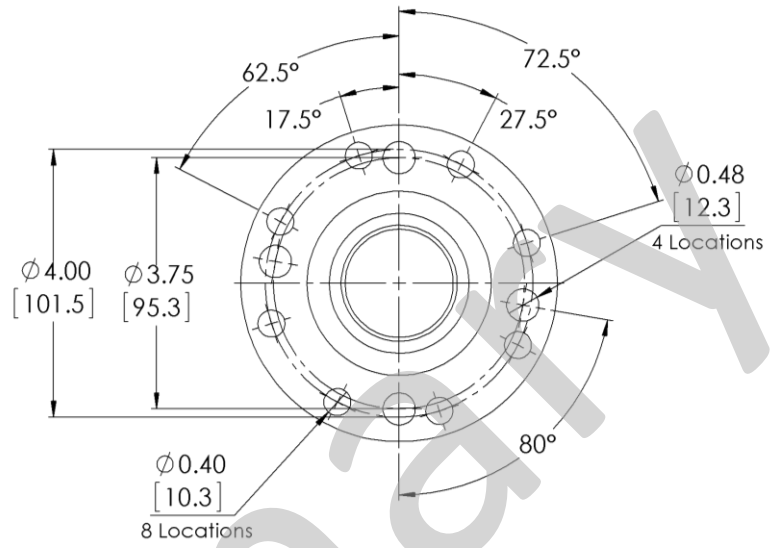
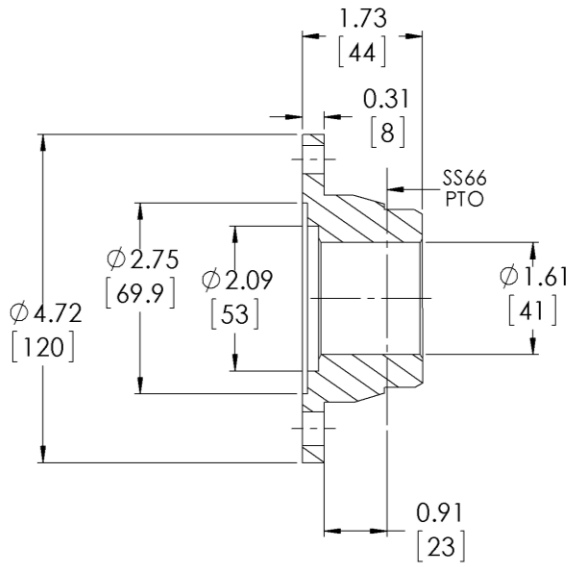

1480/1550 Flange

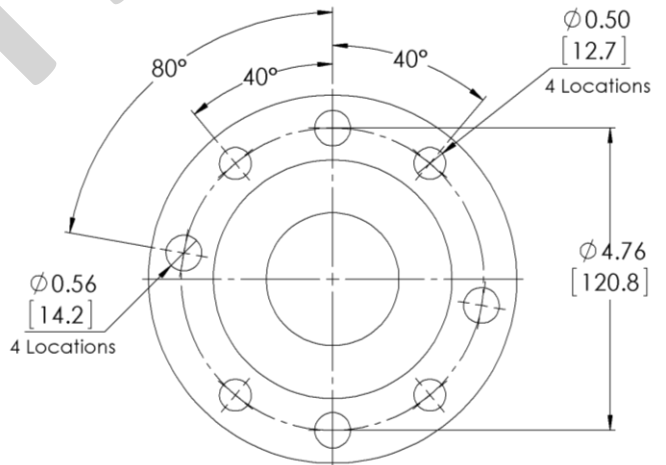
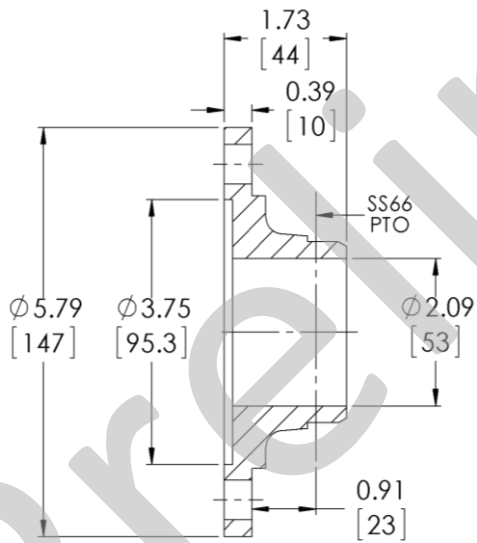

SS88 PTO

14 – Main Shaft Flange 1550/1610/1710/1810

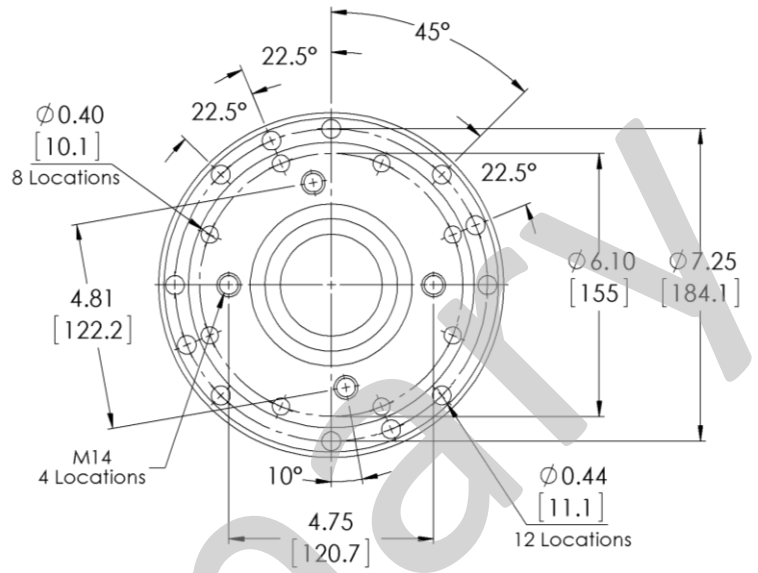
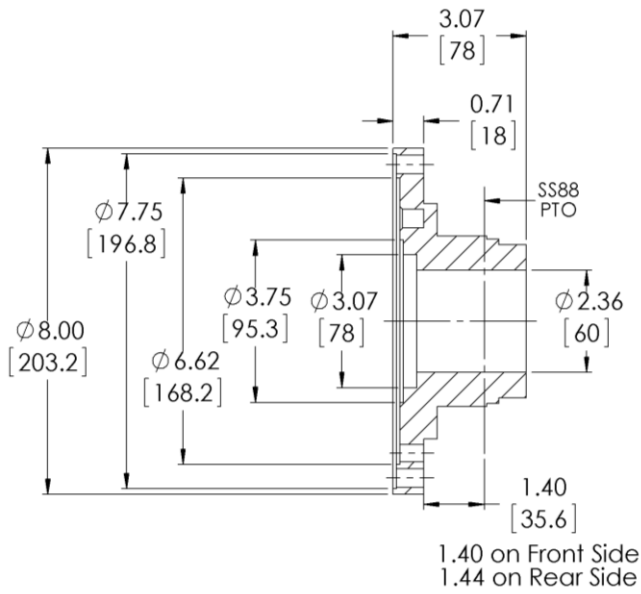

21 – Main Shaft Flange 1610/1710/1810

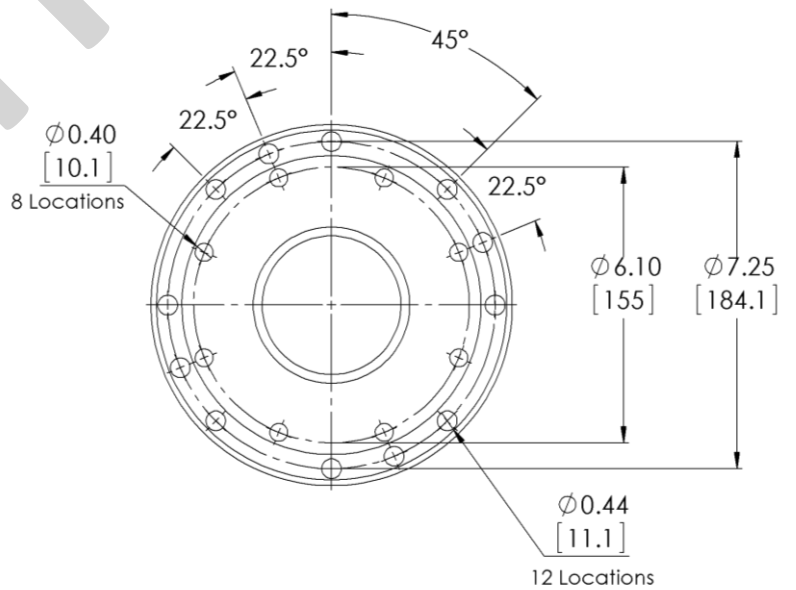
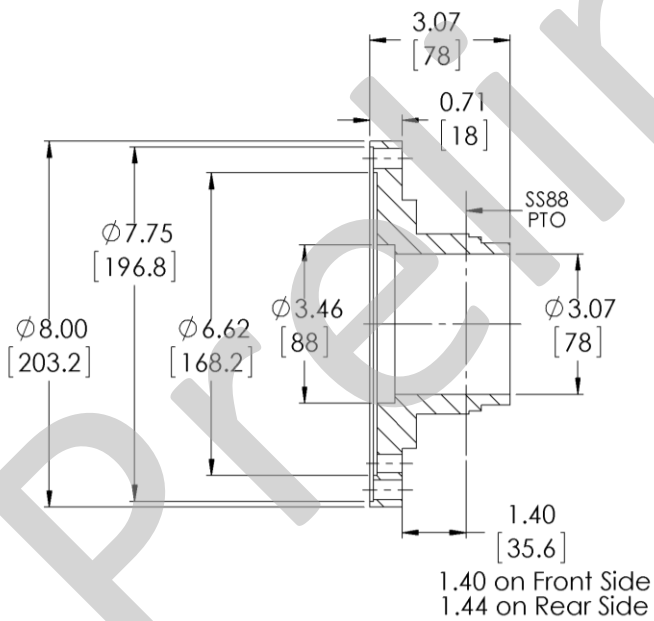

SS66 Support Bracket Kit – 2991970000*

Front View

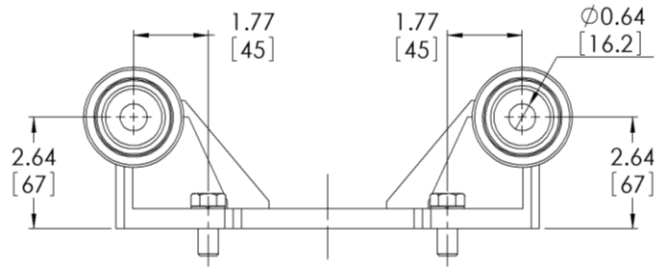

Top View

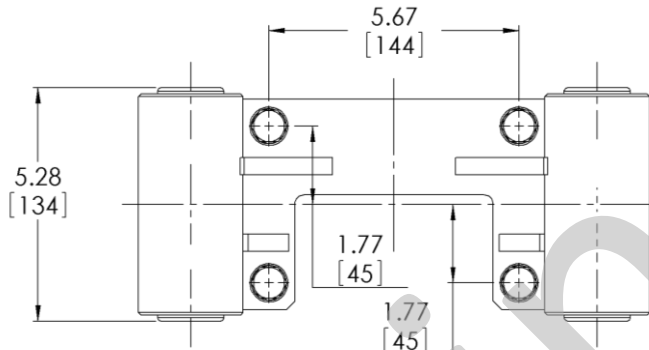

SS88 Support Bracket Kit – 299K2870000*

Front View

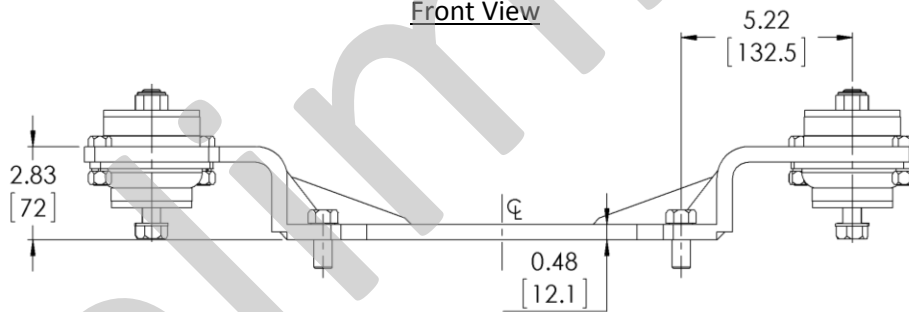

Top View

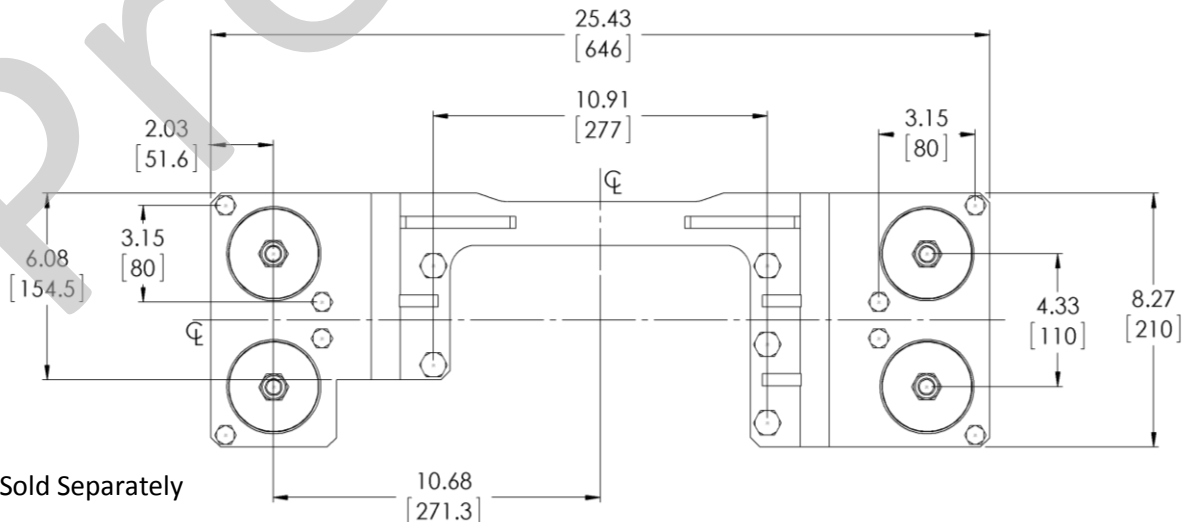

*Kit Sold Separately

SS66/SS88 Activation Kits

SS66 Manual Air: A-Option – 48TK4985

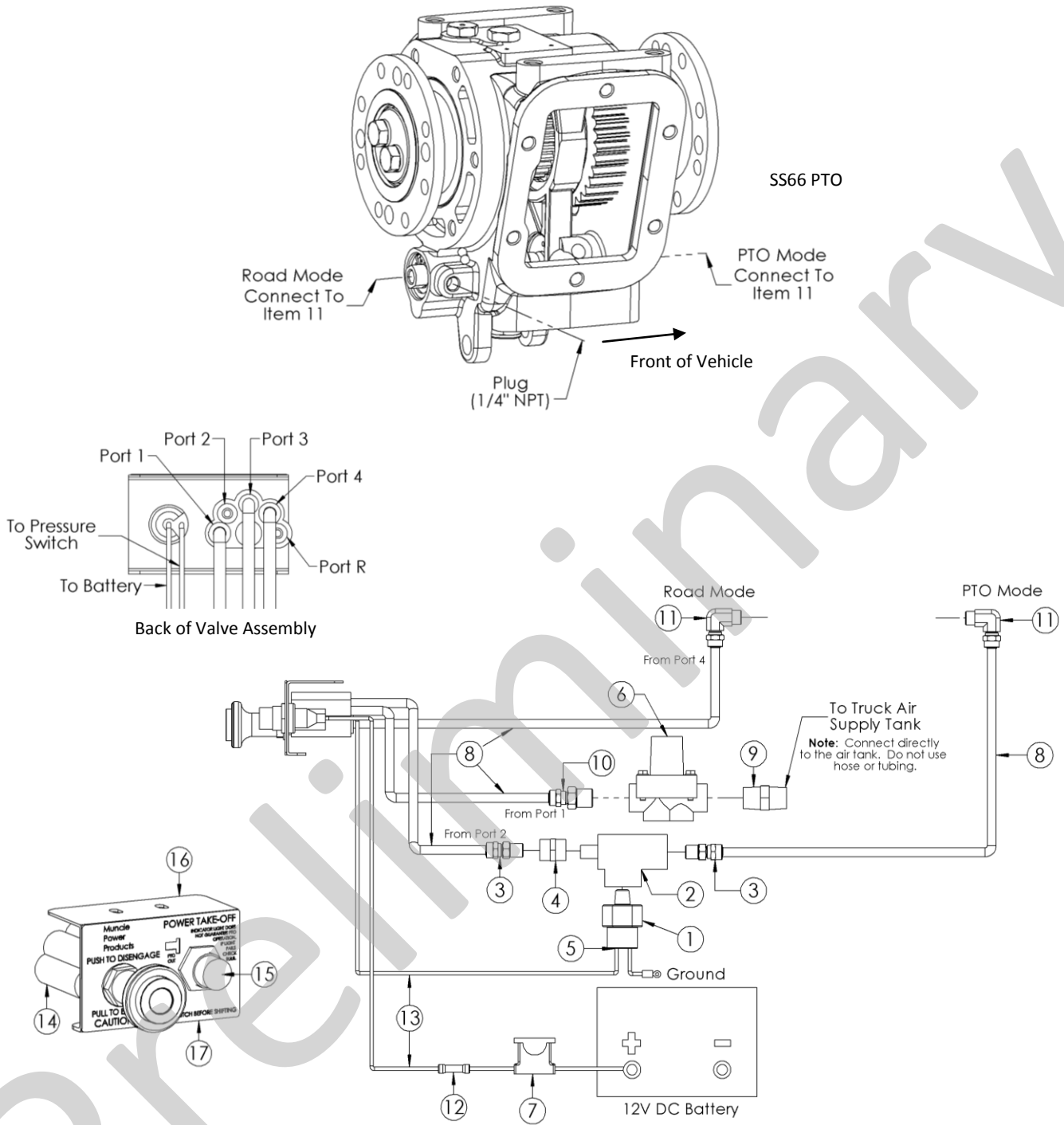

ITEM	QTY	PART NO	DESCRIPTION
Activation Kit 48TK4985			
1	1	30T37954	Pressure Switch
2	1	44MB2252	1/8" NPT Street Tee
3	2	44MB6842	1/8" NPT Fitting
4	1	44T35791	Fitting
5	1	34T36941	Pig Tail
Activation Kit 48M61261A (Included in 48TK4985)			
6	1	31M15759	Pressure Protection Valve
7	1	33T36299	Fuse Assembly
8	1	45M44430	Air Tubing 30 Ft.
9	1	44MB2164	1/4" NPT Nipple

ITEM	QTY	PART NO	DESCRIPTION
10	1	44MB6844	1/4" NPT Fitting
11	2	44MB6942	Elbow Fitting
12	3	34M18002	End Crimp
13	12.5 Ft.	37M18000	Electrical Wire
14	1	35T37955	Air Valve
15	1	32M12001	PTO Light - 12v DC
16	1	36T38049	Dash Bracket
17	1	36T38016	Face Plate
N.S.	1	34T38163	Booted Connector
N.S.	1	36MK1007	Bolt Kit

SS88 Manual Air: A-Option – 48TK4428

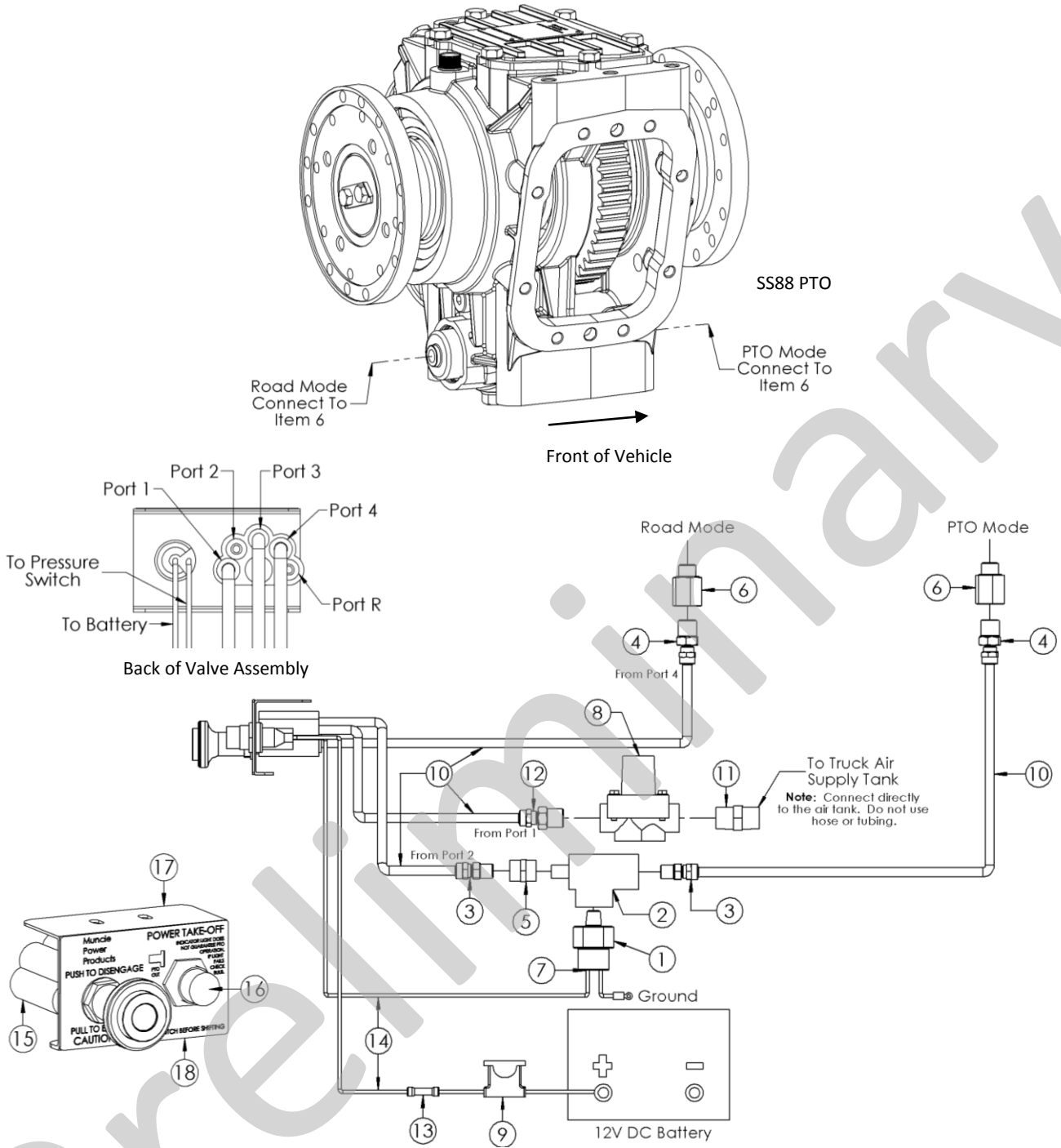

ITEM	QTY	PART NO	DESCRIPTION
Activation Kit 48TK4428			
1	1	30T37954	Pressure Switch
2	1	44MB2252	1/8" NPT Street Tee
3	2	44MB6842	1/8" NPT Fitting
4	2	44MB6844	Fitting
5	1	44T35791	Pipe Coupling
6	2	44T38628	12mm x 1/4 NPT Adapter
7	1	34T36941	Pig Tail
Activation Kit 48M61261A (Included in 48TK4428)			
8	1	31M15759	Pressure Protection Valve
9	1	33T36299	Fuse Assembly

ITEM	QTY	PART NO	DESCRIPTION
10	1	45M44430	Air Tubing 30 Ft.
11	1	44MB2164	1/4" NPT Nipple
12	1	44MB6844	Fitting
13	3	34M18002	End Crimp
14	12.5 Ft.	37M18000	Electrical Wire
15	1	35T37955	Air Valve
16	1	32M12001	PTO Light - 12v DC
17	1	36T38049	Dash Bracket
18	1	36T38016	Face Plate
N.S.	1	34T38163	Booted Connector
N.S.	1	36MK1007	Bolt Kit

SS66 Manual Air: E-Option – 48TK5248

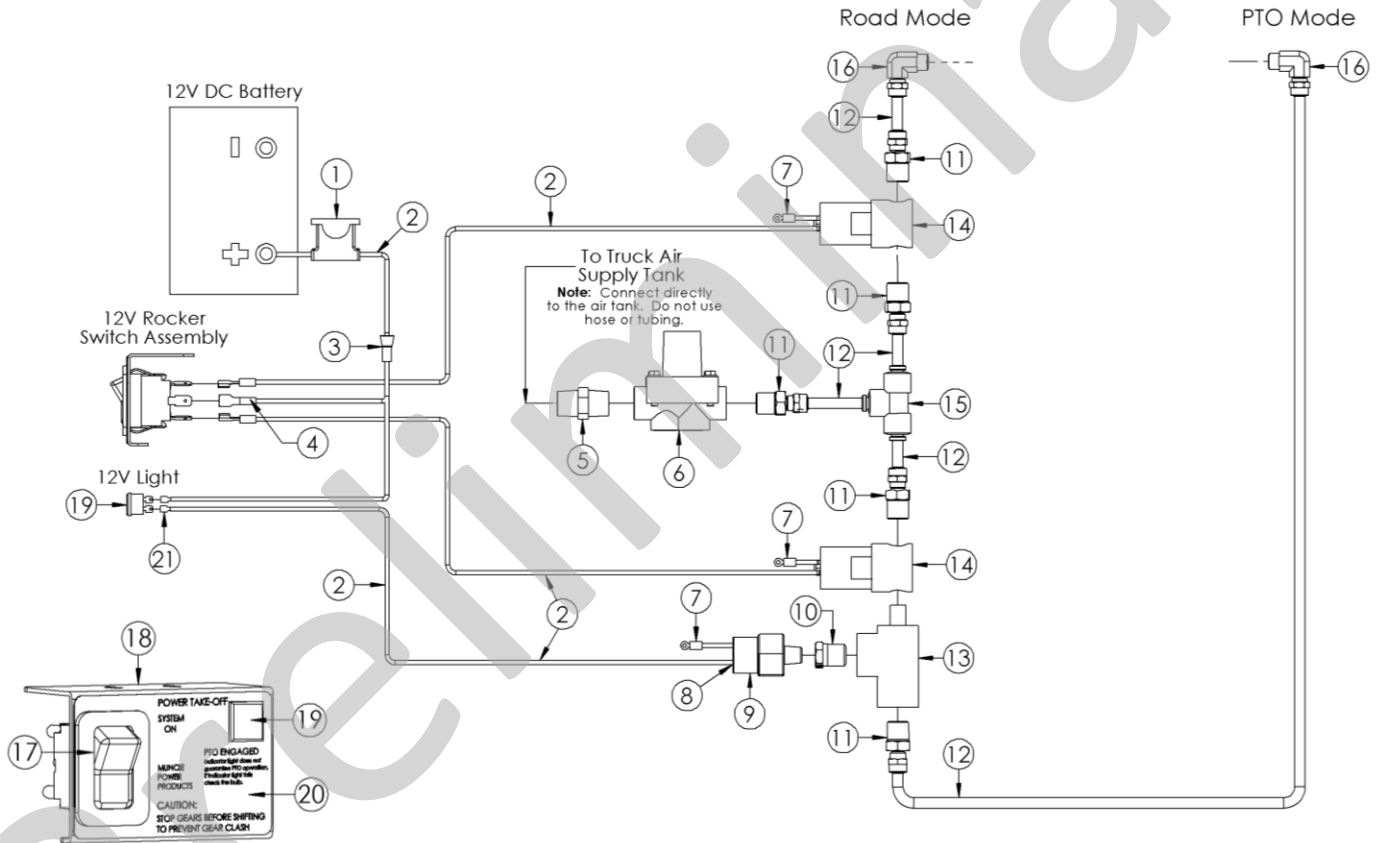
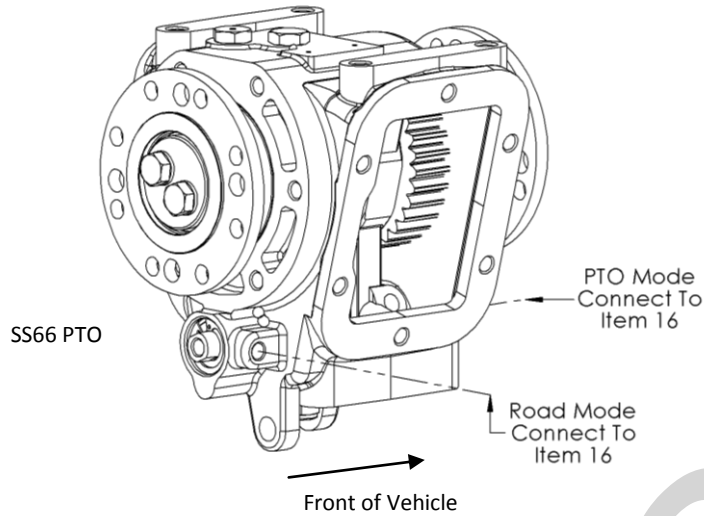

ITEM	QTY	PART NO	DESCRIPTION
1	1	33T36299	Fuse Assembly
2	12 Ft.	37M18000	18 Ga. Red Wire
3	6	34T36362	Crimp Connector
4	3	34M18250	Female Spade Connector (1/4")
5	1	44MB2164	1/4" NPT Nipple
6	1	31M15759	Pressure Protection Valve
7	3	34M18009	Ring Terminal
8	1	34T36941	Harness Pigtail
9	1	30T37954	Pressure Switch
10	1	44MB0942	Reducer Bushing
11	5	44MB6844PTC	Push To Connect Tube Fitting

ITEM	QTY	PART NO	DESCRIPTION
12	1	45M44430	Air Tubing 30 Ft.
13	1	44MB2254	1/4" NPT Street Tee
14	2	35M30692	12V Solenoid NC
15	1	44T40394	1/4" Tee Fitting
16	2	44MB6942PTC	Push To Connect Elbow Fitting
17	1	30T41994	12V Rocker Switch
18	1	36MA1005	Dash Bracket
19	1	32MSR12V	12V Light
20	1	36T35431	Face Plate
21	2	34M18187	Female Spade Connector (3/16")
22	N.S.	36MK1007	Bolt Kit

SS88 Manual Air: E-Option – 48TK5268

SS88 PTO

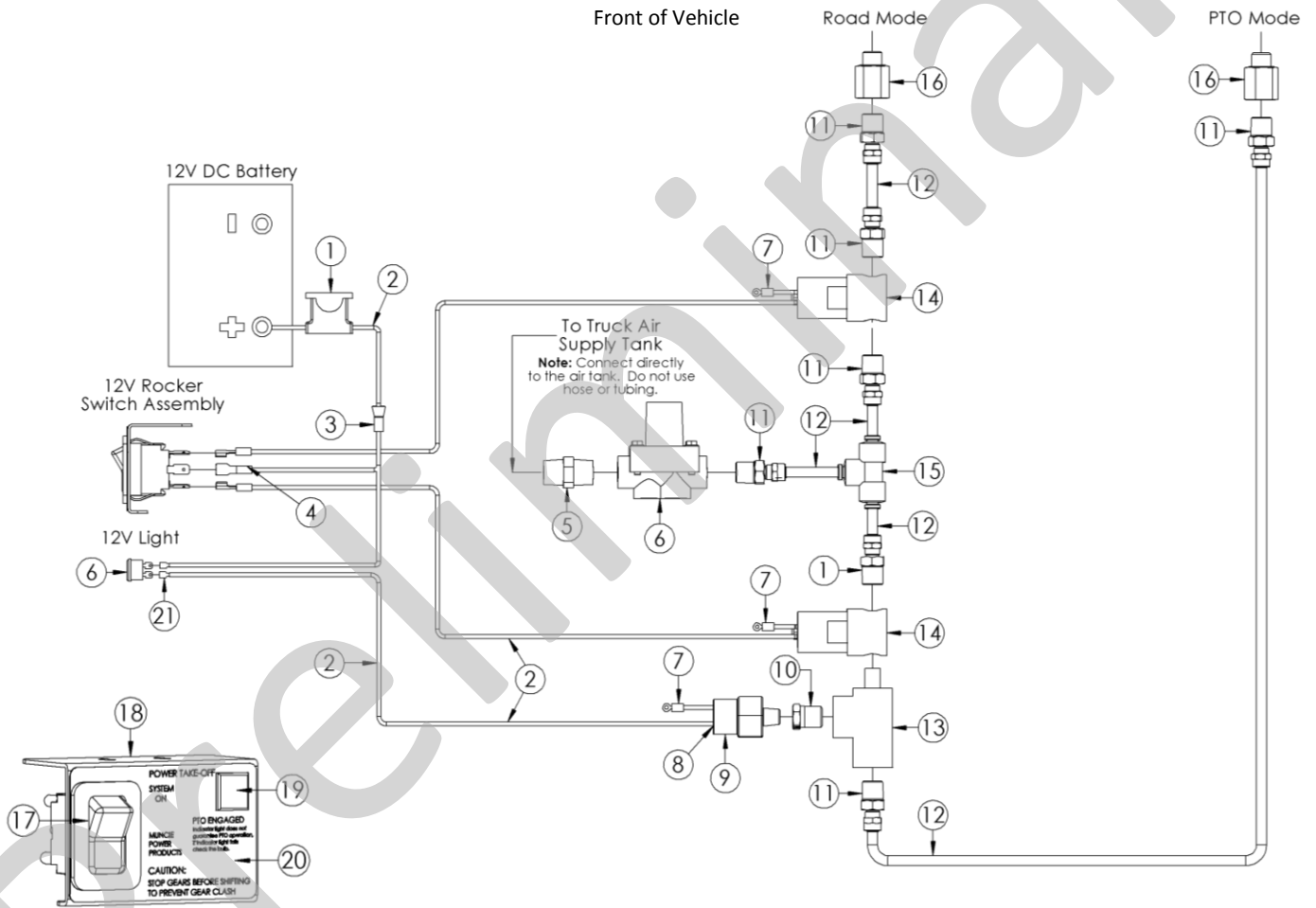
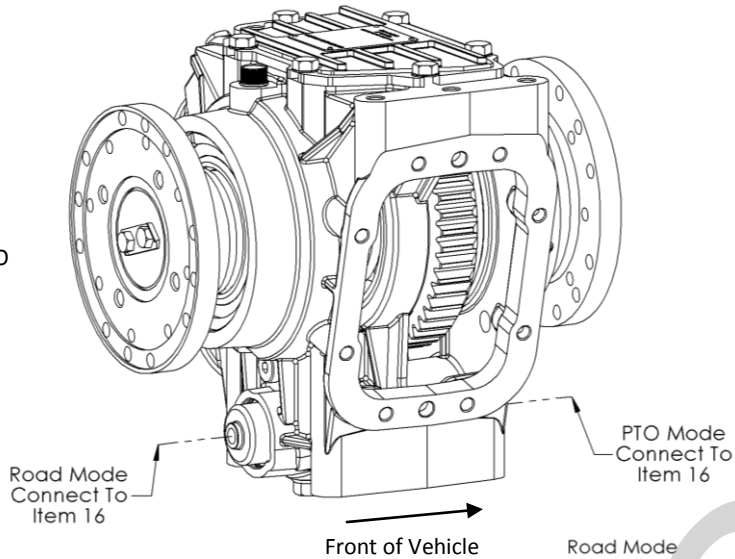

ITEM	QTY	PART NO	DESCRIPTION
1	1	33T36299	Fuse Assembly
2	12.5 Ft.	37M18000	18 Ga. Red Wire
3	6	34T36362	Crimp Connector
4	3	34M18250	Female Spade Connector (1/4")
5	1	44MB2164	1/4" NPT Nipple
6	1	31M15759	Pressure Protection Valve
7	3	34M18009	Ring Terminal
8	1	34T36941	Harness Pigtail
9	1	30T37954	Pressure Switch
10	1	44MB0942	Reducer Bushing
11	7	44MB6844PTC	Push To Connect Tube Fitting

ITEM	QTY	PART NO	DESCRIPTION
12	1	45M44430	Air Tubing 30 Ft.
13	1	44MB2254	1/4" Street Tee
14	2	35M30692	12V Solenoid NC
15	1	44T40394	1/4" Tee Fitting
16	2	44T38628	12mm x 1/4 NPT Adapter
17	1	30T41994	12V Rocker Switch
18	1	36MA1005	Dash Bracket
19	1	32MSR12V	12V Light
20	1	36T35431	Face Plate
21	2	34M18187	Female Spade Connector (3/16")
22	N.S.	36MK1007	Bolt Kit

Manual Transmission

Engaging the Split Shaft

1. Stop the vehicle and put the transmission in neutral.
2. Apply the parking brake and block wheels (if the unit is to operate while the vehicle is stationary).
3. For stationary operation: Shift the main shaft air control (double acting) to disconnect the drive to the rear axle.
4. With the engine at idle; engage the required PTO output(s) by operating the relevant air controls.
5. Depress the clutch pedal and select the required gear. The output shaft speeds are dependent on the main transmission gear selection. Use caution if placing the transmission into reverse as it may cause damage to the driven component(s).
6. Slowly release the clutch pedal; if the Split Shaft is not disengaged from the rear axle, release the parking brake to allow the vehicle to be driven at application rate.
7. For stationary operation: Set the engine speed to the required RPM.

Disengaging the Split Shaft

1. Return the engine speed to idle.
2. Depress the clutch pedal and place the transmission in neutral.
3. Set the parking brake if vehicle has been used in mobile application.
4. Disengage the PTO output(s) by operating the relevant air control(s).
5. Shift the main air control (double acting) to re-engage the drive to the rear axle.
6. Remove the wheel blocks, if stationary application.
7. All PTO outputs are now disengaged. The vehicle can be driven as normal.

Automatic Transmission

Engaging the Split Shaft

1. Stop the vehicle and put the transmission in neutral.
2. Apply the parking brake and block wheels (if the unit is to operate while the vehicle is stationary).
3. For stationary operation: Shift the main shaft air control (double acting) to disconnect the drive to the rear axle.
4. Engage the required PTO output(s) by operating the relevant air control(s).
5. Shift transmission into the required gear selection. Use caution if placing the transmission into reverse as it may cause damage to the driven component(s).
6. Stationary application: Using a method specified by the transmission manufacturer, shift transmission into direct drive.
Mobile application: If Split Shaft is not disengaged from the rear axle, release parking brake to allow vehicle to be driven at application rate.
7. For stationary operation: Set the engine speed to the required RPM.

Disengaging the Split Shaft

1. Be sure vehicle is stopped and apply parking brake.
2. Shut off the engine with transmission in drive mode.
3. Set the parking brake if vehicle has been used in mobile application.
4. Disengage the PTO output(s) by operating the relevant air control(s).
5. Shift transmission into neutral.
6. Remove the wheel blocks.
7. Restart the engine.
8. Shift the main air control (double acting) to re-engage the drive to the rear axle.
9. All PTO outputs are now disengaged. The vehicle can be driven as normal.

Failure to follow proper shifting or operating sequences will result in premature PTO failure with possible damage to the equipment.

POWER TAKE-OFF WARRANTY

The Muncie Power Take-Off is warranted to be free of defects in material or workmanship and to meet Muncie's standard written specifications at the time of sale. Muncie's obligation and liability under this warranty is expressly limited to repairing or replacing, at Muncie's option, within one year after date of original installation any defective part or parts or any product not meeting the specifications.

THIS WARRANTY IS IN LIEU OF ALL OTHER WARRANTIES, EXPRESSED OR IMPLIED. MUNCIE MAKES NO WARRANTY OF MERCHANTABILITY OR OF FITNESS FOR ANY PARTICULAR PURPOSE. MUNCIE'S OBLIGATION UNDER THIS WARRANTY SHALL NOT INCLUDE ANY TRANSPORTATION CHARGES OR COSTS OF INSTALLATION OR ANY LIABILITY FOR DIRECT, INDIRECT SPECIAL, INCIDENTAL, OR CONSEQUENTIAL DAMAGES OR DELAY. THE REMEDIES SET FORTH HEREIN ARE EXCLUSIVE, AND MUNCIE'S LIABILITY WITH RESPECT TO ANY CONTRACT OR SALE OR ANYTHING DONE IN CONNECTION THEREWITH, WHETHER IN CONTRACT, IN TORT, UNDER ANY WARRANTY, OR OTHERWISE, SHALL NOT, EXCEPT AS EXPRESSLY PROVIDED HEREIN, EXCEED THE PRICE OF THE PRODUCT OR PART ON WHICH SUCH LIABILITY IS BASED.

If requested by Muncie, products or parts for which a warranty claim is made are to be returned transportation prepaid to a Muncie Service Center. Any installation or use not in accordance with catalogue or package instructions, other improper use, operation beyond capacity, substitution of parts not approved by Muncie, use with equipment other than the equipment on which the Power Take-Off is first installed, or alteration or repair made to the Power Take-Off other than at a Muncie Service Center shall void this warranty. No employee or representative of Muncie is authorized to change this warranty in any way or to grant any other warranty.

Preliminary



IN11-03 Printed in the U.S.A.
© Muncie Power Products, Inc. 2011

Muncie Power Products, Inc. Member of the Interpump Hydraulics Group
General Offices and Distribution Center • P.O. Box 548 • Muncie, IN 47308-0548
(765)284-7721 • FAX • (765) 284-6991 • E-mail info@munciepower.com
Web site <http://www.munciepower.com>
Drive Products, Exclusive Agents for Canada, ISO Certified by an Accredited Registrar

