



Muncie[®]
Power
Products

KEEP IN VEHICLE
READ OPERATING INSTRUCTIONS
INSIDE BEFORE OPERATING PTO

HINO PTO INTERFACE

PTO INSTALLATION AND OPERATOR'S MANUAL

FOR HINO Model Year 2021 & Later
with Allison 2500 With CS6B-A67**-S3*2 PTO

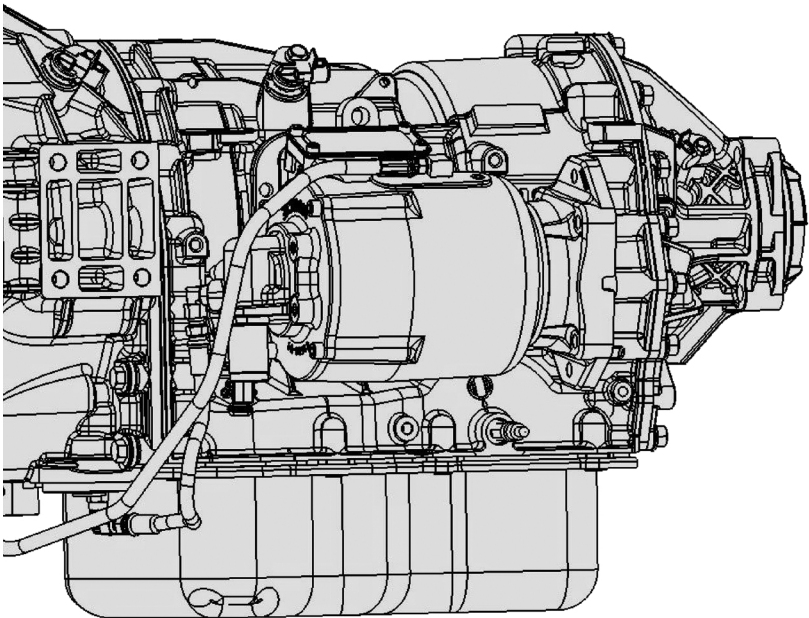

















Important Safety Information

WARNING

ALWAYS READ AND UNDERSTAND THE ENTIRE MANUAL COMPLETELY BEFORE INSTALLATION OR OPERATION OF PTO AND DRIVEN EQUIPMENT INCLUDING THESE WARNINGS AND OPERATOR'S INSTRUCTIONS IN SECTION 3!

-  ALWAYS DISENGAGE THE PTO WHEN THE DRIVEN EQUIPMENT IS NOT IN OPERATION
-  DO NOT ATTEMPT TO INSTALL OR SERVICE ANY POWER TAKE--OFF WITH THE TRUCK ENGINE RUNNING. PUT IGNITION KEYS IN YOUR POCKET BEFORE GETTING UNDER TRUCK.
-  DO NOT ALLOW TRUCK ENGINE TO BE STARTED WHILE WORKERS ARE UNDER TRUCK.
-  BEFORE WORKING ON A VEHICLE PLACE TRANSMISSION IN NEUTRAL OR PARK, SET BRAKES, AND IMMOBILIZE TRUCK WHEELS WITH SUITABLE CHOCKS.
-  BE SURE TO BLOCK ANY RAISED BODY OR MECHANISM BEFORE WORKING ON OR UNDER EQUIPMENT.
-  INSTALLED POWER TAKE-OFFS MUST NEVER BE SHIFTED IN OR OUT OF GEAR BY ANY MEANS EXCEPT BY THE CONTROLS IN THE CAB OF THE TRUCK.
-  STAY CLEAR OF SPINNING DRIVESHAFTS TO AVOID BECOMING ENTANGLED AND INJURED.
-  IT SHALL BE THE RESPONSIBILITY OF THE INSTALLER OF A MUNCIE POWER TAKE-OFF TO DECIDE WHETHER TO INSTALL GUARDS IN THE PTO AND/OR DRIVELINE AREA BECAUSE OF POTENTIAL EXPOSURE TO DANGER. THIS IS BECAUSE MOST MUNCIE PTOS ARE INSTALLED BY EQUIPMENT DISTRIBUTORS OR MANUFACTURERS AND THEREFORE, THE RESPONSIBILITY OF THE INSTALLATION IS BEYOND THE CONTROL OF MUNCIE POWER PRODUCTS.
-  OBTAIN PROPER TRAINING BEFORE OPERATING THIS MACHINERY.
-  DO NOT INSTALL OR OPERATE EQUIPMENT WHICH HAS NOT BEEN PROPERLY SPECIFIED FOR YOUR VEHICLE.
-  INSTALLERS ARE TO INSURE THAT PTO COMPONENTS DO NOT INTERFERE WITH ANY CHASSIS COMPONENTS, INCLUDING BUT NOT LIMITED TO VEHICLE CROSSMEMBERS, FRAME RAILS, DRIVESHAFTS, EXHAUSTS, CONVERTERS, FUEL LINES, ETC. WHILE VEHICLE IS STATIONARY OR MOBILE.
-  ALLOW THE VEHICLE, PTO AND DRIVEN EQUIPMENT TO WARM UP WHEN OPERATING IN WEATHER WHERE TEMPERATURES ARE NEAR OR BELOW FREEZING 32° F (0° C).
-  INSTALL SEPARATE CONTROLS FOR PTO AND DRIVEN EQUIPMENT.
-  ALWAYS INSTALL THE SAFETY LABELS PROVIDED AND PLACE THE OPERATOR'S MANUAL IN THE VEHICLE GLOVE COMPARTMENT.

IMPORTANT SAFETY INFORMATION

The PTO is supplied with a packet containing warning labels. If you did not receive any, or if you need extra, you may order them, no charge, by phone, email or mail. They are available through your nearest Muncie distributor or at the number and address below:

1-800-FOR-PTOS (1-800-367-7867)
 Muncie Power Products, Inc.
 P.O. Box 548
 Muncie, IN 47308-0548
 info@munciepower.com
 © Muncie Power Products, Inc. 2010



THIS SYMBOL WARNS OF PERSONAL INJURY OR DEATH.

SECTION 1- PTO INSTALLATION

ALL INSTALLERS MUST READ THE FOLLOWING

PTO AND ACTIVATION KIT INSTALLATION INSTRUCTIONS

Install the CS6 PTO using the included IN84-03 installation instructions. This instruction is for the electrical connections to the Hino provided PTO connections. The PTO is provided with the appropriate harness for this connection.

Always wear safety glasses. Read entire manual before starting installation.

IMPORTANT: Disconnect vehicle battery prior to installing electrical and electric/hydraulic activation kits.

- A.** Vehicle manufacturers may have specific locations for accessing electrical power and activating hydraulics. The body builder manual or company representative for the vehicle chassis should be contacted prior to installing electrical or hydraulic systems.
- B.** Route wires and activation lines away from rotating and high temperature components. Use appropriate looms and bulk head pass-thru's wherever possible to avoid rubbing through insulation or tubing and causing an electrical short or oil leak.
- C.** Follow all Federal Motor Vehicle Safety Standards (FMVSS) for your vehicle.
- D.** Where electrical grounds are indicated, be sure that they are good grounds, with straight paths to the vehicle battery ground. (Many vehicle cabs are insulated from the vehicle frame and a weak ground is a very common cause for malfunctions).
- E.** When installing hydraulic components, be certain to follow common installation and testing procedures. If you are not familiar with acceptable installation procedures request instructions and guidance from the hydraulic equipment supplier.
- F.** Caution should be taken by installer with any PTO installation to insure components do not interfere with any chassis component during installation or when vehicle is operated.
- G.** Cold weather start conditions require that the transmission be started and warmed prior to engaging PTO and using equipment. Hydraulic pumps should be run at idle and under no load conditions to allow oil to warm before activating hydraulic system.

34T44001 WIRING INSTALLATION INSTRUCTIONS

Always wear safety glasses. Read entire manual before starting installation.

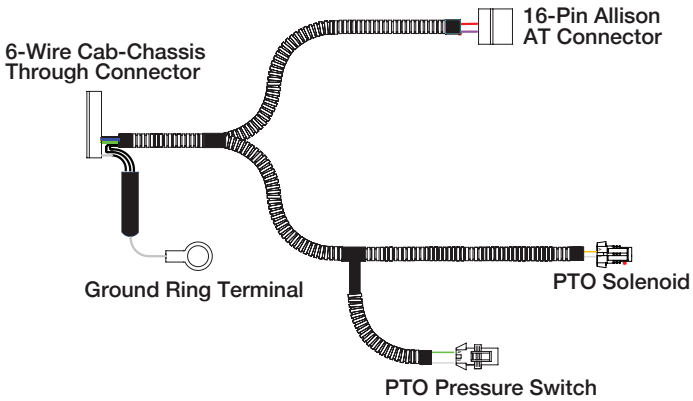
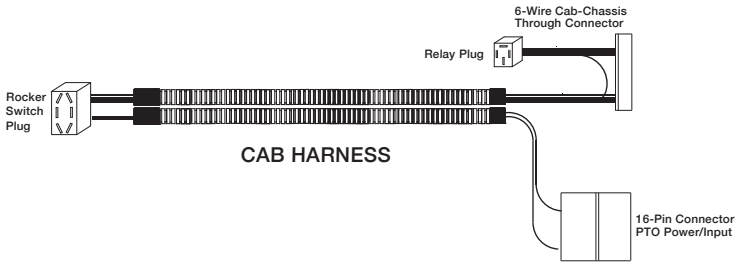

1. Locate the wiring harnesses provided in this kit. The harness can be separated into two sections. The section without the loom is for inside the cab. Pull the fuse access panel from the dash board.



2. Remove the capscrews holding the dash board panel show. Then remove this panel.



INSTALLATION INSTRUCTIONS

Always wear safety glasses. Read entire manual before starting installation.

3. Make following connections using Muncie Cab Harness. Muncie 6-Pin Connector connects to the Hino Connector B. Muncie 16-Pin Connector connects to Hino Connector A

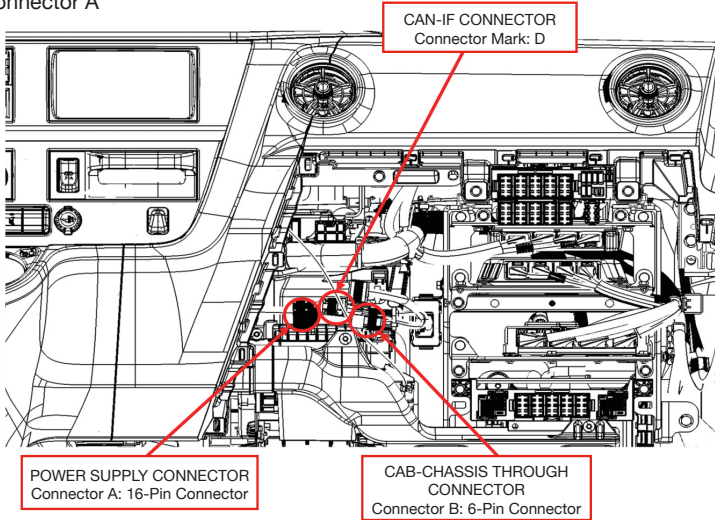

PTO Switch

4. Push out one of the rocker switch plugs from the area next to the steering wheel. Feed the Muncie Cab Harness behind the dash to this hole and connect the rocker switch. Push the switch into position.

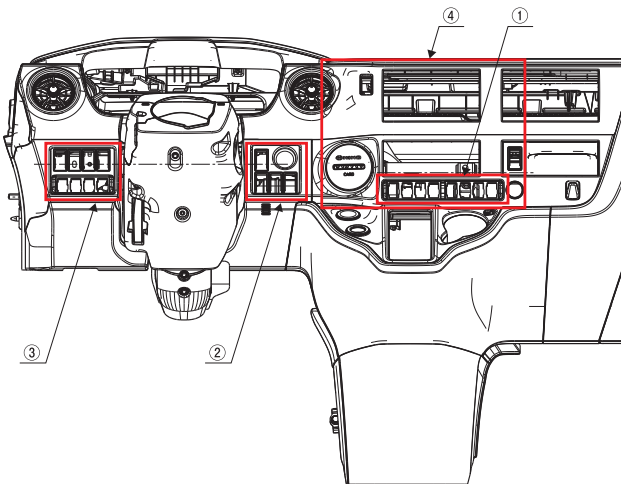

INSTALLATION INSTRUCTIONS

Always wear safety glasses. Read entire manual before starting installation.

- Using the Frame half of the harness with the loom, locate the Hino connector along the right side frame rail behind the cab. Remove the blank plug and connect the Muncie harness to the cab-chassis and Allison connectors. Connect the ground ring terminal to an appropriate ground source. Ground should have a direct path back to truck battery.

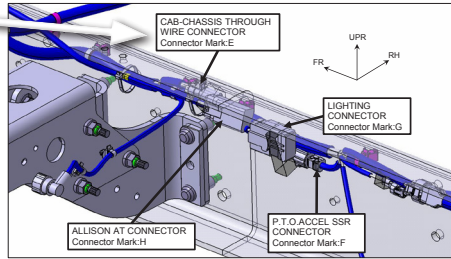

- Route the loomed harness toward the front of the vehicle and make the connections to the Muncie PTO activation solenoid and the pressure switch.
- Near the PTO is a Hino 16-Pin connector for connection to the Allison transmission control and vehicle control. Make this 16-Pin connection and cable tie the PTO harness so that it is contained to the vehicle and away from any rotating component or heat source.
- Check transmission oil level and fill with manufacturer's approved fluid, if necessary and run engine for 5 to 10 minutes to check for leaks, always staying clear of rotating components.

- Complete installation by placing warning labels as indicted on borders of the decals. Placement examples are illustrated on page 5; turn to Section 4 of Operator's Manual.

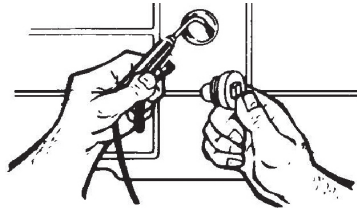

After complete installation, installers need to check for leaks and proper mounting/torque of fasteners. Operate the equipment for an appropriate amount of time to establish proper operation or per the equipment manufacturer's recommendation. After shutting down equipment and engine, check for leaks. Allow unit to set for 60 minutes, then check again for any leaks. Fix all leaks per manufacturer's recommendation.

OPERATOR'S Shifting Procedure & Precautions



WARNING

Power Take-off Operation - Vehicle Stationary

WARNING - parking brake must always be set.

WARNING - vehicle's wheels must always be chocked.

WARNING - transmission must always be in neutral or park.

WARNING - an operator must always be in the driver's seat whenever the engine is running and the transmission is in gear, in order to prevent or stop any unexpected movement of the vehicle which may cause injuries to the operator or others in the vicinity.

- Read all operator's manuals and instructions for the equipment that you are operating on this vehicle.
- Obtain instructions and training for all operations of the equipment on this vehicle including those not covered by this instruction booklet.
- Never work alone when repairing or going under a vehicle for repair or maintenance.
- Always block any raised or moveable components or devices when working on or around the vehicle as specified by the equipment manufacturer.
- Warning: PTOs may drive driven equipment with an exposed drive shaft which may cause severe injury or death if contacted.
- Care must be taken when using a PTO for any specific application that the PTO has been properly specified to match the transmission and auxiliary equipment. Improper specification and installation can cause severe damage to the vehicle transmission and the auxiliary components including driveshafts and driven equipment. Damaged components, equipment resulting in failure can cause serious personal injury to operators and persons in the vicinity.
- Always follow recommended procedures for selecting, installing, operating, or repairing a power take-off as found in Muncie operator's manuals, service parts lists and service manuals, catalogs and application guides.
- Never use a Muncie PTO above the recommended operating speed of the unit or the specified driven unit.
- Never use a power take-off that has not been specified for the output capabilities for the equipment being driven.

Rotating PTO drive shafts

It is recommended that direct couple hydraulic pumps be used whenever possible, but if your application requires the use of an exposed drive shaft it is the responsibility of the installer and purchaser to determine the best installation of a guard.

- Rotating shaft can snag clothing, skin, hands, hair, etc. and will cause serious injury or death.
- Do not go under the vehicle when the engine is running.
- Do not work near an exposed drive shaft with engine running.
- Auxiliary shaft can be installed with recessed or protruding set screws. If raised and square head set screws are chosen, then be aware that this is a catch point for clothes, skin, hair, hands, etc. and serious injury or death may result.

The output shaft of a PTO with internal clutch packs may rotate in cold temperatures with the PTO disengaged. PTO shaft rotation can cause sudden movement of the output shaft and attached drive shaft leading to personal injury or death. Allow transmission to operate for a few minutes before engaging PTO. Allow PTO to operate for a few minutes before actuating application controls.

Some O.E.M. chassis manufacturers have integrated electronic controls which require certain conditions to be met before engaging a PTO. These include, but are not limited to setting parking brake, foot off service brake, engine at idle, foot off accelerator pedal and/or transmission selector in park or neutral.



THIS SYMBOL WARNS OF PERSONAL INJURY OR DEATH

POWER TAKE-OFF WARRANTY

The Muncie Power Take-Off is warranted to be free of defects in material or workmanship and to meet Muncie's standard written specifications at the time of sale. Muncie's obligation and liability under this warranty is expressly limited to repairing or replacing, at Muncie's option, within one year after date of original installation any defective part or parts or any product not meeting the specifications.

THIS WARRANTY IS IN LIEU OF ALL OTHER WARRANTIES, EXPRESSED OR IMPLIED. MUNCIE MAKES NO WARRANTY OF MERCHANTABILITY OR OF FITNESS FOR ANY PARTICULAR PURPOSE. MUNCIE'S OBLIGATION UNDER THIS WARRANTY SHALL NOT INCLUDE ANY TRANSPORTATION CHARGES OR COSTS OF INSTALLATION OR ANY LIABILITY FOR DIRECT, INDIRECT, SPECIAL, INCIDENTAL, OR CONSEQUENTIAL DAMAGES OR DELAY. THE REMEDIES SET FORTH HEREIN ARE EXCLUSIVE, AND MUNCIE'S LIABILITY WITH RESPECT TO ANY CONTRACT OR SALE OR ANYTHING DONE IN CONNECTION THEREWITH, WHETHER IN CONTRACT, IN TORT, UNDER ANY WARRANTY, OR OTHERWISE, SHALL NOT, EXCEPT AS EXPRESSLY PROVIDED HEREIN, EXCEED THE PRICE OF THE PRODUCT OR PART ON WHICH SUCH LIABILITY IS BASED.

If requested by Muncie, products or parts for which a warranty claim is made are to be returned transportation prepaid to a Muncie Service Center. Any installation or use not in accordance with catalogue or package instructions, other improper use, operation beyond capacity, substitution of parts not approved by Muncie, use with equipment other than the equipment on which the Power Take-Off is first installed, or alteration or repair made to the Power Take-Off other than at a Muncie Service Center shall void this warranty. No employee or representative of Muncie is authorized to change this warranty in any way or to grant any other warranty.



**Muncie[®]
Power
Products**

A Member of the Interpump Group

201 East Jackson Street, Muncie, Indiana 47305
800-367-7867 • Fax: 765-284-6991
info@munciepower.com

Specifications are subject to change without notice.
Visit www.munciepower.com for warranties and literature.
All rights reserved. © Muncie Power Products, Inc. (2022)