

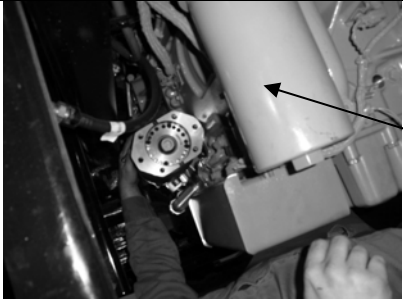

### SUPPLEMENT INSTRUCTION FOR PTO MOUNTING ON CATERPILLAR CX-31 AUTOMATIC TRANSMISSIONS

Read completely the IN95-02 installation and owner's manual supplied with this PTO.

Page 1.11 shows the pressure port locations for hydraulic activation pressure to activate the PTO. This document contains additional instructions.

<p>Determine the clearance needed rearward of the PTO. If the installed oil filter canister is blocking the path needed for your application, then remote mounting the filter would be necessary. Contact Caterpillar dealer for assistance.</p>	
<p>Insert a straight adapter (-4 o'ring) into either the side port or the rear port shown in the diagram. (only one activation port is used.)</p>  <p>Adapter is provided in the installation hose kit.</p>	
<p>For direct mount hydraulic pumps, a support bracket is required for a pump weighing more than 40 lbs this includes accessories, hoses and oil. Attach a 4 point bracket with two points to the pump and two points to the transmission.</p>	 <p>Bolt locations for support bracket.</p>

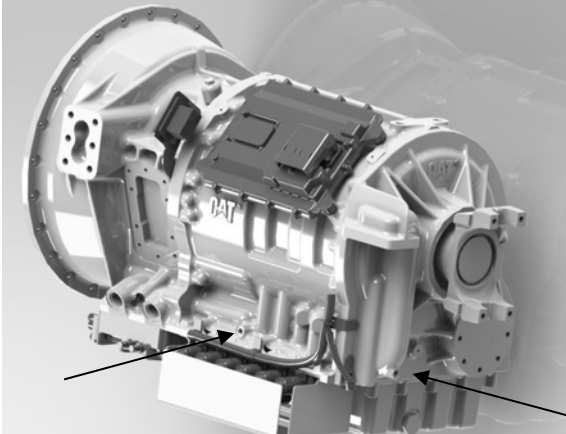
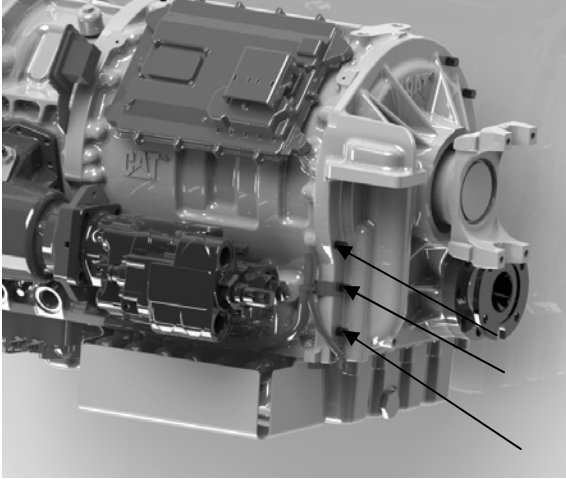
**NOTICE**

If bolts are removed from the CX31 transmission to add mounting brackets, the brackets must be replaced with longer bolts so that thread engagement is maintained. The replacement bolts must be of the same grade and torqued to the required specifications.

Thread engagement length and bolt torques are critical on the Aluminum Case and Cover of the CX Transmissions. The bolts selected for aluminum threaded bores must have a thread engagement length of twice the bolt diameter. Standard torques on short bolts will strip the threads. The bolts must not be too long because the bolts will bottom out and damage the case.

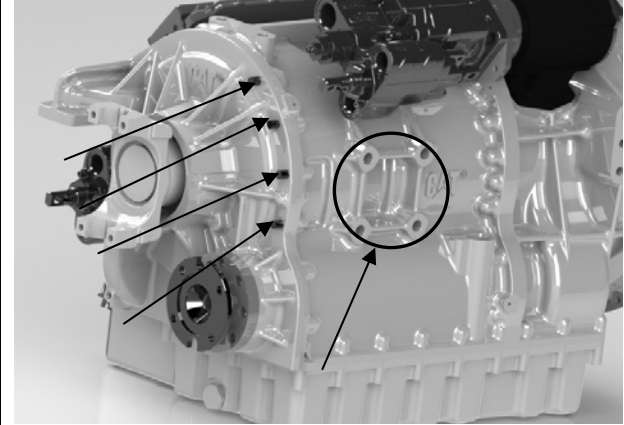

Bolt locations for support bracket.

On the 2011 CT660 the dipstick is mounted over the top PTO opening and the PTO cannot be mounted on this opening without rerouting of the dipstick. At time of printing there is no known fix for this. Contact dealer for further information.

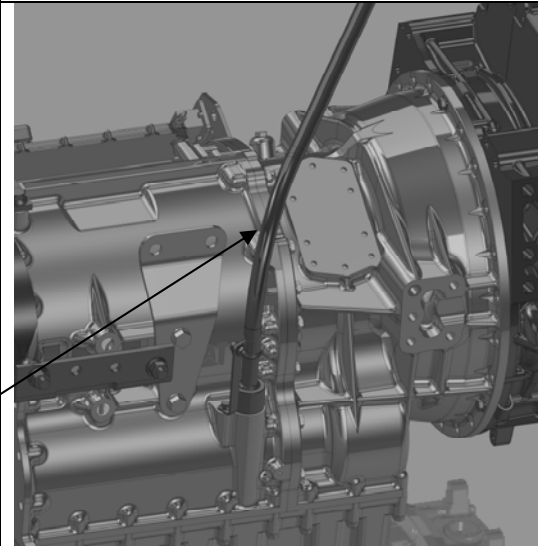

Dipstick Interference on Top Opening.

On chassis with dual fuel tanks mounted on the left side frame rail (Tractor chassis), the crossover line may interfere with the clearance to the rear of the PTO opening.

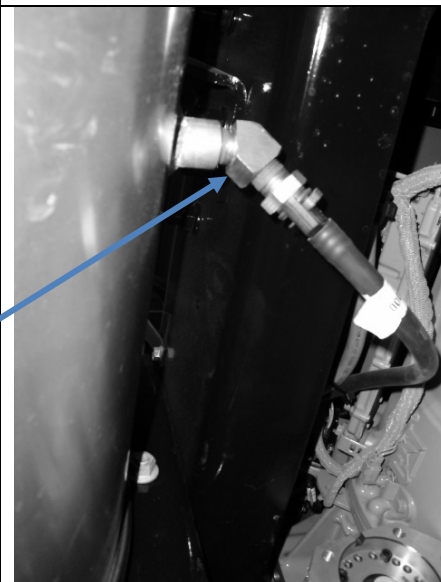

STANDARD CS24 INSTALLATION:

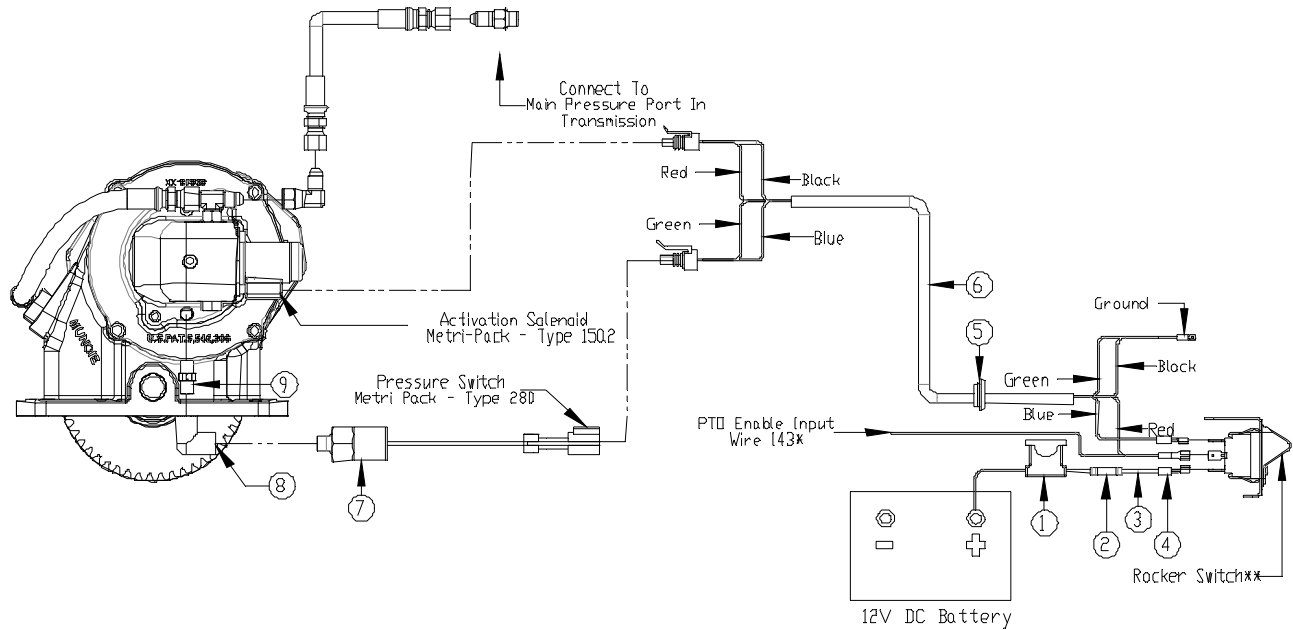

CATERPILLAR IN-DASH-SWITCH:

The Caterpillar CT660 can be ordered with a PTO dash switch. This dash switch controls a pneumatic air valve. Since the CS24 is an hydraulic shifted PTO and is not designed or approved for pneumatic engagement, then the dash switch either needs to be rewired or a pneumatic pressure needs to be used to turn on the hydraulic solenoid valve mounted on the PTO. Muncie PN 48T39261 includes a pressure switch and fitting which allows the CS24 to be activated with this dash switch and solenoid valve.

ITEM	QTY	PART NO.	DESCRIPTION
1	1	44MB6842PTC	TUBE FITTING
2	1	44T35791	COUPLER
3	1	31M14732	PRESSURE SWITCH
4	2	34T36641	FORK TERMINAL
5	*	33T36299	FUSE ASSY.

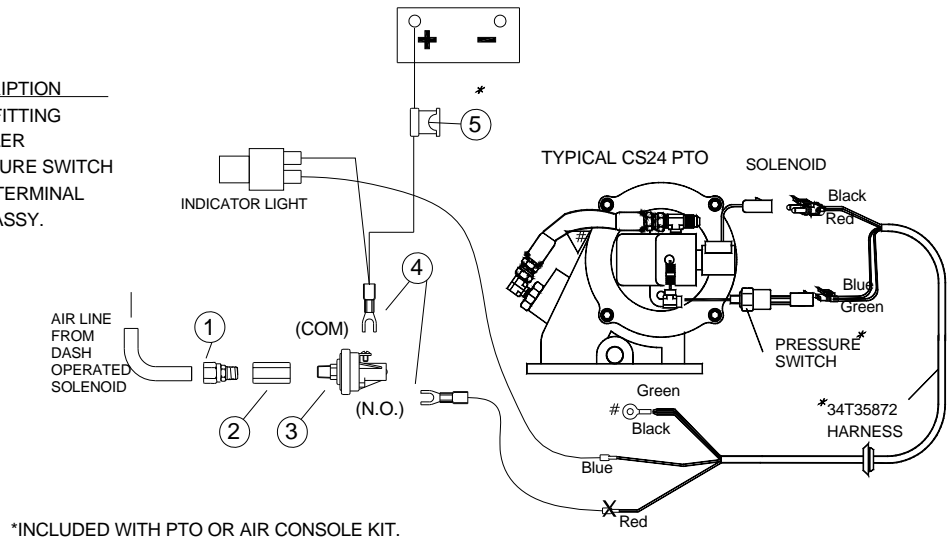

The pneumatic solenoid can be used on the CX-31 vehicle only to switch a pressure switch connected to the PTO. This can be accomplished using the kit listed above.

Should you desire the PTO switch to operate the electric hydraulic solenoid valve installed on the PTO, then connection to the TCU will be required. The PTO switch installed will activate the pneumatic solenoid valve from PIN #6 of the 70 PIN connector. This connector is located on the side of the transmission see the figure.

You can follow this wire to the solenoid block in the engine compartment and connect the 12v power connection here.

