



MUNCIE POWER PRODUCTS

Product Bulletin #00113

Subject: Muncie Power F22 Series PTO Production Launch

Date: February 21, 2023

The Muncie Power F22 Series power take-off for the new 2024 Ford F-650 and F-750 diesel trucks is now available for order, effective immediately.

The [F22 Series PTO](#) is designed to fit model year 2024 and later Ford F-650 and F-750 trucks with diesel engines. The transmission model is the 10R140 TorqShift® Heavy Duty, 10-speed automatic transmission.

All model year 2024 and later diesel F-650 and F-750 trucks will come standard with PTO capability.

Specifications for the F22 Series PTO are as follows:

- Intermittent torque rating of 261 lbs. ft.
- Single ratio for 130% of engine speed
- Features patented noise abatement technology
- New plug & play PTO RPM Module
- Available with Muncie Start®

Below is the model number construction chart for the F22 Series.

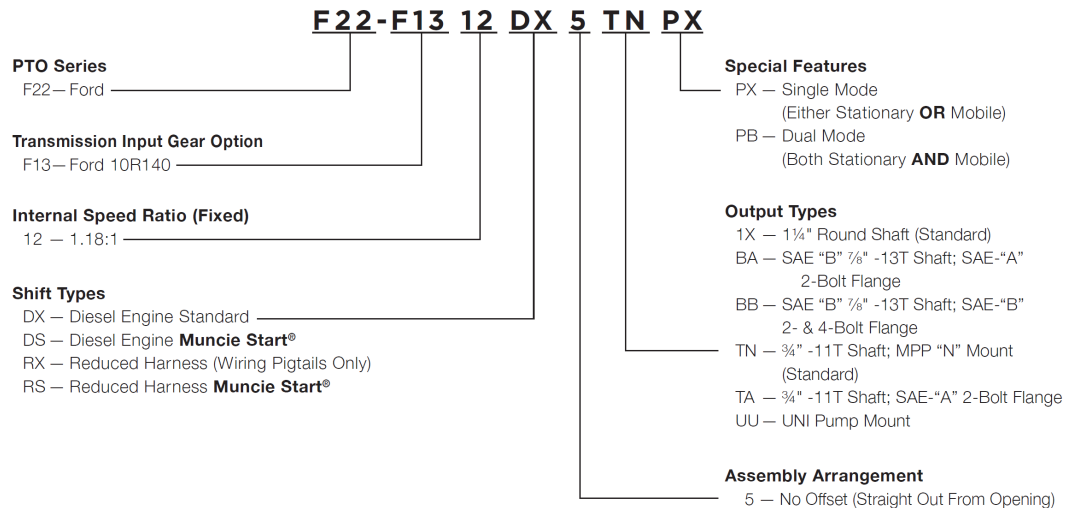

WE BUILD
TRUST.



MUNCIE POWER PRODUCTS

Applicable Literature:

MP22-02	F22 Series Brochure
IN22-09	F22 Series Installation Manual
IN17-04	PTO Operator's Manual
IN22-08	PTO RPM Module Installation Instruction
IN19-07	"R" Shift Harness Installation Instruction
IN17-14	Muncie Start® Installation Instruction
SP22-06	F22 Series PTO Parts and Service Manual

Note: Model year 2024 F-650 and F-750 gas engine trucks will still use the Ford 6R140 TorqShift® transmission, which uses Muncie Power's [FR6Q Series PTO](#).

For more information, please contact the Muncie Power Customer Service team at munciepower.com/contact.

WE BUILD
TRUST.