



# **2018 TRANSMISSION INDEX SECTION**

**This index includes current popular makes and models. For older transmissions not listed contact Muncie Power Products.**



# 2018 TRANSMISSION INDEX

LET. CODE	MAKE MODEL	NO. FWD. SP'DS	DIRECT DRIVE IN.	TEETH IN PTO DRIVER	PTO APPL. NO
-----------	------------	----------------	------------------	---------------------	--------------

## AISIN

450-43LE	.....4.....	3RD	58L	AISN-01
A443	.....4.....	3RD	58L	AISN-01
A445	.....4.....	3RD	58L	AISN-01
A45X2	.....6.....	5TH	69R	AISN-06
A465	.....6.....	5TH	69L	AISN-06
AS68RC	.....6.....	5TH	69R	AISN-02
M036A6	.....6.....	5TH	69L	AISN-06
MY-600	.....6.....	5TH	69L	AISN-06
A460	.....6.....	5TH	63L	AISN-03
A860E	.....6.....	5TH	63L	AISN-03
AS69RC (DIESEL)	.....6.....	5TH	69L or 69L	AISN-04
A467	.....6.....	5TH	69L	AISN-04
AS66RC (GAS)	.....6.....	5TH	69R or 69L	AISN-05

## ALLISON

There are many older model Allison transmissions not listed here for which Muncie can provide PTOs. Contact the Muncie Sales Department for assistance with these models.

1000 SERIES (EVS, RDS, SPS, MHS, BUS, TRV)	.....5.....	4TH	64R&64L	ALLI-09
2000 SERIES (EVS, RDS, SPS, MHS, BUS, TRV)	.....5.....	4TH	64R&64L	ALLI-09
3000* Series (EVS,RDS,SPS)	.....5.....	4TH	68R&68L	ALLI-05
3000* Series (MHS,BUS,TRV) Optional	.....5.....	4TH	68R&68L	ALLI-05
3700, 3700 SPS	.....7.....	4TH	68L	ALLI-11
4000* Series (EVS,RDS,SPS)	.....5.....	4TH	97R&97L	ALLI-06
4000* Series (MHS,BUS,TRV) Optional	.....5.....	4TH	97R&97L	ALLI-06
6310xxxxxx Serial No. 1000 or 2000 Series	.....5.....	4TH	64R&64L	ALLI-09
6311xxxxxx Serial No. 1000 Series	.....6.....	4th	64R&64L	ALLI-09
6510xxxxxx Serial No. 3000* Series	.....5.....	4TH	68R&68L	ALLI-05
6520xxxxxx Serial No. 3000* Series	.....5.....	4TH	68R&68L	ALLI-05
6610xxxxxx Serial No. 4000* Series	.....5.....	4TH	97R&97L	ALLI-06
AT-1542	.....4.....	4TH	55R	ALLI-01
AT-1545	.....4.....	4TH	55R	ALLI-01
AT-540	.....4.....	4TH	55R	ALLI-01
AT-542	.....4.....	4TH	55R	ALLI-01
AT-543	.....4.....	4TH	55R	ALLI-01
AT-545	.....4.....	4TH	55R	ALLI-01
CLBT-5961*	.....6.....	5TH	52R&39T	ALLI-08
CLBT-5963*	.....6.....	5TH	52R&39T	ALLI-08
CLBT-6061*	.....6.....	5TH	52R&39T	ALLI-08
CLBT-6062*	.....6.....	5TH	52R&39T	ALLI-08
CLBT-6063*	.....6.....	5TH	52R&39T	ALLI-08
CLBT-750	.....5.....	5TH	78L	ALLI-03
CLBT-750 (OPTIONAL 8-BOLT OPENINGS)*	.....5.....	5TH	40T&64L	ALLI-04
CLBT-9681*	.....6.....	5TH	52R&39T	ALLI-07
CLT-5961*	.....6.....	5TH	52R&39T	ALLI-08
CLT-5963*	.....6.....	5TH	52R&39T	ALLI-08
CLT-6061*	.....6.....	5TH	52R&39T	ALLI-08
CLT-6062*	.....6.....	5TH	52R&39T	ALLI-08
CLT-6063*	.....6.....	5TH	52R&39T	ALLI-08
CLT-750	.....5.....	5TH	78L	ALLI-03
CLT-750 (OPTIONAL 8-BOLT OPENINGS)*	.....5.....	5TH	40T&64L	ALLI-04
CLT-9884*	.....6.....	5TH	52R&39T	ALLI-07
CLT-9885*	.....6.....	5TH	52R&39T	ALLI-07
DP-8861*	.....6.....	5TH	52R&39T	ALLI-07
DP-8862*	.....6.....	5TH	52R&39T	ALLI-07
DP-8960*	.....6.....	5TH	52R&39T	ALLI-07
DP-8961*	.....6.....	5TH	52R&39T	ALLI-07

LET. CODE	MAKE MODEL	NO. FWD. SP'DS	DIRECT DRIVE IN.	TEETH IN PTO DRIVER	PTO APPL. NO
-----------	------------	----------------	------------------	---------------------	--------------

## ALLISON (Continued)

DP-8962*	.....6.....	5TH	52R&39T	ALLI-07
DP-8963*	.....6.....	5TH	52R&39T	ALLI-07
HD-4060P*	.....6.....	4TH	97R&97L	ALLI-06
HD-4070P*	.....7.....	4TH	97R&97L	ALLI-06
HD-4560P*	.....6.....	4TH	97R&97L	ALLI-06
HT-740	.....4.....	4TH	78L	ALLI-03
HT-740 (OPTIONAL 8-BOLT OPENINGS)*	.....4.....	4TH	40T&64L	ALLI-04
HT-740D	.....4.....	4TH	78L	ALLI-03
HT-740D (OPTIONAL 8-BOLT OPENINGS)*	.....4.....	4TH	40T&64L	ALLI-04
HT-740DT	.....4.....	4TH	78L	ALLI-03
HT-740DT (OPTIONAL 8-BOLT OPENINGS)*	.....4.....	4TH	40T&64L	ALLI-04
HT-740FS	.....4.....	4TH	78L	ALLI-03
HT-740FS (OPTIONAL 8-BOLT OPENINGS)*	.....4.....	4TH	40T&64L	ALLI-04
HT-740FTS	.....4.....	4TH	78L	ALLI-03
HT-740FTS (OPTIONAL 8-BOLT OPENINGS)*	.....4.....	4TH	40T&64L	ALLI-04
HT-740RS	.....4.....	4TH	78L	ALLI-03
HT-740RS (OPTIONAL 8-BOLT OPENINGS)*	.....4.....	4TH	40T&64L	ALLI-04
HT-741	.....4.....	4TH	78L	ALLI-03
HT-741 (OPTIONAL 8-BOLT OPENINGS)*	.....4.....	4TH	40T&64L	ALLI-04
HT-745	.....4.....	4TH	78L	ALLI-03
HT-745 (OPTIONAL 8-BOLT OPENINGS)*	.....4.....	4TH	40T&64L	ALLI-04
HT-747	.....4.....	4TH	78L	ALLI-03
HT-747 (OPTIONAL 8-BOLT OPENINGS)*	.....4.....	4TH	40T&64L	ALLI-04
HT-748	.....4.....	4TH	78L	ALLI-03
HT-748 (OPTIONAL 8-BOLT OPENINGS)*	.....4.....	4TH	40T&64L	ALLI-04
HT-750CRD	.....5.....	5TH	78L	ALLI-03
HT-750CRD (OPTIONAL 8-BOLT OPENINGS)*	.....5.....	5TH	40T&64L	ALLI-04
HT-750DR	.....5.....	5TH	78L	ALLI-03
HT-750DR (OPTIONAL 8-BOLT OPENINGS)*	.....5.....	5TH	40T&64L	ALLI-04
HT-750DRD	.....4.....	4TH	78L	ALLI-03
HT-750DRD (OPTIONAL 8-BOLT OPENINGS)*	.....4.....	4TH	40T&64L	ALLI-04
HT-754CR	.....5.....	5TH	78L	ALLI-03
HT-754CR (OPTIONAL 8-BOLT OPENINGS)*	.....5.....	5TH	40T&64L	ALLI-04
HT-754CRD	.....5.....	5TH	78L	ALLI-03
HT-754CRD (OPTIONAL 8-BOLT OPENINGS)*	.....5.....	5TH	40T&64L	ALLI-04
HT-755CR	.....5.....	5TH	78L	ALLI-03
HT-755CR (OPTIONAL 8-BOLT OPENINGS)*	.....5.....	5TH	40T&64L	ALLI-04
HT-755DR	.....5.....	5TH	78L	ALLI-03
HT-755DR (OPTIONAL 8-BOLT OPENINGS)*	.....5.....	5TH	40T&64L	ALLI-04
M5600*	.....6.....	5TH	46R&36T	ALLI-08
M5610*	.....6.....	5TH	46R&36T	ALLI-08
M6600*, H6600*	.....6.....	5TH	46R&36T	ALLI-08
M6610*, H6610*	.....6.....	5TH	46R&36T	ALLI-08
M8610*, H8610*	.....6.....	5TH	52R&39T	ALLI-07

\* These transmissions have PTO openings in front of the torque converter and are directly engine driven. Clutch shift type PTOs only are recommended unless non-shiftable (constant mesh) PTOs can be utilized.



# 2018 TRANSMISSION INDEX

LET. CODE	MAKE MODEL	NO. FWD. SP'DS	DIRECT DRIVE IN.	TEETH IN PTO DRIVER	PTO APPL. NO
-----------	------------	----------------	------------------	---------------------	--------------

## ALLISON (Continued)

M9600*, H9600*	6	5TH	52R&39T	ALLI-07
M9610*, H9610*	6	5TH	52R&39T	ALLI-07
M9810*, H9810*	8	7TH	52R&39T	ALLI-07
MD-3050P*	5	4TH	68R&68L	ALLI-05
MD-3060P W/ TOP OPENING	6	4TH	83T&83L	ALLI-10
MD-3060P*	6	4TH	68R&68L	ALLI-05
MD-3066P W/ TOP OPENING	6	4TH	83T&83L	ALLI-10
MD-3066P*	6	4TH	68R&68L	ALLI-05
MD-3070PT*	7	N.A.	68L	ALLI-11
MD-3550P*	5	4TH	68R&68L	ALLI-05
MD-3560P W/ TOP OPENING	6	4TH	83T&83L	ALLI-10
MD-3560P*	6	4TH	68R&68L	ALLI-05
MD-3566P*	6	4TH	68R&68L	ALLI-05
MT-640	4	4TH	64R	ALLI-02
MT-643	4	4TH	64R	ALLI-02
MT-644	4	4TH	64R	ALLI-02
MT-644CR	4	4TH	64R	ALLI-02
MT-647	4	4TH	64R	ALLI-02
MT-648	4	4TH	64R	ALLI-02
MT-650	5	5TH	64R	ALLI-02
MT-653	4	4TH	64R	ALLI-02
MT-653DR	5	5TH	64R	ALLI-02
MT-654CR	5	5TH	64R	ALLI-02
S5600*	6	5TH	46R&36T	ALLI-08
S6600*, SS620	6	5TH	46R&36T	ALLI-08
S8610*	8	7TH	52R&39T	ALLI-07
S9600*	8	7TH	52R&39T	ALLI-07
S9610*	8	7TH	52R&39T	ALLI-07
S9800*, H9800*	8	7TH	52R&39T	ALLI-07
S9805*	8	7TH	52R&39T	ALLI-07
S9806*	8	7TH	52R&39T	ALLI-07
S9810*, S9820*	8	7TH	52R&39T	ALLI-07
TC-10-TS	10	10TH	REAR	ALLI-12
98100FS*	8	7TH	52R&39T	ALLI-07
98230FS*	8	7TH	52R&39T	ALLI-07
98260FS*	8	7TH	52R&39T	ALLI-07

## CATERPILLAR

TH48FT-E80	6	4TH	57R&57L	CATT-04
TH55FT-E70	6	4TH	75R	CATT-05

## CHELSEA

4700A			39R&39L	CHEL-01
4700H			39R&39L	CHEL-01
4900			39R&39L	CHEL-01
910AK			39R&39L	CHEL-01
911AK			39R&39L	CHEL-01
912AH			39R&39L	CHEL-02
941 1			23R&23L	CHEL-03

## CHEVY/GMC

M69 - FULLER FSO-8406A	6	5TH	48R&48L	FULL-49
M74 - ALLISON 1000 3500 Cab Chassis	5	4TH	64R&64L	ALLI-09
M74 - ALLISON 1000 C4500-C5500 Chs.	5	4TH	64R&64L	ALLI-09
MBV - ALLISON 1000 RDS	5	4TH	64R&64L	ALLI-09
MBW - ALLISON 1000 EVS	5	4TH	64R&64L	ALLI-09
MBZ - ALLISON 2200 RDS	5	4TH	64R&64L	ALLI-09
MHD - ALLISON 2350 EVS	5	4TH	64R&64L	ALLI-09
MHE - ALLISON 2350 RDS	5	4TH	64R&64L	ALLI-09
MK8 - TTC/SPICER ES56-7B	7	7TH	34R&34L	SPCR-56
MK9 - TTC/SPICER ESO66-7B	7	6TH	34R&34L	SPCR-29
MKO - FULLER FS-6305A	5	5TH	39R&39L	FULL-11
MLO - FULLER FS-6305B	5	5TH	41R&41L	FULL-12

LET. CODE	MAKE MODEL	NO. FWD. SP'DS	DIRECT DRIVE IN.	TEETH IN PTO DRIVER	PTO APPL. NO
-----------	------------	----------------	------------------	---------------------	--------------

## CHEVY/GMC (Continued)

MM7 - FULLER FS-5406A	6	6TH	38R&38L	FULL-09
MM8 - FULLER FS-6406A	6	6TH	38R&38L	FULL-09
MPQ - ALLISON 2550 RDS	5	4TH	64R&64L	ALLI-09
MPR - ALLISON 2550 EVS	5	4TH	64R&64L	ALLI-09
MPS - ALLISON 2500 RDS	5	4TH	64R&64L	ALLI-09
MPU - FULLER FS-5205A	5	5TH	33R&19L	FULL-07
MS9 - FULLER RT-8709B	9	9TH	45R&47B	FULL-25
MSC - FULLER FS-4205B	5	5TH	28R&28L	FULL-06
MSG - FULLER FS-4205A	5	5TH	28R&28L	FULL-05
MT3 - FULLER RT-8709B	10	8TH	45R&47B	FULL-25
MTX - ALLISON 2200 RDS	5	4TH	64R&64L	ALLI-09
MTY - ALLISON 2300 RDS	5	4TH	64R&64L	ALLI-09
MUT - FULLER RT-6609A	9	9TH	33R&33B	FULL-15
MW7 - ALLISON 1000 3500 Cab Chassis 2007-2012	6	4TH	64R&64L	ALLI-09
MWT - ALLISON 3000 RDS	5	4TH	68R&68L	ALLI-05
MWU - ALLISON 3000 RDS	5	4TH	68R&68L	ALLI-05
MWY - ALLISON 3000 RDS	5	4TH	68R&68L	ALLI-05
MWZ - ALLISON 3500 RDS	5	4TH	68R&68L	ALLI-05
MY6 - ALLISON 2200 EVS	5	4TH	64R&64L	ALLI-09
SM-420	4	4TH	33L	N2
TDET-1361	5	4TH	33L	TREM-02

## DETROIT DIESEL

DT-12-****-DH1	12	12TH	REAR	MERC-07
DT-12-****-DH8	12	12TH	REAR	MERC-06
DT-12-****-OH1	12	11TH	REAR	MERC-07
DT-12-****-OH8	12	11TH	REAR	MERC-06

## DODGE RAM TRUCK

A45X2	6	5TH	69R	AISN-02
AS68RC	6	5TH	69R	AISN-02
AS69RC	6	5TH	69R	AISN-04

## CLARK\*\*

\*\*Suffixes omitted, eg. 282V20. These only denote options for basic transmissions and do not affect the PTO.

Certain older model Clark transmissions are being manufactured outside the U.S.A. Contact the Muncie Sales Department for application assistance when encountering model numbers not listed here.

280V	5	5TH	40R&20L	CLAR-01
280V0	5	4TH	46R&20L	CLAR-02
282V	5	5TH	42R&20L	CLAR-03
282VHD	5	5TH	42R&20L	CLAR-03
285V	5	5TH	39R&20L	CLAR-04
285VHD	5	5TH	39R&20L	CLAR-04
390V	5	5TH	33R&19L	FULL-07
397V	5	5TH	30R&19L	FULL-08
CL-450 (CLARK)	5	5TH	25R&25L	FULL-02
CL-455 (CLARK)	5	5TH	25R&25L	FULL-03
CL-457 (CLARK)	5	5TH	29R&29L	FULL-04
CL-551	5	5TH	33R&19L	FULL-07
CL-557	5	5TH	30R&19L	FULL-08
CL-558	5	5TH	33R&19L	FULL-07
CL-559A (TREMEC)	5	5TH	33R&19L	FULL-07
CL-559B (TREMEC)	5	5TH	33R&19L	FULL-07
CL-559C (TREMEC)	5	5TH	30R&19L	FULL-08

### Notes:

N2 - Not Current Production Transmission - No Muncie PTO.

\* These transmissions have PTO openings in front of the torque converter and are directly engine driven. Clutch shift type PTOs only are recommended unless non-shiftable (constant mesh) PTOs can be utilized.



# 2018 TRANSMISSION INDEX

LET. CODE	MAKE MODEL	NO. FWD. SP'DS	DIRECT DRIVE IN.	TEETH IN PTO DRIVER	PTO APPL. NO
-----------	------------	----------------	------------------	---------------------	--------------

## DINA

CV31 (SPICER 3153A)	5	5TH	22R&25L	N3
CV32 (SPICER 3853)	5	4TH	22R&25L	N3
CV33 (SPICER 3152)	4	4TH	42R&25L	N3
CV34 (SPICER 3152A)	5	5TH	42R&25L	N3
CV35 (SPICER 3152E)	5	5TH	22R&25L	N3
CV37F (SPICER 3556A)	5	5TH	21R&26L	N3
CV64A (SPICER 6852G)	5	5TH	23R&25L	N3
CV65 (SPICER 6852G)	5	5TH	23R&25L	N3
CV65B (SPICER 6852Q)	5	5TH	23R&25L	N3
CV65E (SPICER 6852Q)	5	5TH	23R&25L	N3
CV66 (SPICER 6853G)	5	5TH	23R&25L	N3
CV66A (SPICER 6853G)	5	5TH	23R&25L	N3
CV67 (SPICER 6853C)	5	5TH	23R&25L	N3
CV67F (SPICER ES65-5D)	5	5TH	42R&42L	SPCR-27

## EATON/FULLER

There are many older model Fuller transmissions not listed for which Muncie can provide PTOs. Contact the Muncie Sales Department for assistance with these models. These models include the 5-speed models currently out of production. (Ex. 5CW, 5AW Series, etc.)

F = If used, F denotes forward position of gear shift lever (RTF-11609A).

Does not affect PTO application.

Older models - AC = AutoClutch does not affect PTO application.

### Road Ranger Model Codes:

O = Used in letter designation indicates overdrive. All overdrives now have direct shift pattern previously given (X) designation. The (X) replaces the overdrive designator (O) in the model number. (RTXF-11609A is same application as RTO-11609A.)

L = Following numbers, used for construction models to denote a low gear in addition to designated speeds (RTO-11919MLL 9+2 low-low gears, total 11 speeds forward.)

F = Designates front shifter and does not affect the PTO application.

2A-92 (AUXILIARY)				N1
3905A	5	5TH	36R	EATN-04
3905B	5	5TH	36R	EATN-04
3905C	5	5TH	36R	EATN-04
4106-A (FRONT OPENING)	6	6TH	45R	EATN-03
4106-B (FRONT OPENING ONLY)	6	6TH	43R	EATN-01
6109-A	9	9TH	23L	EATN-02
AT-1202 (AUXILIARY)	2	1ST	30T&30B	FULL-01
EDCO-6F107-A(P)	7	7TH	47R&23L	FULL-57
EH-8E306A-CD (HYBRID)	6	5TH	48R&48L	FULL-49
EH-8E306A-U (HYBRID)	6	5TH	48R&48L	FULL-49
EH-8E306A-UP (HYBRID)	6	5TH	48R&48L	FULL-49
F-5405B-DM3, F-5505B-DM3	5	5TH	48R	FULL-49
F-6405B-DM3, F-6505B-DM3	5	5TH	48R&48L	FULL-49
F-6406N-ASW	6	6TH	39R&39L	FULL-52
F-8405B-DM3	5	5TH	48R&48L	FULL-49
F-8406N-ASW	6	6TH	39R&39L	FULL-52
F-8406N-AW3	5	5TH	39R&39L	FULL-52
F-14E316B-LSE	16	15TH	45R&47B	FULL-54
F-15E316B-LSE	16	15TH	45R&47B	FULL-54
F-17E316B-LSE	16	15TH	45R&47B	FULL-54
FM-14D310B-LST	10	9TH	45R&47B	FULL-53
FM-15D310B-LST	10	9TH	45R&47B	FULL-53
FM-14E310B-LAS	10	10th	45R&47B	FULL-55
FM-15E310B-LAS	10	10th	45R&47B	FULL-55
FM-15E316B-LSE	16	16TH	45R&47B	FULL-54
FO-5406B-DM3, FO-5506B-DM3	6	5TH	48R	FULL-49
FO-6406A-ASW	6	5TH	48R	FULL-49
FO-6406A-ASX	6	5TH	48R	FULL-49
FO-6406A-AW3	6	5TH	48R&48L	FULL-49
FO-6406B-DM3, FO-6506B-DM3	6	5TH	48R&48L	FULL-49

LET. CODE	MAKE MODEL	NO. FWD. SP'DS	DIRECT DRIVE IN.	TEETH IN PTO DRIVER	PTO APPL. NO
-----------	------------	----------------	------------------	---------------------	--------------

## EATON/FULLER (Continued)

### Medium Duty - Automated Nomenclature

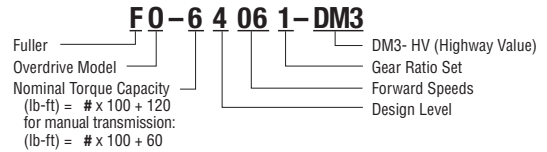

### Medium Duty - Manual Nomenclature

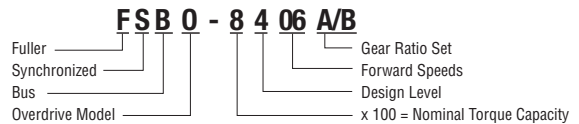

### Heavy Duty - Automated Nomenclature

(reference item RRSLO002 for further nomenclature explanations)

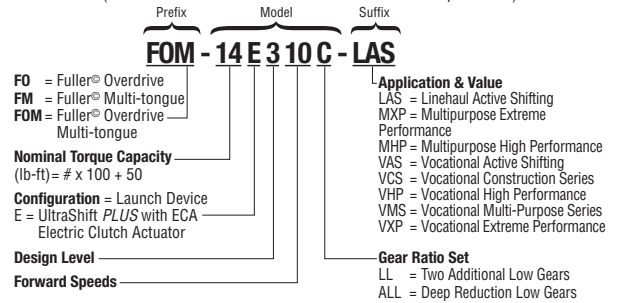

### Heavy Duty - Manual Nomenclature

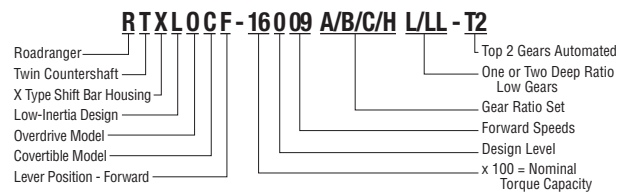

FO-8406A-ASW	6	5TH	48R	FULL-49
FO-8406A-ASX	6	5TH	48R	FULL-49
FO-8406A-AW3	6	5TH	48R&48L	FULL-49
FO-8406B-DM3	6	5TH	48R&48L	FULL-49
FO-10E308LL-VCS	10	9th	45R&47B	FULL-54
FO-10E309ALL-VMS	11	10th	45R&47B	FULL-54
FO-10E310C-VAS	10	9th	45R&47B	FULL-54
FO-11E308LL-VCS	10	9th	45R&47B	FULL-54
FO-11E309ALL-VMS	11	10th	45R&47B	FULL-54
FO-12E308LL-VCS	10	9th	45R&47B	FULL-54
FO-12E309ALL-VMS	11	10th	45R&47B	FULL-54
FO-12E310C-VAS	10	9th	45R&47B	FULL-54
FO-14E308LL-VCS	10	9th	45R&47B	FULL-54
FO-14E309ALL-VMS	11	10th	45R&47B	FULL-54
FO-14E310C-LAS	10	9th	45R&47B	FULL-54
FO-14E310C-VAS	10	9th	45R&47B	FULL-54
FO-14E313A-MHP	13	11th	45R&47B	FULL-54
FO-14E318B-MXP	18	16th	45R&47B	FULL-54
FO-14E318B-VXP	18	16th	45R&47B	FULL-54

### Notes:

N1 - No PTOs Available.

N3 - PTO Application Available From M-Power or Muncie Website.



# 2018 TRANSMISSION INDEX

LET. CODE	MAKE MODEL	NO. FWD. SP'DS	DIRECT DRIVE IN.	TEETH IN PTO DRIVER	PTO APPL. NO
-----------	------------	----------------	------------------	---------------------	--------------

## EATON/FULLER (Continued)

FO-16D313E-LEP	13.....11TH	45R&47B	FULL-54
FO-16E308LL-VCS	10.....9th	45R&47B	FULL-54
FO-16E309ALL-VMS	11.....10th	45R&47B	FULL-54
FO-16E310C-LAS	10.....9th	45R&47B	FULL-54
FO-16E310C-VAS	10.....9th	45R&47B	FULL-54
FO-16E313A-MHP	13.....11th	45R&47B	FULL-54
FO-16E313A-VHP	13.....11th	45R&47B	FULL-54
FO-16E318B-MXP	18.....16th	45R&47B	FULL-54
FO-16E318B-VXP	18.....16th	45R&47B	FULL-54
FO-17E308LL-VCS	10.....9th	45R&47B	FULL-54
FO-17E309ALL-VMS	11.....10th	45R&47B	FULL-54
FO-18E313A-MHP	13.....11th	45R&47B	FULL-54
FO-18E313A-VHP	13.....11th	45R&47B	FULL-54
FO-18E318B-MXP	18.....16th	45R&47B	FULL-54
FO-18E318B-VXP	18.....16th	45R&47B	FULL-54
FO-20E313A-MHP	13.....11th	45R&47B	FULL-54
FO-20E313A-VHP	13.....11th	45R&47B	FULL-54
FO-20E318B-MXP	18.....16th	45R&47B	FULL-54
FO-20E318B-VXP	18.....16th	45R&47B	FULL-54
FO-22E318B-MXP	18.....16th	45R&47B	FULL-54
FO-22E318B-VXP	18.....16th	45R&47B	FULL-54
FOM-14E310C-LAS	10.....9th	45R&47B	FULL-54
FOM-14E310C-VAS	10.....9th	45R&47B	FULL-54
FOM-15E310C-LAS	10.....9th	45R&47B	FULL-54
FOM-15E310C-VAS	10.....9th	45R&47B	FULL-54
FOM-16E310C-LAS	10.....9th	45R&47B	FULL-54
FOM-16E310C-VAS	10.....9th	45R&47B	FULL-54
FO-5406B-DM3	6.....5TH	48R	FULL-49
FO-6406A-ASW	6.....5TH	48R	FULL-49
FO-6406A-ASX	6.....5TH	48R	FULL-49
FO-6406A-AW3	6.....5TH	48R&48L	FULL-49
FO-6406B-DM3	6.....5TH	48R&48L	FULL-49
FO-8406A-ASW	6.....5TH	48R	FULL-49
FO-8406A-ASX	6.....5TH	48R	FULL-49
FO-8406A-AW3	6.....5TH	48R&48L	FULL-49
FO-8406B-DM3	6.....5TH	48R&48L	FULL-49
FOM-16D313E-LEP	13.....11TH	45R&47B	FULL-54
FR(M)-11210B	10.....9TH	45R&47B	FULL-40
FR(M)-12210B	10.....9TH	45R&47B	FULL-40
FR(M)-13210B	10.....9TH	45R&47B	FULL-40
FR(M)-14210B	10.....9TH	45R&47B	FULL-40
FR(M)-15210B	10.....10TH	45R&47B	FULL-40
FR-9210B	10.....9TH	45R&47B	FULL-40
FRLO-14410C-T2	10.....9TH	51R&51L	FULL-50
FRLO-15410C-T2	10.....9TH	51R&51L	FULL-50
FRLO-16410C-T2	10.....9TH	51R&51L	FULL-50
FRLO-18410C-T2	10.....9TH	51R&51L	FULL-50
FRLO-XX410C-T2	10.....9TH	Rear	FULL-51
FRO-11210B	10.....9TH	45R&47B	FULL-39
FRO-11210C	10.....9TH	45R&47B	FULL-38
FRO-12210B	10.....9TH	45R&47B	FULL-39
FRO-12210C	10.....9TH	45R&47B	FULL-38
FRO-13210B	10.....9TH	45R&47B	FULL-39
FRO-13210C	10.....9TH	45R&47B	FULL-38
FRO-14210B	10.....9TH	45R&47B	FULL-39
FRO-14210C	10.....9TH	45R&47B	FULL-38
FRO-15210B	10.....9TH	45R&47B	FULL-39
FRO-15210C	10.....9TH	45R&47B	FULL-38
FRO-16210B	10.....9TH	45R&47B	FULL-39
FRO-16210C	10.....9TH	45R&47B	FULL-38
FRO-17210C	10.....9TH	45R&47B	FULL-38
FRO-18210C	10.....9TH	45R&47B	FULL-38
FRO-9210B	10.....9TH	45R&47B	FULL-39
FS-3005A (1988 & BEFORE)	5.....5TH	25R&25L	FULL-02

LET. CODE	MAKE MODEL	NO. FWD. SP'DS	DIRECT DRIVE IN.	TEETH IN PTO DRIVER	PTO APPL. NO
-----------	------------	----------------	------------------	---------------------	--------------

## EATON/FULLER (Continued)

FS-3005A (1989 & AFTER)	5.....5TH	28R&28L	FULL-05
FS-3005B (1988 & BEFORE)	5.....5TH	25R&25L	FULL-03
FS-3005B (1989 & AFTER)	5.....5TH	28R&28L	FULL-06
FS-3005C	5.....5TH	29R&29L	FULL-04
FS-3205A	5.....5TH	28R&28L	FULL-05
FS-3205B	5.....5TH	28R&28L	FULL-06
FS-3205C	5.....5TH	29R&29L	FULL-04
FS-4005A (BEFORE NOV. 1987)	5.....5TH	25R&25L	FULL-02
FS-4005A (NOV. 1987 & AFTER)	5.....5TH	28R&28L	FULL-05
FS-4005B (BEFORE NOV. 1987)	5.....5TH	25R&25L	FULL-03
FS-4005B (NOV. 1987 & AFTER)	5.....5TH	28R&28L	FULL-06
FS-4005C	5.....5TH	29R&29L	FULL-04
FS-4106A (FRONT OPENING)	6.....6TH	45R	EATN-03
FS-4205A	5.....5TH	28R&28L	FULL-05
FS-4205B	5.....5TH	28R&28L	FULL-06
FS-4205C	5.....5TH	29R&29L	FULL-04
FS-5005A (TREMEC)	5.....5TH	33R&19L	FULL-07
FS-5005B	5.....5TH	33R&19L	FULL-07
FS-5005C	5.....5TH	30R&19L	FULL-08
FS-5005D (TREMEC)	5.....5TH	33R&19L	FULL-07
FS-5106A	6.....6TH	38R&38L	FULL-09
FS-5205A	5.....5TH	33R&19L	FULL-07
FS-5205B	5.....5TH	33R&19L	FULL-07
FS-5205C	5.....5TH	30R&19L	FULL-08
FS-5206A (FRONT OPENING)	6.....6TH	45R	EATN-03
FS-5206B (FRONT OPENING ONLY)	6.....6TH	43R	EATN-01
FS-5306A	6.....6TH	38R&38L	FULL-09
FS-5406A	6.....6TH	38R&38L	FULL-09
FS-5406N	6.....6TH	39R&39L	FULL-52
FS-5506	6.....6TH	50R&50L	FULL-10
FS-6005A	5.....5TH	39R&39L	FULL-11
FS-6005B	5.....5TH	41R&41L	FULL-12
FS-6105A	5.....5TH	39R&39L	FULL-11
FS-6105B	5.....5TH	41R&41L	FULL-12
FS-6106A	6.....6TH	50R&50L	FULL-10
FS-6109A	9.....9TH	23L	EATN-02
FS-6205A	5.....5TH	39R&39L	FULL-11
FS-6205B	5.....5TH	41R&41L	FULL-12
FS-6206A	6.....6TH	38R&38L	FULL-09
FS-6305A	5.....5TH	39R&39L	FULL-11
FS-6305B	5.....5TH	41R&41L	FULL-12
FS-6305N	5.....5TH	39R&39L	N2
FS-6306A, FS-6306B	6.....6TH	38R&38L	FULL-09
FS-6306X	6.....6TH	38R&38L	FULL-09
FS-6309A	9.....9TH	23L	EATN-02
FS-6406A, FS-6406B	6.....6TH	38R&38L	FULL-09
FS-6406N	6.....6TH	39R&39L	FULL-52
FS-7206A	6.....6TH	50R&50L	FULL-10
FS-8206A	6.....6TH	50R&50L	FULL-10
FS-8209A	9.....9TH	23L	EATN-02
FS-8309A	9.....9TH	23L	EATN-02
FSB-5305D	5.....5TH	31R&19L	FULL-48
FSB-5406B	6.....6TH	38R&38L	FULL-09
FSB-6406B	6.....6TH	38R&38L	FULL-09
FSBO-6406B	6.....5TH	48R&48L	FULL-49
FSBO-8406B	6.....5TH	48R&48L	FULL-49
FSM-5005E	5.....5TH	33R&33L	FULL-44
FSM-5005G	5.....5TH	32R&32L	FULL-45
FSM-5005H	5.....5TH	33R&33L	FULL-46
FSM-5005J	5.....5TH	32R&32L	FULL-47
FSM-5305E	5.....5TH	33R&33L	FULL-44

### Notes:

N2 – Not Current Production Transmission – No Muncie PTO.



# 2018 TRANSMISSION INDEX

LET. CODE	MAKE MODEL	NO. FWD. SP'DS	DIRECT DRIVE IN.	TEETH IN PTO DRIVER	PTO APPL. NO
-----------	------------	----------------	------------------	---------------------	--------------

LET. CODE	MAKE MODEL	NO. FWD. SP'DS	DIRECT DRIVE IN.	TEETH IN PTO DRIVER	PTO APPL. NO
-----------	------------	----------------	------------------	---------------------	--------------

## EATON/FULLER (Continued)

FSM-5305G.....	5.....	5TH	32R&32L	FULL-45
FSM-5305H.....	5.....	5TH	33R&33L	FULL-46
FSO-4305A.....	5.....	5TH	36R	EATN-04
FSO-4305B.....	5.....	5TH	36R	EATN-04
FSO-4305C.....	5.....	5TH	36R	EATN-04
FSO-4405A.....	5.....	5TH	36R	EATN-04
FSO-4405B.....	5.....	5TH	36R	EATN-04
FSO-4405C.....	5.....	5TH	36R	EATN-04
FSO-6109A.....	9.....	8TH	23L	EATN-02
FSO-6406A.....	6.....	5TH	48R&48L	FULL-49
FSO-8209A.....	9.....	8TH	23L	EATN-02
FSO-8406A.....	6.....	5TH	48R&48L	FULL-49
FTS-16108LL.....	8.....	8TH	38R&58B	FULL-56
FTS-18109LL.....	8.....	8TH	38R&58B	FULL-56
RT-1110 (F).....	10.....	10TH	45R&47B	FULL-25
RT-11109A-AT.....	9.....	9TH	45R&47B	FULL-34
RT-11109A-ATE (ENGINE DRIVEN OPENING).....			66L	FULL-37
RT-11209H.....	9.....	9TH	45R&47B	FULL-40
RT-11210B.....	10.....	10TH	45R&47B	FULL-40
RT-11509.....	9.....	9TH	45R&47B	FULL-25
RT-11608.....	8.....	8TH	45R&47B	FULL-29
RT-11609A (F).....	9.....	9TH	45R&47B	FULL-25
RT-11609H.....	9.....	9TH	45R&47B	FULL-25
RT-11610 (F).....	10.....	10TH	45R&47B	FULL-25
RT-11613 (F).....	13.....	13TH	45R&47B	FULL-25
RT-11615 (F).....	15.....	15TH	45R&47B	FULL-25
RT-11709H.....	9.....	9TH	45R&47B	FULL-25
RT-11710B.....	10.....	10TH	45R&47B	FULL-25
RT-11715.....	15.....	15TH	45R&47B	FULL-25
RT-12109A-AT (ATE).....	9.....	9TH	45R&47B	FULL-34
RT-12109A-AT (ATE)(ENGINE DRIVEN OPENING).....			66L	FULL-37
RT-12209H.....	9.....	9TH	45R&47B	FULL-40
RT-12210B.....	10.....	10TH	45R&47B	FULL-40
RT-12509.....	9.....	9TH	45R&47B	FULL-25
RT-12510.....	10.....	10TH	45R&47B	FULL-25
RT-12513.....	13.....	13TH	45R&47B	FULL-25
RT-12515.....	15.....	15TH	45R&47B	FULL-25
RT-12609A.....	9.....	9TH	45R&47B	FULL-25
RT-12609H.....	9.....	9TH	45R&47B	FULL-25
RT-12610.....	10.....	10TH	45R&47B	FULL-25
RT-12709H.....	9.....	9TH	45R&47B	FULL-25
RT-12710B (AS2, AS3).....	10.....	10TH	45R&47B	FULL-25
RT-13209H.....	9.....	9TH	45R&47B	FULL-40
RT-13210B.....	10.....	10TH	45R&47B	FULL-40
RT-13609A.....	9.....	9TH	45R&47B	FULL-25
RT-13609H.....	9.....	9TH	45R&47B	FULL-25
RT-13709H.....	9.....	9TH	45R&47B	FULL-25
RT-13710B.....	10.....	10TH	45R&47B	FULL-25
RT-14109A-AT (ATE).....	9.....	9TH	45R&47B	FULL-34
RT-14109A-AT (ATE) (ENGINE DRIVEN OPENING).....			66L	FULL-37
RT-14209H.....	9.....	9TH	45R&47B	FULL-40
RT-14210B.....	10.....	10TH	45R&47B	FULL-40
RT-14608.....	8.....	8TH	45R&47B	FULL-29
RT-14609A.....	9.....	9TH	45R&47B	FULL-25
RT-14609H.....	9.....	9TH	45R&47B	FULL-25
RT-14610.....	10.....	10TH	45R&47B	FULL-25
RT-14613.....	13.....	13TH	45R&47B	FULL-25
RT-14615.....	15.....	15TH	45R&47B	FULL-25
RT-14709H.....	9.....	9TH	45R&47B	FULL-25
RT-14710B (AS2).....	10.....	10TH	45R&47B	FULL-25
RT-14715.....	15.....	15TH	45R&47B	FULL-25
RT-14915.....	15.....	15TH	45R&47B	FULL-25
RT-15613.....	13.....	13TH	45R&47B	FULL-25

## EATON/FULLER (Continued)

RT-15615.....	15.....	15TH	45R&47B	FULL-25
RT-15715.....	15.....	15TH	45R&47B	FULL-25
RT-610.....	10.....	10TH	33R&33B	FULL-13
RT-613.....	13.....	13TH	33R&33B	FULL-13
RT-6609A.....	9.....	9TH	33R&33B	FULL-15
RT-6610.....	10.....	10TH	33R&33B	FULL-13
RT-6613.....	13.....	13TH	33R&33B	FULL-13
RT-7608LL.....	10.....	8TH	33R&33B	FULL-15
RT-7609.....	9.....	9TH	33R&33B	FULL-13
RT-8606L.....	7.....	6TH	45R&47B	FULL-29
RT-8608L.....	9.....	8TH	45R&47B	FULL-29
RT-8609.....	9.....	9TH	33R&33B	FULL-15
RT-8709B.....	9.....	9TH	45R&47B	FULL-25
RT-8908LL.....	10.....	8TH	45R&47B	FULL-25
RT-906.....	6.....	6TH	45R&47B	FULL-25
RT-909A.....	9.....	9TH	45R&47B	FULL-25
RT-910.....	10.....	10TH	45R&47B	FULL-25
RT-9109A-AT.....	9.....	9TH	45R&47B	FULL-34
RT-915.....	15.....	15TH	45R&47B	FULL-25
RT-9508.....	8.....	8TH	45R&47B	FULL-29
RT-9509A.....	9.....	9TH	45R&47B	FULL-25
RT-9513.....	13.....	13TH	45R&47B	FULL-25
RT-9710B.....	10.....	10TH	45R&47B	FULL-25
RTA-14710B-AS.....	10.....	10TH	45R&47B	FULL-25
RTAO-10710B (AC)(AS).....	10.....	9TH	45R&47B	FULL-42
RTAO-10710C (AC)(AS).....	10.....	9TH	45R&47B	FULL-43
RTAO-12710B (AC)(AS).....	10.....	9TH	45R&47B	FULL-42
RTAO-12710C (AC)(AS).....	10.....	9TH	45R&47B	FULL-43
RTAO-14710B (AC)(AS).....	10.....	9TH	45R&47B	FULL-42
RTAO-14710C (AC)(AS).....	10.....	9TH	45R&47B	FULL-43
RTAO-16710B (AC)(AS).....	10.....	9TH	45R&47B	FULL-42
RTAO-16710C (AC)(AS).....	10.....	9TH	45R&47B	FULL-43
RTL-11710B (T2).....	10.....	10TH	45R&47B	FULL-41
RTL-12710B (T2).....	10.....	10TH	45R&47B	FULL-41
RTL-13710B (T2).....	10.....	10TH	45R&47B	FULL-41
RTL-14710B (T2).....	10.....	10TH	45R&47B	FULL-41
RTLC-16609A.....	9.....	9TH	45R&47B	FULL-43
RTLC-16609E.....	9.....	8TH	45R&47B	FULL-43
RTLC-16613A.....	13.....	13TH	45R&47B	FULL-43
RTLC-16613E.....	13.....	13TH	45R&47B	FULL-43
RTLO-11610B (T2).....	10.....	9TH	45R&47B	FULL-41
RTLO-12610B (T2).....	10.....	9TH	45R&47B	FULL-41
RTLO-12613B.....	13.....	12TH	45R&47B	FULL-25
RTLO-12713A.....	13.....	12TH	45R&47B	FULL-30
RTLO-12913A.....	13.....	12TH	45R&47B	FULL-30
RTLO-13118-AMT.....	18.....	17TH	45R&47B	FULL-43
RTLO-13610B (AS).....	10.....	9TH	45R&47B	FULL-25
RTLO-13610B (T2).....	10.....	9TH	45R&47B	FULL-41
RTLO-14610A.....	10.....	9TH	45R&47B	FULL-25
RTLO-14610B (T2).....	10.....	9TH	45R&47B	FULL-41
RTLO-14613A.....	13.....	12TH	45R&47B	FULL-25
RTLO-14613B.....	13.....	12TH	45R&47B	FULL-25
RTLO-14618A.....	18.....	17TH	45R&47B	FULL-25
RTLO-14713A (T2).....	13.....	12TH	45R&47B	FULL-43
RTLO-14718B (T2).....	18.....	17TH	45R&47B	FULL-43
RTLO-14913A (T2).....	13.....	12TH	45R&47B	FULL-30
RTLO-14918A-AS2, AS3.....	18.....	17TH	45R&47B	FULL-43
RTLO-14918B (T2)(AS).....	18.....	17TH	45R&47B	FULL-43
RTLO-15610B (T2).....	10.....	9TH	45R&47B	FULL-41
RTLO-16610B (T2).....	10.....	9TH	45R&47B	FULL-41
RTLO-16618A.....	18.....	17TH	45R&47B	FULL-25
RTLO-16713A (T2).....	13.....	12TH	45R&47B	FULL-43
RTLO-16718B (T2).....	18.....	17TH	45R&47B	FULL-43
RTLO-16913A (T2).....	13.....	12TH	45R&47B	FULL-30



# 2018 TRANSMISSION INDEX

LET. CODE	MAKE MODEL	NO. FWD. SP'DS	DIRECT DRIVE IN.	TEETH IN PTO DRIVER	PTO APPL. NO
-----------	------------	----------------	------------------	---------------------	--------------

## EATON/FULLER (Continued)

RTLO-16913L-DM3.....	13... 11TH	45R&47B	FULL-54
RTLO-16918A-AS2, AS3.....	18... 17TH	45R&47B	FULL-43
RTLO-16918B (T2)(AS).....	18... 17TH	45R&47B	FULL-43
RTLO-17610B (T2).....	10... 9TH	45R&47B	FULL-41
RTLO-18610B (T2).....	10... 9TH	45R&47B	FULL-41
RTLO-18718B.....	18... 17TH	45R&47B	FULL-30
RTLO-18718B (T2).....	18... 17TH	45R&47B	FULL-43
RTLO-18913A (T2).....	13... 12TH	45R&47B	FULL-43
RTLO-18918A-AS2.....	18... 17TH	45R&47B	FULL-43
RTLO-18918B (T2)(AS).....	18... 17TH	45R&47B	FULL-43
RTLO-20718B (T2).....	18... 17TH	45R&47B	FULL-43
RTLO-20913A.....	13... 12TH	45R&47B	FULL-43
RTLO-20918A-AS2, AS3.....	18... 17TH	45R&47B	FULL-43
RTLO-20918B (T2)(AS).....	18... 17TH	45R&47B	FULL-43
RTLO-22918B (AS).....	18... 17TH	45R&47B	FULL-43
RTLO-9118A-MT.....	18... 17TH	45R&47B	FULL-41
RTLQ-16909A (T2).....	9... 8TH	45R&47B	FULL-30
RTLQFC-16909A (T2).....	9... 8TH	45R&47B	FULL-30
RTLQ-16913L-DM3.....	13... 11TH	45R&47B	FULL-54
RTO-10710B (AS2, AS3).....	10... 9TH	45R&47B	FULL-26
RTO-10910B (AS2, AS3).....	10... 9TH	45R&47B	FULL-26
RTO-10910B-DM2.....	10... 9TH	45R&47B	FULL-53
RTO-10910B-DM3.....	10... 9TH	45R&47B	FULL-53
RTO-1110.....	10... 9TH	45R&47B	FULL-27
RTO-11109A-AT (ATE).....	9... 8TH	45R&47B	FULL-35
RTO-11109A-AT (ATE) (ENGINE DRIVEN OPENING).....	66L	FULL-37	
RTO-11109B-AT (ATE).....	9... 8TH	45R&47B	FULL-36
RTO-11109B-AT (ATE) (ENGINE DRIVEN OPENING).....	66L	FULL-37	
RTO-11209B.....	9... 8TH	45R&47B	FULL-39
RTO-11209H.....	9... 8TH	45R&47B	FULL-39
RTO-11210B.....	10... 9TH	45R&47B	FULL-39
RTO-11210C.....	10... 9TH	45R&47B	FULL-38
RTO-11210R.....	10... 9TH	45R&47B	FULL-38
RTO-11509.....	9... 8TH	45R&47B	FULL-26
RTO-1157DL.....	8... 7TH	45R&47B	FULL-21
RTO-1157DLL.....	9... 7TH	45R&47B	FULL-21
RTO-11607L.....	8... 7TH	45R&47B	FULL-22
RTO-11607LL.....	9... 7TH	45R&47B	FULL-22
RTO-11608LL.....	10... 8TH	45R&47B	FULL-26
RTO-11609A.....	9... 8TH	45R&47B	FULL-26
RTO-11609B.....	9... 8TH	45R&47B	FULL-30
RTO-11609H.....	9... 8TH	45R&47B	FULL-30
RTO-11609P.....	9... 8TH	45R&47B	FULL-31
RTO-11609R.....	9... 8TH	45R&47B	FULL-31
RTO-11610.....	10... 9TH	45R&47B	FULL-27
RTO-11613.....	13... 12TH	45R&47B	FULL-25
RTO-11615.....	15... 14TH	45R&47B	FULL-27
RTO-11707DLL.....	9... 7TH	45R&47B	FULL-22
RTO-11707LL.....	9... 7TH	45R&47B	FULL-22
RTO-11708LL.....	10... 8TH	45R&47B	FULL-26
RTO-11709B.....	9... 8TH	45R&47B	FULL-30
RTO-11709H.....	9... 8TH	45R&47B	FULL-30
RTO-11709MMLL.....	9... 8TH	45R&47B	FULL-30
RTO-11710B.....	10... 9TH	45R&47B	FULL-26
RTO-11710C.....	10... 9TH	45R&47B	FULL-30
RTO-11715.....	15... 14TH	45R&47B	FULL-27
RTO-11813.....	13... 12TH	45R&47B	FULL-25
RTO-11908LL.....	10... 8TH	45R&47B	FULL-26
RTO-11909ALL.....	11... 7TH	45R&47B	FULL-30
RTO-11909MMLL.....	11... 7TH	45R&47B	FULL-30
RTO-12109A-AT (ATE).....	9... 8TH	45R&47B	FULL-35
RTO-12109A-AT (ATE) (ENGINE DRIVEN OPENING).....	66L	FULL-37	
RTO-12109B-AT (ATE).....	9... 8TH	45R&47B	FULL-36
RTO-12109B-AT (ATE) (ENGINE DRIVEN OPENING).....	66L	FULL-37	

LET. CODE	MAKE MODEL	NO. FWD. SP'DS	DIRECT DRIVE IN.	TEETH IN PTO DRIVER	PTO APPL. NO
-----------	------------	----------------	------------------	---------------------	--------------

## EATON/FULLER (Continued)

RTO-1213.....	13... 8TH	45R&47B	FULL-25
RTO-12209B.....	9... 8TH	45R&47B	FULL-39
RTO-12209H.....	9... 8TH	45R&47B	FULL-39
RTO-12210B.....	10... 9TH	45R&47B	FULL-39
RTO-12210C.....	10... 9TH	45R&47B	FULL-38
RTO-12210R.....	10... 9TH	45R&47B	FULL-38
RTO-12509.....	9... 8TH	45R&47B	FULL-26
RTO-12510.....	10... 9TH	45R&47B	FULL-27
RTO-12513.....	13... 12TH	45R&47B	FULL-25
RTO-12515.....	15... 14TH	45R&47B	FULL-27
RTO-1258LL.....	10... 8TH	45R&47B	FULL-26
RTO-12609A.....	9... 8TH	45R&47B	FULL-26
RTO-12609B.....	9... 8TH	45R&47B	FULL-30
RTO-12609H.....	9... 8TH	45R&47B	FULL-30
RTO-12609P.....	9... 8TH	45R&47B	FULL-31
RTO-12609R.....	9... 8TH	45R&47B	FULL-31
RTO-12610.....	10... 9TH	45R&47B	FULL-27
RTO-12709H.....	9... 8TH	45R&47B	FULL-30
RTO-12710B (AS2,AS3).....	10... 9TH	45R&47B	FULL-26
RTO-12710C.....	10... 9TH	45R&47B	FULL-30
RTO-12910B (AS2, AS3).....	10... 9TH	45R&47B	FULL-26
RTO-12910B-DM2.....	10... 9TH	45R&47B	FULL-53
RTO-12910B-DM3.....	10... 9TH	45R&47B	FULL-53
RTO-13109A-AT (ATE).....	9... 8TH	45R&47B	FULL-35
RTO-13109A-AT (ATE) (ENGINE DRIVEN OPENING).....	66L	FULL-37	
RTO-13109B-AT (ATE).....	9... 8TH	45R&47B	FULL-36
RTO-13109B-AT (ATE) (ENGINE DRIVEN OPENING).....	66L	FULL-37	
RTO-13209B.....	9... 8TH	45R&47B	FULL-39
RTO-13209H.....	9... 8TH	45R&47B	FULL-39
RTO-13210B.....	10... 9TH	45R&47B	FULL-39
RTO-13210C.....	10... 9TH	45R&47B	FULL-38
RTO-13210R.....	10... 9TH	45R&47B	FULL-38
RTO-13609A.....	9... 8TH	45R&47B	FULL-26
RTO-13609B.....	9... 8TH	45R&47B	FULL-30
RTO-13609H.....	9... 8TH	45R&47B	FULL-30
RTO-13609P.....	9... 8TH	45R&47B	FULL-31
RTO-13609R.....	9... 8TH	45R&47B	FULL-31
RTO-13707DLL.....	9... 7TH	45R&47B	FULL-22
RTO-13707MMLL.....	9... 7TH	45R&47B	FULL-22
RTO-13709H.....	9... 8TH	45R&47B	FULL-30
RTO-13710B.....	10... 9TH	45R&47B	FULL-26
RTO-13710C.....	10... 9TH	45R&47B	FULL-30
RTO-14109A-AT (ATE).....	9... 8TH	45R&47B	FULL-35
RTO-14109A-AT (ATE)(ENGINE DRIVEN OPENING).....	66L	FULL-37	
RTO-14109B-AT (ATE).....	9... 8TH	45R&47B	FULL-36
RTO-14109B-AT (ATE)(ENGINE DRIVEN OPENING).....	66L	FULL-37	
RTO-14209B.....	9... 8TH	45R&47B	FULL-39
RTO-14209H.....	9... 8TH	45R&47B	FULL-39
RTO-14210B.....	10... 9TH	45R&47B	FULL-39
RTO-14210C.....	10... 9TH	45R&47B	FULL-38
RTO-14210R.....	10... 9TH	45R&47B	FULL-38
RTO-14608LL.....	10... 8TH	45R&47B	FULL-26
RTO-14609A.....	9... 8TH	45R&47B	FULL-26
RTO-14609B.....	9... 8TH	45R&47B	FULL-30
RTO-14609H.....	9... 8TH	45R&47B	FULL-30
RTO-14609P.....	9... 8TH	45R&47B	FULL-31
RTO-14609R.....	9... 8TH	45R&47B	FULL-31
RTO-14610.....	10... 9TH	45R&47B	FULL-27
RTO-14610C.....	10... 9TH	45R&47B	FULL-30
RTO-14613.....	13... 12TH	45R&47B	FULL-25
RTO-14615.....	15... 14TH	45R&47B	FULL-27
RTO-14708LL.....	10... 8TH	45R&47B	FULL-26
RTO-14709A.....	9... 8TH	45R&47B	FULL-26
RTO-14709H.....	9... 8TH	45R&47B	FULL-30



# 2018 TRANSMISSION INDEX

LET. CODE	MAKE MODEL	NO. FWD. SP'DS	DIRECT DRIVE IN.	TEETH IN PTO DRIVER	PTO APPL. NO
-----------	------------	----------------	------------------	---------------------	--------------

## EATON/FULLER (Continued)

RTO-14709MLL.....	10.....	9TH	45R&47B	FULL-30
RTO-14710B (AS2, AS3).....	10.....	9TH	45R&47B	FULL-26
RTO-14710C (AS2, AS3).....	10.....	9TH	45R&47B	FULL-30
RTO-14713.....	13.....	12TH	45R&47B	FULL-25
RTO-14715.....	15.....	14TH	45R&47B	FULL-27
RTO-14813.....	13.....	12TH	45R&47B	FULL-25
RTO-14908LL.....	10.....	8TH	45R&47B	FULL-26
RTO-14909ALL.....	11.....	7TH	45R&47B	FULL-30
RTO-14909MLL.....	11.....	7TH	45R&47B	FULL-30
RTO-14910B (AS2, AS3).....	10.....	9TH	45R&47B	FULL-26
RTO-14910B-DM2.....	10.....	9TH	45R&47B	FULL-53
RTO-14910B-DM3.....	10.....	9TH	45R&47B	FULL-53
RTO-14910C (AS2, AS3).....	10.....	9TH	45R&47B	FULL-30
RTO-14915.....	15.....	14TH	45R&47B	FULL-27
RTO-15210B.....	10.....	9TH	45R&47B	FULL-39
RTO-15210C.....	10.....	9TH	45R&47B	FULL-38
RTO-15613.....	13.....	12TH	45R&47B	FULL-25
RTO-15615.....	15.....	14TH	45R&47B	FULL-27
RTO-15618.....	18.....	17TH	45R&47B	FULL-25
RTO-15708LL.....	10.....	8TH	45R&47B	FULL-26
RTO-15710B.....	10.....	9TH	45R&47B	FULL-26
RTO-15710C.....	10.....	9TH	45R&47B	FULL-30
RTO-15715.....	15.....	14TH	45R&47B	FULL-27
RTO-15813.....	13.....	12TH	45R&47B	FULL-25
RTO-16109A-ATE.....	9.....	8TH	45R&47B	FULL-35
RTO-16109A-ATE (ENGINE OPENING).....			66L	FULL-37
RTO-16109B-AT (ATE).....	9.....	8TH	45R&47B	FULL-36
RTO-16109B-AT (ATE) (ENGINE OPENING).....			66L	FULL-37
RTO-16210B.....	10.....	9TH	45R&47B	FULL-39
RTO-16210C.....	10.....	9TH	45R&47B	FULL-38
RTO-16709B.....	9.....	8TH	45R&47B	FULL-30
RTO-16709H.....	9.....	8TH	45R&47B	FULL-30
RTO-16710B (AS2,AS3).....	10.....	9TH	45R&47B	FULL-26
RTO-16710C (AS2, AS3).....	10.....	9TH	45R&47B	FULL-30
RTO-16715.....	15.....	14TH	45R&47B	FULL-27
RTO-16908LL.....	10.....	8TH	45R&47B	FULL-26
RTO-16909ALL.....	11.....	7TH	45R&47B	FULL-30
RTO-16910B (AS2, AS3).....	10.....	9TH	45R&47B	FULL-26
RTO-16910B-DM2.....	10.....	9TH	45R&47B	FULL-53
RTO-16910B-DM3.....	10.....	9TH	45R&47B	FULL-53
RTO-16910C (AS2, AS3).....	10.....	9TH	45R&47B	FULL-30
RTO-16915.....	15.....	14TH	45R&47B	FULL-27
RTO-18910B (AS2, AS3).....	10.....	9TH	45R&47B	FULL-26
RTO-610.....	10.....	9TH	33R&33B	FULL-14
RTO-613.....	13.....	12TH	33R&33B	FULL-14
RTO-6610.....	10.....	9TH	33R&33B	FULL-14
RTO-6613.....	13.....	12TH	33R&33B	FULL-14
RTO-909A.....	9.....	8TH	45R&47B	FULL-26
RTO-910.....	10.....	9TH	45R&47B	FULL-24
RTO-9109A-AT.....	9.....	8TH	45R&47B	FULL-35
RTO-9109B-AT.....	9.....	8TH	45R&47B	FULL-36
RTO-913.....	13.....	12TH	45R&47B	FULL-25
RTO-915.....	15.....	14TH	45R&47B	FULL-24
RTO-9509A.....	9.....	8TH	45R&47B	FULL-26
RTO-9509B.....	9.....	8TH	45R&47B	FULL-30
RTO-9513.....	13.....	12TH	45R&47B	FULL-25
RTO-958LL.....	10.....	8TH	45R&47B	FULL-26
RTOC-16709A.....	9.....	8TH	45R&47B	FULL-43
RTOC-16909A.....	9.....	8TH	45R&47B	FULL-43
RTOC-16913A.....	13.....	12TH	45R&47B	FULL-43
RTOC-18909A.....	9.....	8TH	45R&47B	FULL-43
RTOM-16910B-DM3.....	10.....	9TH	45R&47B	FULL-53
RTOO-11613.....	13.....	10TH	45R&47B	FULL-30
RTOO-14613.....	13.....	10TH	45R&47B	FULL-30

LET. CODE	MAKE MODEL	NO. FWD. SP'DS	DIRECT DRIVE IN.	TEETH IN PTO DRIVER	PTO APPL. NO
-----------	------------	----------------	------------------	---------------------	--------------

## EATON/FULLER (Continued)

RT00-9513.....	13.....	10TH	45R&47B	FULL-30
RTX-11609A.....	9.....	8TH	45R&47B	FULL-26
RTX-11609B.....	9.....	8TH	45R&47B	FULL-30
RTX-11609P.....	9.....	8TH	45R&47B	FULL-31
RTX-11609R.....	9.....	8TH	45R&47B	FULL-31
RTX-11708LL.....	10.....	8TH	45R&47B	FULL-26
RTX-11709H.....	9.....	8TH	45R&47B	FULL-30
RTX-11710B.....	10.....	9TH	45R&47B	FULL-26
RTX-11710C.....	10.....	9TH	45R&47B	FULL-30
RTX-12609B.....	9.....	8TH	45R&47B	FULL-30
RTX-12609P.....	9.....	8TH	45R&47B	FULL-31
RTX-12609R.....	9.....	8TH	45R&47B	FULL-31
RTX-12709H.....	9.....	8TH	45R&47B	FULL-30
RTX-12710B.....	10.....	9TH	45R&47B	FULL-26
RTX-12710C.....	10.....	9TH	45R&47B	FULL-30
RTX-13609B.....	9.....	8TH	45R&47B	FULL-30
RTX-13609P.....	9.....	8TH	45R&47B	FULL-31
RTX-13609R.....	9.....	8TH	45R&47B	FULL-31
RTX-13709H.....	9.....	8TH	45R&47B	FULL-30
RTX-13710B.....	10.....	9TH	45R&47B	FULL-26
RTX-13710C.....	10.....	9TH	45R&47B	FULL-30
RTX-14609A.....	9.....	8TH	45R&47B	FULL-26
RTX-14609B.....	9.....	8TH	45R&47B	FULL-30
RTX-14609P.....	9.....	8TH	45R&47B	FULL-31
RTX-14609R.....	9.....	8TH	45R&47B	FULL-31
RTX-14708LL.....	10.....	8TH	45R&47B	FULL-26
RTX-14709H.....	9.....	8TH	45R&47B	FULL-30
RTX-14710B.....	10.....	9TH	45R&47B	FULL-26
RTX-14710C.....	10.....	9TH	45R&47B	FULL-30
RTX-14715.....	15.....	14TH	45R&47B	FULL-27
RTX-15710B.....	10.....	9TH	45R&47B	FULL-26
RTX-15710C.....	10.....	9TH	45R&47B	FULL-30
RTX-15715.....	15.....	14TH	45R&47B	FULL-27
RTX-16709B.....	9.....	8TH	45R&47B	FULL-30
RTX-16709H.....	9.....	8TH	45R&47B	FULL-30
RTX-16710B.....	10.....	9TH	45R&47B	FULL-26
RTX-16710C.....	10.....	9TH	45R&47B	FULL-30
T-11605A.....	5.....	5TH	45R&47B	FULL-16
T-11605B.....	5.....	5TH	45R&47B	FULL-16
T-11605C.....	5.....	5TH	45R&47B	FULL-19
T-11605D.....	5.....	5TH	45R&47B	FULL-17
T-11605F.....	5.....	5TH	45R&47B	FULL-20
T-11605M.....	5.....	5TH	45R&47B	FULL-17
T-11606.....	6.....	6TH	78R&78B	FULL-28
T-11607A.....	7.....	7TH	78R&78B	FULL-28
T-11607B.....	7.....	7TH	78R&78B	FULL-28
T-14607A.....	7.....	7TH	78R&78B	FULL-32
T-14607B.....	7.....	7TH	78R&78B	FULL-32
T-8607A.....	7.....	7TH	78R&78B	FULL-28
T-8607B.....	7.....	7TH	78R&78B	FULL-28
T-905A.....	5.....	5TH	45R&47B	FULL-16
T-905B.....	5.....	5TH	45R&47B	FULL-16
T-905C.....	5.....	5TH	45R&47B	FULL-19
T-905D.....	5.....	5TH	45R&47B	FULL-17
T-905F.....	5.....	5TH	45R&47B	FULL-20
T-905H.....	5.....	5TH	45R&47B	FULL-16
T-905J.....	5.....	5TH	45R&47B	FULL-19
T-905M.....	5.....	5TH	45R&47B	FULL-17
T-905P.....	5.....	5TH	45R&47B	FULL-16
T-955AL.....	6.....	6TH	45R&47B	FULL-16
T-955ALL.....	7.....	7TH	45R&47B	FULL-16
T-955GL.....	6.....	6TH	45R&47B	FULL-25
TO-11605A.....	5.....	4TH	45R&47B	FULL-22
TO-11605B.....	5.....	4TH	45R&47B	FULL-23





# 2018 TRANSMISSION INDEX

LET. CODE	MAKE MODEL	NO. FWD. SP'DS	DIRECT DRIVE IN.	TEETH IN PTO DRIVER	PTO APPL. NO
-----------	------------	----------------	------------------	---------------------	--------------

## EATON/FULLER (Continued)

TO-11605C.....	5.....	4TH	45R&47B	FULL-18
TO-11605D.....	5.....	4TH	45R&47B	FULL-21
TO-11607B-ASX.....	7.....	6TH	78R&78B	FULL-33
TO-14607B-ASX.....	7.....	6TH	78R&78B	FULL-33
TO-905A.....	5.....	4TH	45R&47B	FULL-21
TO-905B.....	5.....	4TH	45R&47B	FULL-23
TO-905C.....	5.....	4TH	45R&47B	FULL-18
TO-905D.....	5.....	4TH	45R&47B	FULL-21
TO-955AL.....	6.....	5TH	45R&47B	FULL-21
TO-955ALL.....	7.....	6TH	45R&47B	FULL-21
TO-955DLL.....	7.....	6TH	45R&47B	FULL-21
TO-955LL.....	6.....	5TH	45R&47B	FULL-26
TS-11612A.....	12.....	12TH	78R&78B	FULL-28
TS-12612A.....	12.....	12TH	78R&78B	FULL-28
TS-13612A.....	12.....	12TH	78R&78B	FULL-28
TS-15612A.....	12.....	12TH	78R&78B	FULL-28
TS-16612A.....	12.....	12TH	78R&78B	FULL-28
TSO-11612A.....	12.....	11TH	78R&78B	FULL-28
TSO-12612A.....	12.....	11TH	78R&78B	FULL-28
TSO-13612A.....	12.....	11TH	78R&78B	FULL-28
TSO-15612A.....	12.....	11TH	78R&78B	FULL-28
TSO-16612A.....	12.....	11TH	78R&78B	FULL-28
TX-14607B.....	7.....	6TH	78R&78B	FULL-33
TX-8607B.....	7.....	6TH	78R&78B	FULL-33

## FORD

4R100 4X2 (Diesel 1998-2002 Gas 1998-2004).....	4.....	3RD	115L	FORD-01
4R100 4X4(Diesel 1998-2002 Gas 1998-2004).....	4.....	3RD	115L	FORD-02
TORQSHIFT 4X2 (2005 & Later) GAS.....	5.....	4TH	121L	FORD-05
TORQSHIFT 4X2 (2005 & 2010) DIESEL.....	5.....	4TH	121L	FORD-05
TORQSHIFT 4X2 (Diesel 2003-2004).....	5.....	4TH	121L	FORD-03
TORQSHIFT 4X2 2006 LOW CAB FORWARD CHASSIS.....	5.....	4TH	121L	FORD-07
TORQSHIFT 4X2 and 4X4 (Diesel 2003-2004).....	5.....	4TH	121L	FORD-04
TORQSHIFT 4X2 OR 4X4 (2005 & Later GAS).....	5.....	4TH	121L	FORD-06
(2005-2010 DIESEL).....	5.....	4TH	121L	FORD-06
TORQSHIFT 4X4 (2005 & Later GAS).....	5.....	4TH	121L	FORD-06
(2005-2010 DIESEL).....	5.....	4TH	121L	FORD-06
TORQSHIFT 6R140 Diesel (2011&LATER DIESEL) F-250 - F-550 ONLY.....	6.....	4TH	52L	FORD-08
TORQSHIFT 6R140 6.8L GAS(2011&LATER F-650) 2016 & LATER F-750) F-650.....	6.....	4TH	52L	FORD-09
TORQSHIFT 6R140 (2016 & LATER GAS OR DIESEL) F-650/F-750.....	6.....	4TH	52L	FORD-10
TORQSHIFT 6R140 (JAN 6, 2016 & LATER DIESEL ONLY) F-650/F-750.....	6.....	4TH	52L	FORD-11

## GETRAG

360.....	5.....	4TH	33R&33L	GETR-01
----------	--------	-----	---------	---------

## HINO

LF05S.....	5.....	5TH		HINO-02
LF06S.....	6.....	6TH		HINO-03
LJ06S.....	6.....	6TH		HINO-04
M550.....	6.....	6TH		HINO-05
MF06S.....	6.....	6TH		HINO-01

LET. CODE	MAKE MODEL	NO. FWD. SP'DS	DIRECT DRIVE IN.	TEETH IN PTO DRIVER	PTO APPL. NO
-----------	------------	----------------	------------------	---------------------	--------------

## INTERNATIONAL

13289 FULLER T-14607B.....	7.....	7TH	78R&78B	FULL-32
13447 SPICER PSO140-6A.....	6.....	5TH	54R&54B	SPCR-39
13ADK FORD TORQSHIFT.....	5.....	4TH	121L	FORD-07
13ADL FORD TORQSHIFT.....	5.....	4TH	121L	FORD-07
13ADN ALLISON 3000 EVS.....	5.....	4TH	68R&68L	ALLI-05
13ADP ALLISON 3500 EVS.....	6.....	4TH	68R&68L	ALLI-05
13ADR ALLISON 3500 EVS.....	5.....	4TH	68R&68L	ALLI-05
13ADX ALLISON 3000 TRV.....	6.....	4TH	68R&68L	ALLI-05
13ADY ALLISON 3000 TRV.....	5.....	4TH	68R&68L	ALLI-05
13AEC ALLISON 1000 HS.....	5.....	4TH	NONE	N1
13AED ALLISON 2100 HS.....	5.....	4TH	NONE	N1
13AEE ALLISON 2200 HS.....	5.....	4TH	NONE	N1
13AEP ALLISON 1000 PTS.....	5.....	4TH	NONE	N1
13AER ALLISON 2100 PTS.....	5.....	4TH	NONE	N1
13AES ALLISON 2200 PTS.....	5.....	4TH	NONE	N1
13AET ALLISON 2500 PTS.....	5.....	4TH	NONE	N1
13AEU ALLISON 3000 PTS.....	6.....	5TH	NONE	N1
13AEV ALLISON 3000 PTS.....	6.....	5TH	NONE	N1
13AEW ALLISON 2100 EVS.....	5.....	4TH	64R&64L	ALLI-09
13AEX ALLISON 2200 EVS.....	5.....	4TH	64R&64L	ALLI-09
13AEY ALLISON 2500 EVS.....	5.....	4TH	64R&64L	ALLI-09
13AEZ ALLISON 2100 RDS.....	5.....	4TH	64R&64L	ALLI-09
13AGA ALLISON 2200 RDS.....	5.....	4TH	64R&64L	ALLI-09
13AGB ALLISON 2500 RDS.....	5.....	4TH	64R&64L	ALLI-09
13AGC ALLISON 2500 RDS.....	5.....	4TH	64R&64L	ALLI-09
13AGD ALLISON 3000 RDS.....	5.....	4TH	68R&68L	ALLI-05
13AGE ALLISON 3000 RDS.....	5.....	4TH	68R&68L	ALLI-05
13AGH ALLISON 3000 RDS.....	6.....	4TH	68R&68L	ALLI-05
13AGJ ALLISON 3000 RDS.....	6.....	4TH	68R&68L	ALLI-05
13AGL ALLISON 3500 RDS.....	5.....	4TH	68R&68L	ALLI-05
13AGM ALLISON 3500 RDS.....	5.....	4TH	68R&68L	ALLI-05
13AGP ALLISON 3500 RDS.....	6.....	4TH	68R&68L	ALLI-05
13AGR ALLISON 3500 RDS.....	6.....	4TH	68R&68L	ALLI-05
13AHE ALLISON 1000 HS.....	5.....	4TH	NONE	N1
13AHH ALLISON 2200 HS.....	5.....	4TH	NONE	N1
13AHK ALLISON 1000 PTS.....	5.....	4TH	NONE	N1
13AHL ALLISON 2100 PTS.....	5.....	4TH	NONE	N1
13AHM ALLISON 2200 PTS.....	5.....	4TH	NONE	N1
13AHN ALLISON 2500 PTS.....	5.....	4TH	NONE	N1
13AHP ALLISON 2100 RDS.....	5.....	4TH	64R&64L	ALLI-09
13AHR ALLISON 2200 RDS.....	5.....	4TH	64R&64L	ALLI-09
13AHS ALLISON 2500 RDS.....	5.....	4TH	64R&64L	ALLI-09
13AHT ALLISON 2500 RDS.....	5.....	4TH	64R&64L	ALLI-09
13AHU ALLISON 2100 EVS.....	5.....	4TH	64R&64L	ALLI-09
13AHV ALLISON 2200 EVS.....	5.....	4TH	64R&64L	ALLI-09
13AHW ALLISON 2500 EVS.....	5.....	4TH	64R&64L	ALLI-09
13AJB ALLISON 3000 PTS.....	6.....	5TH	NONE	N1
13AJC ALLISON 3000 PTS.....	6.....	5TH	NONE	N1
13AJE ALLISON 3000 RDS.....	5.....	4TH	68R&68L	ALLI-05
13AJG ALLISON 3000 RDS.....	5.....	4TH	68R&68L	ALLI-05
13AJH ALLISON 3000 RDS.....	6.....	4TH	68R&68L	ALLI-05
13AJJ ALLISON 3000 RDS.....	6.....	4TH	68R&68L	ALLI-05
13AJK ALLISON 3500 RDS.....	5.....	4TH	68R&68L	ALLI-05
13AJL ALLISON 3500 RDS.....	5.....	4TH	68R&68L	ALLI-05
13AJN ALLISON 3500 RDS.....	6.....	4TH	68R&68L	ALLI-05
13AJP ALLISON 3500 RDS.....	6.....	4TH	68R&68L	ALLI-05
13AJR ALLISON B-300.....	6.....	5TH	NONE	N1
13AJU ALLISON 3000 EVS.....	6.....	4TH	68R&68L	ALLI-05
13AJV ALLISON 3000 EVS.....	5.....	4TH	68R&68L	ALLI-05
13AJW ALLISON 3500 EVS.....	6.....	4TH	68R&68L	ALLI-05

### Notes:

N1 – No PTOs Available.



# 2018 TRANSMISSION INDEX

LET. CODE	MAKE MODEL	NO. FWD. SP'DS	DIRECT DRIVE IN.	TEETH IN PTO DRIVER	PTO APPL. NO
-----------	------------	----------------	------------------	---------------------	--------------

## INTERNATIONAL (Continued)

13AJX ALLISON 3500 EVS.....	5.....	4TH	68R&68L	ALLI-05
13AKA ALLISON 3000 TRV.....	6.....	4TH	68R&68L	ALLI-05
13AKB ALLISON 3000 TRV.....	5.....	4TH	68R&68L	ALLI-05
13AKG ALLISON 4000 HS.....	5.....	4TH	NONE	N1
13AKV ALLISON 1000 RDS.....	5.....	4TH	64R&64L	ALLI-09
13AKW ALLISON 1000 EVS.....	5.....	4TH	64R&64L	ALLI-09
13AKX ALLISON 1000 RDS.....	5.....	4TH	64R&64L	ALLI-09
13AKY ALLISON 1000 EVS.....	5.....	4TH	64R&64L	ALLI-09
13DBG SPICER PS110-7B.....	7.....	7TH	56R&56B	SPCR-35
13DBH SPICER PS145-7A.....	7.....	7TH	43R&43B	SPCR-34
13DBJ SPICER PS110-7A.....	7.....	7TH	43R&43B	SPCR-34
13DDS SPICER PSO115-10V.....	10.....	9TH	45R&45B	SPCR-45
13DGT SPICER ES46-5A.....	5.....	5TH	32R&32L	SPCR-55
13DGU SPICER ES56-5A.....	5.....	5TH	32R&32L	SPCR-55
13GAH FULLER FR-15210B.....	10.....	10TH	45R&47B	FULL-40
13GEW FULLER FS-6305A.....	5.....	5TH	39R&39L	FULL-11
13GGK FULLER FR-11210B.....	10.....	9TH	45R&47B	FULL-40
13GGL FULLER FRO-11210B.....	10.....	9TH	45R&47B	FULL-39
13GGM FULLER FRO-11210C.....	10.....	9TH	45R&47B	FULL-38
13GGT FULLER FR-12210B.....	10.....	9TH	45R&47B	FULL-40
13GGU FULLER FRO-12210B.....	10.....	9TH	45R&47B	FULL-39
13GGV FULLER FRO-12210C.....	10.....	9TH	45R&47B	FULL-38
13GHA FULLER FR-13210B.....	10.....	9TH	45R&47B	FULL-40
13GHB FULLER FRO-13210B.....	10.....	9TH	45R&47B	FULL-39
13GHC FULLER FRO-13210C.....	10.....	9TH	45R&47B	FULL-38
13GHJ FULLER FR-14210B.....	10.....	9TH	45R&47B	FULL-40
13GHK FULLER FRO-14210B.....	10.....	9TH	45R&47B	FULL-39
13GHL FULLER FRO-14210C.....	10.....	9TH	45R&47B	FULL-38
13GHN FULLER FRO-15210B.....	10.....	9TH	45R&47B	FULL-39
13GHP FULLER FRO-15210C.....	10.....	9TH	45R&47B	FULL-38
13GHR FULLER FRO-16210B.....	10.....	9TH	45R&47B	FULL-39
13GHS FULLER FRO-16210C.....	10.....	9TH	45R&47B	FULL-38
13GHV FULLER RTO-11908LL.....	10.....	8TH	45R&47B	FULL-26
13GHW FULLER RTO-14908LL.....	10.....	8TH	45R&47B	FULL-26
13GHX FULLER RTO-16908LL.....	10.....	8TH	45R&47B	FULL-26
13GHY FULLER RTO-16915.....	15.....	14TH	45R&47B	FULL-27
13GJR FULLER RT-8908LL.....	10.....	8TH	45R&47B	FULL-25
13GJS FULLER RTLO-18913A.....	13.....	12TH	45R&47B	FULL-43
13GJT FULLER FR-9210B.....	10.....	9TH	45R&47B	FULL-39
13GKJ FULLER RTLO-16913A.....	13.....	12TH	45R&47B	FULL-30
13GKK FULLER RTLO-14918B.....	18.....	17TH	45R&47B	FULL-43
13GKL FULLER RTLO-16918B.....	18.....	17TH	45R&47B	FULL-43
13GKM FULLER RTLO-18918B.....	18.....	17TH	45R&47B	FULL-43
13GKZ FULLER FRO-18210C.....	10.....	9TH	45R&47B	FULL-38
13GMJ FULLER FSO-8406A.....	6.....	5TH	48R&48L	FULL-49
13GML FULLER FRLO-14410C-T2.....	10.....	9TH	51R&51L	FULL-50
13GMM FULLER FRLO-15410C-T2.....	10.....	9TH	51R&51L	FULL-50
13GMN FULLER FRLO-16410C-T2.....	10.....	9TH	51R&51L	FULL-50
13GMS FULLER FS-6406N.....	6.....	6TH	39R&39L	FULL-52
13GMY FULLER RTO(F)-11909ALL.....	11.....	7TH	45R&47B	FULL-30
13GMZ FULLER RTO(F)-14909ALL.....	11.....	7TH	45R&47B	FULL-30
13GNA FULLER RTO(F)-16909ALL.....	11.....	7TH	45R&47B	FULL-30
13GNG FULLER FS-5406N.....	6.....	6TH	39R&39L	FULL-52
13GNM FULLER RTLOF-20918B.....	18.....	17TH	45R&47B	FULL-43
13GNU FULLER RTO-16910C-AS2.....	10.....	9TH	45R&47B	FULL-30
13GPB FULLER FRLOF-15410C.....	10.....	9TH	51R&51L	FULL-50
13GPC FULLER FRLOF-16410C.....	10.....	9TH	51R&51L	FULL-50
13GPD FULLER FRLOF-14410C.....	10.....	9TH	51R&51L	FULL-50
13GPL FULLER RTOC-16909A.....	9.....	8TH	45R&47B	FULL-41
13GPM FULLER RTO-16910B-DM3.....	10.....	9TH	45R&47B	FULL-53
13GPN FULLER RTO-14910B-AS3.....	10.....	9TH	45R&47B	FULL-26
13GPP FULLER RTO-14910C-AS3.....	10.....	9TH	45R&47B	FULL-30
13GPR FULLER RTO-16910B-AS3.....	10.....	9TH	45R&47B	FULL-26

LET. CODE	MAKE MODEL	NO. FWD. SP'DS	DIRECT DRIVE IN.	TEETH IN PTO DRIVER	PTO APPL. NO
-----------	------------	----------------	------------------	---------------------	--------------

## INTERNATIONAL (Continued)

13GPS FULLER RTO-16910C-AS3.....	10.....	9TH	45R&47B	FULL-30
13GPT FULLER RTLO-16918A-AS3.....	18.....	16TH	45R&47B	FULL-43
13GPU FULLER RTLO-18918A-AS3 AUTOSHIFT.....	18.....	16TH	45R&47B	FULL-43
13GPW FULLER RTO-14910B-DM3.....	10.....	9TH	45R&47B	FULL-53
13GRD FULLER RTLO(F)-12913A.....	13.....	12TH	45R&47B	FULL-30
13GRE FULLER RTLO(F)-14913A.....	13.....	12TH	45R&47B	FULL-30
13GRH FULLER RTLOC-16909A-T2.....	9.....	8TH	45R&47B	FULL-30
13GRK FULLER RTO-12910B-AS3.....	10.....	9TH	45R&47B	FULL-26
13GRL FULLER RTO-12910B-DM3.....	10.....	9TH	45R&47B	FULL-53
13MCG SPICER ESO66-7B.....	7.....	6TH	34R&34L	SPCR-29
13MCH SPICER ES56-7B (301739).....	7.....	7TH	34R&34L	SPCR-56
13MET MERITOR M-13G10A-M13.....	10.....	10TH	45R&45B	MERT-01
13MEU MERITOR M-14G10A-M14.....	10.....	10TH	45R&45B	MERT-01
13MEV MERITOR M-15G10A-M15.....	10.....	10TH	45R&45B	MERT-01
13MEX MERITOR MO-12G10A-M12.....	10.....	9TH	45R&45B	MERT-02
13MEY MERITOR MO-13G10A-M13.....	10.....	9TH	45R&45B	MERT-02
13MEZ MERITOR MO-14G10A-M14.....	10.....	9TH	45R&45B	MERT-02
13MGA MERITOR MO-15G10A-M15.....	10.....	9TH	45R&45B	MERT-02
13MGB MERITOR MO-16G10A-M16.....	10.....	9TH	45R&45B	MERT-02
13MGG MERITOR MO-14G10C-M14.....	10.....	9TH	45R&45B	MERT-04
13MGH MERITOR MO-15G10C-M15.....	10.....	9TH	45R&45B	MERT-04
13MGJ MERITOR MO-16G10C-M16.....	10.....	9TH	45R&45B	MERT-04
13MGM MERITOR MO-14G10C-M16.....	10.....	9TH	45R&45B	MERT-04
13MGN MERITOR MO-16G10C-M18.....	10.....	9TH	45R&45B	MERT-04
13MGV ZF MO-14Z12A-A14.....	12.....	11TH	-	MERT-05
13MGW ZF MO-16Z12A-A16.....	12.....	11TH	-	MERT-05
T-17 NEW PROCESS 435L.....	4.....	4TH	35R	NEWP-05
T-18 NEW PROCESS 435L.....	4.....	4TH	35L	NEWP-05
T-20 NEW PROCESS 435L.....	4.....	4TH	35R&35L	NEWP-05

## ISUZU

ELECTROMATIC (JATCO).....	4.....	3RD	63L	JATC-01
MBG-5A.....	5.....	5TH	34L	ISUZ-01
MBG-5B.....	5.....	5TH	35L	ISUZ-02
MBG-5F.....	5.....	5TH	37L	ISUZ-03
MBG-5H.....	5.....	5TH	35L	ISUZ-02
MBP-6P.....	6.....	6TH	34L	ISUZ-13
MBP-6Q.....	6.....	6TH	35L	ISUZ-14
MJA-7U.....	7.....	7TH		ISUZ-18
MLD-6F.....	6.....	6TH	35L	ISUZ-08
MLD-6Q.....	6.....	6TH	36L	ISUZ-09
MYY-5T.....	5.....	5TH		ISUZ-16
MYY-6P.....	6.....	6TH		ISUZ-16
MZZ-6F.....	6.....	6TH		ISUZ-17
MZZ-6U.....	6.....	6TH	37L	ISUZ-15

### Notes:

N1 - No PTOs Available.

## JATCO

AUTOMATIC.....	4.....	3RD	63L	JATC-01
----------------	--------	-----	-----	---------



# 2018 TRANSMISSION INDEX

LET. CODE	MAKE MODEL	NO. FWD. SP'DS	DIRECT DRIVE IN.	TEETH IN PTO DRIVER	PTO APPL. NO
-----------	------------	----------------	------------------	---------------------	--------------

LET. CODE	MAKE MODEL	NO. FWD. SP'DS	DIRECT DRIVE IN.	TEETH IN PTO DRIVER	PTO APPL. NO
-----------	------------	----------------	------------------	---------------------	--------------

## MACK

There are many older model Mack transmissions not listed here for which Muncie can provide PTOs. Contact the Muncie Sales Department for assistance with these models. (Includes TRQ-7220, TRD-720, TRDL-7220, TRD-67, TRQ-720, ect.) Obtain gear tooth count prior to calling Muncie. Transmission models can be verified by use of the 11KBA\*\*\*\*\* number located on the transmission.

1078.....	5.....	5TH	34R&34L	MACK-01
4106A (EATON) (MIDLINER).....	6.....	6TH	45R	EATN-03
4106-B (EATON) (MIDLINER).....	6.....	6TH	43R	EATN-01
T-105 (RENAULT G405-1).....	5.....	5TH	37R	RENA-01
T-1050 (BDSL-2152).....	5.....	5TH	46R	N2
T-105A (RENAULT G405-0).....	5.....	5TH	37R	RENA-02
T-1060 (BDSL-181, 2052R).....	6.....	6TH	33R	N4
T-1060A (RENAULT G406-0).....	6.....	5TH	37R	RENA-02
T-1060B (RENAULT G406-1).....				N2
T-1070.....	12.....	11TH	37R&37L	MACK-04
T-1070B.....	12.....	11TH	37R&37L	MACK-04
T-1090.....	9.....	7TH	53R	RENA-03
T-1100 (BDSL-2142, 2142R).....	10.....	10TH	53R	RENA-04
T2050.....	5.....	5TH	54R&54L	MACK-05
T2060.....	6.....	6TH	54R&54L	MACK-05
T2060A.....	6.....	6TH	40R&40L	MACK-11
T2060C.....	6.....	4TH	48R&48L	MACK-10
T2070 (FRONT BOX).....	7.....	7TH	54R&54L	MACK-05
T2070 (REAR BOX).....	7.....	7TH	49R&49L	MACK-06
T2070B (FRONT BOX).....	7.....	7TH	54R&54L	MACK-05
T2070B (REAR BOX).....	7.....	7TH	49R&49L	MACK-06
T2070C (FRONT BOX).....	7.....	4TH	48R&48L	MACK-10
T2070C (REAR BOX).....	7.....	7TH	49R&49L	MACK-06
T2070D (FRONT BOX).....	7.....	7TH	48R&48L	MACK-10
T2070D (REAR BOX).....	7.....	7TH	49R&49L	MACK-06
T2070F.....	7.....	7TH	54R&54L	MACK-05
T2080.....	8.....	8TH	54R&54L	MACK-05
T2080B.....	8.....	8TH	54R&54L	MACK-05
T2080B (REAR BOX).....	8.....	8TH	49R&49L	MACK-06
T2080C.....	8.....	4TH	48R&48L	MACK-10
T2080D (FRONT BOX).....	8.....	8TH	48R&48L	MACK-10
T2080D (REAR BOX).....	8.....	8TH	49R&49L	MACK-06
T2090.....	9.....	9TH	54R&54L	MACK-07
T2100.....	10.....	10TH	54R&54L	MACK-08
T2110B (FRONT BOX).....	10.....	10TH	54R&54L	MACK-08
T2110B (REAR BOX).....	10.....	10TH	49R&49L	MACK-12
T2130 (FRONT BOX).....	13.....	13TH	54R&54L	MACK-07
T2130 (REAR BOX).....	13.....	13TH	49R&49L	MACK-09
T2130B (FRONT BOX).....	13.....	13TH	54R&54L	MACK-07
T2130B (REAR BOX).....	13.....	13TH	49R&49L	MACK-09
T2180 (FRONT BOX).....	18.....	18TH	54R&54L	MACK-07
T2180 (REAR BOX).....	18.....	18TH	49R&49L	MACK-09
T2180B (FRONT BOX).....	18.....	18TH	54R&54L	MACK-07
T2180B (REAR BOX).....	18.....	18TH	49R&49L	MACK-09
T305.....	5.....	5TH	54R&54L	MACK-05
T306.....	6.....	6TH	54R&54L	MACK-05
T306G.....	6.....	6TH	40R&40L	MACK-11
T307 (FRONT BOX).....	7.....	7TH	54R&54L	MACK-05
T307 (REAR BOX).....	7.....	7TH	49R&49L	MACK-06
T307M (FRONT BOX).....	7.....	7TH	54R&54L	MACK-05
T307M (REAR BOX).....	7.....	7TH	49R&49L	MACK-06
T308.....	8.....	8TH	54R&54L	MACK-05
T308M (FRONT BOX).....	8.....	8TH	54R&54L	MACK-05
T308M (REAR BOX).....	8.....	8TH	49R&49L	MACK-06
T309.....	9.....	9TH	54R&54L	MACK-07
T309L.....	9.....	9TH	54R&54L	MACK-07
T309LR.....	9.....	9TH	54R&54L	MACK-07

## MACK (Continued)

T310.....	10.....	8TH	53R&53L	MACK-13
T310M (FRONT BOX).....	10.....	8TH	53R&53L	MACK-13
T310M (REAR BOX).....	10.....	8TH	49R&49L	MACK-15
T310ME (21) (FRONT BOX).....	10.....	8TH	53R&53L	MACK-13
T310ME (21) (REAR BOX).....	10.....	8TH	49R&49L	MACK-15
T310MLR (FRONT BOX).....	10.....	8TH	54R&54L	MACK-07
T310MLR (REAR BOX).....	10.....	8TH	49R&49L	MACK-15
T313 (FRONT BOX).....	13.....	11TH	54R&54L	MACK-07
T31321 (FRONT BOX).....	13.....	11TH	54R&54L	MACK-07
T313L (FRONT BOX).....	13.....	11TH	54R&54L	MACK-07
T313L (REAR BOX).....	13.....	11TH	49R&49L	MACK-14
T313L21 (FRONT BOX).....	13.....	11TH	54R&54L	MACK-07
T313L21 (REAR BOX).....	13.....	11TH	49R&49L	MACK-14
T313LR (FRONT BOX).....	13.....	11TH	54R&54L	MACK-07
T313LR (REAR BOX).....	13.....	11TH	49R&49L	MACK-14
T313LR21 (FRONT BOX).....	13.....	11TH	54R&54L	MACK-07
T313LR21 (REAR BOX).....	13.....	11TH	49R&49L	MACK-14
T318 (FRONT BOX).....	18.....	16TH	54R&54L	MACK-07
T31821 (FRONT BOX).....	18.....	16TH	54R&54L	MACK-07
T318L (FRONT BOX).....	18.....	16TH	54R&54L	MACK-07
T318L (REAR BOX).....	18.....	16TH	49R&49L	MACK-14
T318L21 (FRONT BOX).....	18.....	16TH	54R&54L	MACK-07
T318L21 (REAR BOX).....	18.....	16TH	49R&49L	MACK-14
T318LR (FRONT BOX).....	18.....	16TH	54R&54L	MACK-07
T318LR (REAR BOX).....	18.....	16TH	49R&49L	MACK-14
T318LR21 (FRONT BOX).....	18.....	16TH	54R&54L	MACK-07
T318LR21 (REAR BOX).....	18.....	16TH	49R&49L	MACK-14
TM308.....	8.....	7TH	54R&54L	MACK-16
TM308M (FRONT BOX).....	8.....	7TH	54R&54L	MACK-07
TM308M (REAR BOX).....	8.....	7TH	49R&49L	MACK-17
TM309.....	9.....	8TH	54R&54L	MACK-16
TM309M (FRONT BOX).....	9.....	8TH	54R&54L	MACK-07
TM309M (REAR BOX).....	9.....	8TH	49R&49L	MACK-17
TMD12AD.....	12.....	12TH		VOLV-04
TMD12AO.....	12.....	11TH		VOLV-05
TR-7220.....	5.....	4TH	25R&25L	N3
TRD-720.....	10.....	4TH	25R&25L	N3
TRD-7220.....	10.....	4TH	25R&25L	N3
TRD-72250.....	10.....	4TH	25R&25L	N3
TRD-7250.....	10.....	4TH	25R&25L	N3
TRDL-107.....	10.....	10TH	37R&37L	MACK-02
TRDL-1070.....	10.....	9TH	37R&37L	MACK-04
TRDL-720.....	10.....	4TH	25R&25L	N3
TRDL-7220.....	10.....	4TH	25R&25L	N3
TRDL-72250.....	10.....	4TH	25R&25L	N3
TRDL-7250.....	10.....	4TH	25R&25L	N3
TRDLG-1070.....	7.....	6TH	37R&37L	MACK-04
TRDX-720.....	10.....	4TH	25R&25L	N3
TRDX-7220.....	10.....	4TH	25R&25L	N3
TRDXL-107.....	6.....	6TH	34R&34L	MACK-01
TRDXL-1070.....	6.....	5TH	34R&34L	MACK-01
TRDXL-1071.....	7.....	6TH	34R&34L	MACK-01
TRDXL-1078.....	6.....	6TH	34R&34L	MACK-01
TRDXL-10780.....	6.....	5TH	34R&34L	MACK-01
TRDXL-10781.....	7.....	6TH	34R&34L	MACK-01
TRDXT-720.....	10.....	4TH	25R&25L	N3
TRDXT-7220.....	10.....	4TH	25R&25L	N3
TRL-107.....	5.....	5TH	34R&34L	MACK-01
TRL-1076.....	5.....	5TH	34R&34L	MACK-01

### Notes:

N2 – Not Current Production Transmission – No Muncie PTO.

N3 – PTO Application Available From M-Power or Muncie Website.

N4 – Not Current Production Trans. – Contact Muncie for Application Info.



# 2018 TRANSMISSION INDEX

LET. CODE	MAKE MODEL	NO. FWD. SP'DS	DIRECT DRIVE IN.	TEETH IN PTO DRIVER	PTO APPL. NO
-----------	------------	----------------	------------------	---------------------	--------------

## MACK (Continued)

TRL-1078		5	5TH	34R&34L	MACK-01
TRQ-720		20	5TH	25R&25L	N3
TRQ-7210		20	5TH	25R&25L	N3
TRQ-7220		20	5TH	25R&25L	N3
TRT-720		15	4TH	25R&25L	N3
TRT-7220		15	4TH	25R&25L	N3
TRTL-720		15	4TH	25R&25L	N3
TRTL-7220		15	4TH	25R&25L	N3
TRTQ-7220		20	5TH	25R&25L	N3
TRTXL-107		12	12TH	37R&37L	MACK-02
TRTXL-1070		12	11TH	37R&37L	MACK-04
TRTXL-1070B		12	11TH	37R&37L	MACK-04
TRX-107		6	6TH	37R&37L	MACK-02
TRXL-107		6	6TH	37R&37L	MACK-02
TRXL-1070		5	4TH	37R&37L	MACK-03
TRXL-1070A		5	4TH	37R&37L	MACK-03
TRXL-1071		6	6TH	37R&37L	MACK-02
TRXL-10710		5	4TH	37R&37L	MACK-03
TRXL-1071A		6	6TH	37R&37L	MACK-02
TRXL-1078		6	6TH	37R&37L	MACK-02
TRXL-107A		6	6TH	37R&37L	MACK-02
X-107		6	6TH	37R&37L	MACK-02
X-1070		5	4TH	37R&37L	MACK-03
X-1071		6	6TH	37R&37L	MACK-02
X-107A		6	6TH	37R&37L	MACK-02

## MERCEDES

G56 DODGE RAM MANUAL		6	5TH	52R&52L	MERC-03
G56-6		6	5TH	52R&52L	MERC-03
G60-6		6	6TH	45R	MERC-05
G85-6		6	5TH	53R	MERC-05
MBT520-6DA (Automated)		6	6TH	45R	MERC-01
MBT520S-6D (BM 715.053)		6	6TH	45R	MERC-01
MBT660-60A (Automated)		6	5TH	53R	MERC-02
MBT660S-60 (BM 715.062)		6	5TH	53R	MERC-02
AGS (G85 712.631)		6	5TH	53R	MERC-02
TDET-0880		5	4TH	33L	TREM-02
TDET-2196		5	4TH	33L	TREM-02

## MITSUBISHI

M030A4 AUTOMATIC		4	3RD	63L	JATC-01
M035A4		4	3RD	58L	AISN-01
M035S5		5	5TH	35L	MIT5-03
M036A6		6	5TH	69L	AISN-02
M036S5 (4x2 Only)		5	4TH	40L	MIT5-07
M036S6 (4x2 Only)		6	5TH	40L	MIT5-07
M038S6 DUONIC		6	5TH	44L	MIT5-08
M050S5		5	5TH	35L	MIT5-04
M050S6-OD		6	5TH	35L	MIT5-04
M060S5		5	5TH	35L	MIT5-05
M060S6-D		6	6TH	41L	MIT5-06
M060S6-OD		6	5TH	35L	MIT5-05
M060S9 (EATON FS-8209A)		9	9TH	23L	EATN-02
M070S6-D		6	6TH	41L	MIT5-06
M3 (S5)		5	5TH		N4
M4 (S5)		5	5TH	37L	MIT5-01
M5 (S5)		5	5TH	37L	MIT5-01
M6 (S5)		5	5TH	37L	MIT5-01
M8S2X5 Before 4/94		10	10TH	29L	MIT5-02
MY-600		6	5TH	69L	AISN-02

LET. CODE	MAKE MODEL	NO. FWD. SP'DS	DIRECT DRIVE IN.	TEETH IN PTO DRIVER	PTO APPL. NO
-----------	------------	----------------	------------------	---------------------	--------------

## MUNCIE

SS66-U2 (SPLITSHAFT)		1		23R&23L	MUNC-01
SS88 (SPLITSHAFT)		1		50R&50L	MUNC-02

## NEW PROCESS

203 TRANSFER CASE		2	2ND	32R&32L	N4
205 TRANSFER CASE		2	2ND	35L	NEWP-01
435DE (6.68 LOW)		4	4TH	34R&34L	NEWP-03
435DL (6.68 Low)(Ford Before 1979)(Dodge Before 1986)		4	4TH	35R&35L	NEWP-05
435FE (6.68 LOW)(FORD)		4	4TH	34R	NEWP-04
435FL (6.68 Low)(Ford Before 1979)(Dodge Before 1986)		4	4TH	35R&35L	NEWP-05
435GL (6.68 Low)(Ford Before 1979)(Dodge Before 1986)		4	4TH	35R&35L	NEWP-05
540		5	5TH	20R&15L	N3
540C		5	5TH	20R&15L	N3
540CD		5	5TH	20R&15L	N3
540DD		5	5TH	20R&15L	N3
540FD		5	5TH	20R&15L	N3
540GD		5	5TH	20R&15L	N3
540R		5	5TH	20R&15L	N3
540T		5	5TH	20R&15L	N3
540W		5	5TH	20R&15L	N3
542CD (6.15 LOW) (6.29 LOW)		5	5TH	20R&23L	NEWP-06
542CL (7.24 LOW) (7.33 LOW)		5	5TH	20R&23L	NEWP-07
542DD (6.15 LOW) (6.29 LOW)		5	5TH	20R&23L	NEWP-06
542DL (7.24 LOW) (7.33 LOW)		5	5TH	19R&23L	NEWP-08
542FD (6.15 LOW) (6.29 LOW)		5	5TH	20R&23L	NEWP-06
542FL (7.24 LOW) (7.33 LOW)		5	5TH	19R&23L	NEWP-08
542GD (6.15 LOW) (6.29 LOW)		5	5TH	20R&23L	NEWP-06
542GL (7.24 LOW) (7.33 LOW)		5	5TH	20R&23L	NEWP-07

## NEW VENTURE

241HD TRANSFER CASE		2	2ND	38R	NEWV-03
NV021				38R	NEWV-04
NV-4500 (5.61 LOW-DODGE)		5	4TH	30R&30L	NEWV-01
NV-4500 (5.61-LOW CHEVY) (AFTER BUILD DATE 021794)		5	4TH	30R&30L	NEWV-01
NV-4500 (5.61-LOW GM 2001 3600 USE CHEV-2)		5	4TH	30R&30L	NEWV-01
NV-4500 (6.34 LOW-CHEVY) (BEFORE BUILD DATE 021794)		5	4TH	32R&32L	NEWV-02
NV-4500HD (DODGE)		5	4TH	30R&30L	NEWV-01
NV-5600		6	5TH	57R&57L	NEWV-05

## PT TECH

HPT014T-220SX-12VS-0		1	1ST	41R	PTTE-01
----------------------	--	---	-----	-----	---------

## RENAULT

BDSL-181		5	5TH		RENA-05
BDSL-2052R		5	5TH		RENA-05
BDSL-2142 OBSOLETE					
BDSL-2142R OBSOLETE					
BDSL-2152					N2
G405-0 (MACK)		5	5TH	37R	RENA-02
G405-1 (MACK)		5	5TH	37R	RENA-01
G406-0 (MACK)		6	5TH	37R	RENA-02

### Notes:

N3 – PTO Application Available From M-Power or Muncie Website.

N4 – Not Current Production Trans. – Contact Muncie for Application Info.



# 2018 TRANSMISSION INDEX

LET. CODE	MAKE MODEL	NO. FWD. SP'DS	DIRECT DRIVE IN.	TEETH IN PTO DRIVER	PTO APPL. NO
-----------	------------	----------------	------------------	---------------------	--------------

## RENAULT (Continued)

G406-1 (MACK T-1060B)					N2
T-105 (MACK)		5	5TH	37R	RENA-01
T-105A (MACK)		5	5TH	37R	RENA-02
T-1060A		5	5TH	37R	RENA-02

## STERLING BULLET

AS68RC		6	5TH	69R	AISN-02
--------	--	---	-----	-----	---------

## SPICER (SEE TREMEC)

## TOYOTA

M150 (TRANSFER CASE)		2	2ND		TOYO-01
M151 (TRANSFER CASE)		2	2ND		TOYO-01
M155 (TRANSFER CASE)		2	2ND		TOYO-01

## TREMEC

190F (TREMEC)		4	4TH	36R&36L	WARN-01
199A		4	4TH	36R	TREM-01
199F		4	4TH	36R	TREM-01
CL-559A		5	5TH	33R&19L	FULL-07
CL-559B		5	5TH	33R&19L	FULL-07
CL-559C		5	5TH	30R&19L	FULL-08
ES54-5A		5	5TH	33R&33L	SPCR-47
ES54-5B		5	5TH	32R&32L	SPCR-48
ES54-5C		5	5TH	33R&33L	SPCR-49
FS-5005A		5	5TH	33R&19L	FULL-07
FS-5005D		5	5TH	33R&19L	FULL-07
FSM-5305E		5	5TH	33R&33L	FULL-44
FSM-5305G		5	5TH	32R&32L	FULL-45
FSM-5305H		5	5TH	33R&33L	FULL-46
TR4040		5	4TH	32R	TREM-02
TR4050 (TDET-0880, -1361, -1664, -2196, -4812)		5	4TH	32R	TREM-02
TR7070		7	7TH	34R&34L	TREM-09
TR-S46-5A		5	5TH	32R&32L	TREM-03
TR-S56-5A		5	5TH	32R&32L	TREM-03
TR-S62-5A		5	5TH	41R&41L	TREM-04
TR-S62-5D		5	5TH	43R&43L	TREM-05
TR-S67-5A		5	5TH	41R&41L	TREM-04
TR-S67-5D		5	5TH	43R&43L	TREM-05
TR-S70-5A		5	5TH	40R&40L	TREM-06
TR-S70-5D		5	5TH	42R&42L	TREM-07
TR-S56-7B		7	7TH	34R&34L	TREM-08
TR-S066-7B		7	7TH	34R&34L	TREM-09
TR-T110-7B		7	7TH	56R&56L	TREM-10
TR-T110-7A		7	7TH	43R&43L	TREM-11
TR-T145-7A		7	7TH	43R&43L	TREM-11
TR-T86-10V		10	10TH	45R&45B	TREM-12
TR-T0115-10V		10	9TH	45R&45B	TREM-13
TR-T0145-10V		10	9TH	45R&45B	TREM-13
TR-T100-10D		10	10TH	45R&45B	TREM-14
TR-T145-10D		10	10TH	45R&45B	TREM-14
TR-S56-7B		7	7TH	34R&34L	TREM-08
TR-S066-7B		7	7TH	34R&34L	TREM-09
TR-T110-7B		7	7TH	56R&56L	TREM-10
TR-T110-7A		7	7TH	43R&43L	TREM-11
TR-T145-10D		10	10TH	45R&45B	TREM-14
TR-T0100-10S		10	9TH	45R&45B	TREM-15
TR-T0165-10S		10	9TH	45R&45B	TREM-15
TR-TDO165-18A		18	16TH	52R&52B	TREM-16
TR-TDO185-18A		18	16TH	52R&52B	TREM-16
TR-TDO205-18A		18	16TH	52R&52B	TREM-16

LET. CODE	MAKE MODEL	NO. FWD. SP'DS	DIRECT DRIVE IN.	TEETH IN PTO DRIVER	PTO APPL. NO
-----------	------------	----------------	------------------	---------------------	--------------

## TREMEC (FORMERLY SPICER)

The Bill of Material (B/M) numbers found on the TTC/Spicer I.D. can be used to differentiate between old and new transmissions. Typically only the new style transmissions are shown. Muncie does have PTOs for most of the old-style, out of production transmissions. Contact the Muncie Sales Department for assistance.

1007-2A (300959 & EARLIER)					N4
1007-2A (301117) (301206)	7	7TH	45R&45B	SPCR-01	N4
1007-2B (300960 & EARLIER)					N4
1007-2B (301118) (301207)	7	6TH	48R&48B	SPCR-38	
1007-3A (300965 & EARLIER)(1976 & BEFORE)	7	6TH	51R&51B		N3
1007-3A (301121) (301208)	7	5TH	54R&54B	SPCR-36	
1010-2A (300874 & EARLIER)					N4
1010-2A (301111)	10	10TH	49R&49B	SPCR-02	
1010-3A (300980 & EARLIER)					N4
1010-3A (301113)	10	9TH	54R&54B	SPCR-40	
1010-3B (300995 & EARLIER)					N4 1010-3B
(301115)	10	9TH	48R&48B	SPCR-03	
1010-4A (300964 & EARLIER)					N4
1010-4A (301112)	10	10TH	49R&49B	SPCR-02	
1010-5A (301069 & EARLIER)					N4
1010-5A (301114)	10	9TH	54R&54B	SPCR-40	
1020-2A (300875 & EARLIER)					N4
1020-2A (301123)	20	10TH	49R&49B	SPCR-02	
1020-3A (300894 & EARLIER)					N4
1020-3A (301125)	20	10TH	48R&48B	SPCR-03	
1020-4A (300982 & EARLIER)					N4
1020-4A (301124)	20	10TH	49R&49B	SPCR-02	
1020-5A (300983 & EARLIER)					N4
1020-5A (301126)	20	10TH	48R&48B	SPCR-03	
1052A (300883 & EARLIER)					N4
1052A (301091)	5	5TH	43R&43B	SPCR-33	
1054A (300963 & EARLIER)					N4
1054A (301092)	5	5TH	43R&43B	SPCR-33	
1062A (300835 & EARLIER)					N4
1062A (301101)	6	6TH	45R&45B	SPCR-01	
1062B (300836 & EARLIER)					N4
1062B (301103)	6	6TH	48R&48B	SPCR-04	
1062C (301132 & EARLIER)					N4
1062C (301133)	6	6TH	48R&48B	SPCR-38	
1062D (301148)	6	6TH	48R&48B	SPCR-04	
1064A (300961 & EARLIER)					N4
1064A (301102)	6	6TH	45R&45B	SPCR-01	
1064B (300962 & EARLIER)					N4
1064B (301104)	6	6TH	48R&48B	SPCR-04	
1064C (301135 & EARLIER)					N4
1064C (301136)	6	6TH	48R&48B	SPCR-38	
1064D (301149)	6	6TH	48R&48B	SPCR-04	
1107-2A (301201)	7	7TH	43R&43B	SPCR-34	
1207-2A (301195)	7	7TH	45R&45B	SPCR-01	
1207-2B (301196)	7	7TH	48R&48B	SPCR-38	
1207-2D (301240)	7	7TH	48R&48B	SPCR-38	
1207-3A (301199)	7	6TH	54R&54B	SPCR-36	
1211-3A	11	5TH	51R&51B		N3
1211-5A	11	5TH	51R&51B		N3
1214-2A (301128) (301210)	14	13TH	49R&49B	SPCR-42	
1214-3A (301072 & EARLIER)					N4
1214-3A (301130) (301212)	14	13TH	54R&54B	SPCR-05	

### Notes:

N2 – Not Current Production Transmission – No Muncie PTO.

N3 – PTO Application Available From M-Power or Muncie Website.

N4 – Not Current Production Trans. – Contact Muncie for Application Info.



# 2018 TRANSMISSION INDEX

LET. CODE	MAKE MODEL	NO. FWD. SP'DS	DIRECT DRIVE IN.	TEETH IN PTO DRIVER	PTO APPL. NO
-----------	------------	----------------	------------------	---------------------	--------------

## TREMEC (Continued)

1214-4A (301129) (301211)	14... 13TH	49R&49B	SPCR-42
1214-5A (301089 & EARLIER)			
N4			
1214-5A (301131) (301213)	14... 13TH	54R&54B	SPCR-05
1241C (300977, 301145, 301151)	4... 3RD	39R&39B	SPCR-16
1241CT	4... 3RD	39R&39B	SPCR-16
1241D (300978, 301146, 301152)	4... 3RD	39R&39B	SPCR-16
1241DT	4... 3RD	39R&39B	SPCR-16
1252A (300898 & EARLIER)			N4
1252A (301094)	5... 5TH	44R&44B	SPCR-06
1253A (300899 & EARLIER)			N4
1253A (301096)	5... 4TH	51R&51B	SPCR-07
1253B (300928 & EARLIER)			N4
1253B (301098)	5... 4TH	55R&55B	SPCR-08
1254A (300997 & EARLIER)			N4
1254A (301095)	5... 5TH	44R&44B	SPCR-06
1255A (301057 & EARLIER)			N4
1255A (301097)	5... 4TH	51R&51B	SPCR-07
1255B (301058 & EARLIER)			N4
1255B (301099)	5... 4TH	55R&55B	SPCR-08
1262A (1976 & BEFORE)	6... 6TH	51R&51B	N3
1262A (301105)	6... 6TH	45R&45B	SPCR-09
1263A (300834 & EARLIER)(1976 & BEFORE)			
	6... 5TH	51R&51B	N3
1263A (301107)	6... 5TH	54R&54B	SPCR-39
1263B (301076 & EARLIER)(1976 & BEFORE)			
	6... 5TH	51R&51B	N3
1263B (301109)	6... 5TH	54R&54B	SPCR-36
1264A	6... 6TH	51R&51B	N3
1264A (301106)	6... 6TH	45R&45B	SPCR-09
1265A	5... 4TH	51R&51B	N3
1265A (301108)	5... 4TH	54R&54B	SPCR-39
1272A (301139 & EARLIER)			N4
1272A (301140) (301215)	6... 6TH	48R&48B	SPCR-38
1272B (301158)	6... 6TH	48R&48B	SPCR-04
1274A (301134 & EARLIER)			N4
1274A (301141) (301216)	6... 6TH	48R&48B	SPCR-38
1274B (301159)	6... 6TH	48R&48B	SPCR-04
1310-2A (301292)	10... 10TH	51R&51B	SPCR-10
1310-4A (301317)	10... 10TH	51R&51B	SPCR-10
1352A (301235)	5... 5TH	43R&43B	SPCR-33
1362A (301169)	6... 6TH	45R&45B	SPCR-01
1362B (301171)	6... 6TH	48R&48B	SPCR-38
1362C (301178)	6... 6TH	48R&48B	SPCR-38
1362D (301180)	6... 6TH	48R&48B	SPCR-38
1364C (301179)	6... 6TH	48R&48B	SPCR-38
1372A (301271) (301398)	7... 7TH	43R&43B	SPCR-34
1372B (301325) (301405)	7... 7TH	56R&56B	SPCR-35
1374A (301272)	7... 7TH	43R&43B	SPCR-34
1410-2A (301288) (301161)	10... 10TH	49R&49B	SPCR-02
1410-3A (301163)	10... 10TH	54R&54B	SPCR-40
1410-3B (301165)	10... 9TH	48R&48B	SPCR-03
1412-3A (301227)	12... 11TH	54R&54B	SPCR-40
1414-2A (301242)	14... 13TH	49R&49B	SPCR-42
1414-3A (301243) (301290)	14... 13TH	54R&54B	SPCR-40
1420-3A (301232) (301239)	10... 9TH	54R&54B	SPCR-40
1420-3B (301332)	10... 9TH	54R&54B	SPCR-40
1452A (301183)	5... 5TH	44R&44B	SPCR-06
1453A (301185)	5... 4TH	51R&51B	SPCR-07
1453B (301187)	5... 4TH	55R&55B	SPCR-08
1462A (301173)	6... 6TH	45R&45B	SPCR-01
1463A (301175)	6... 5TH	54R&54B	SPCR-39
1463C (301357)	6... 5TH	54R&54B	SPCR-39

LET. CODE	MAKE MODEL	NO. FWD. SP'DS	DIRECT DRIVE IN.	TEETH IN PTO DRIVER	PTO APPL. NO
-----------	------------	----------------	------------------	---------------------	--------------

## TREMEC (Continued)

3152					N4
3152-A					N4
3152-B					N4
3152-C					N4
3152-D					N4
3152-E					N4
3153					N4
3153-A					N4
3153-B					N4
5652 (2, 6-BOLT OPENINGS)	5... 5TH	20R&24L	N3		
5652 (8-BOLT & 6-BOLT OPENING)	5... 5TH	41R&24L	N3		
5652A (2, 6-BOLT OPENINGS)	5... 5TH	20R&24L	N3		
5652A (8-BOLT & 6-BOLT OPENING)	5... 5TH	39R&24L	N3		
5652B (2, 6-BOLT OPENINGS)	5... 5TH	20R&24L	N3		
5652B (8-BOLT & 6-BOLT OPENING)	5... 5TH	41R&24L	N3		
5752 (2, 6-BOLT OPENINGS)	5... 5TH	20R&24L	N3		
5752 (8-BOLT & 6-BOLT OPENING)	5... 5TH	39R&24L	N3		
5752A (2, 6-BOLT OPENINGS)	5... 5TH	20R&24L	N3		
5752A (8-BOLT & 6-BOLT OPENING)	5... 5TH	39R&24L	N3		
5752B (2, 6-BOLT OPENINGS)	5... 5TH	20R&24L	N3		
5752C (2, 6-BOLT OPENINGS)	5... 5TH	20R&24L	N3		
5752C (8-BOLT & 6-BOLT OPENING)	5... 5TH	42R&24L	N3		
5753 (2, 6-BOLT OPENINGS)	5... 5TH	20R&24L	N3		
5753A	5... 5TH	48R&24L	N3		
5756 (2 6-BOLT OPENINGS)	5... 5TH	20R&24L	N3		
5756A (2 6-BOLT OPENINGS)	5... 5TH	20R&24L	N3		
5756B (2 6-BOLT OPENINGS)	5... 5TH	20R&24L	N3		
5756B (8-BOLT & 6-BOLT OPENING)	5... 5TH	43R&24L	N3		
5852	5... 5TH	20R&24L	N3		
5852A	5... 5TH	20R&24L	N3		
5852B	5... 5TH	20R&24L	N3		
6352 (300661)			N4		
6352-A			N4		
6354			N4		
6354-A			N4		
6452A	5... 5TH	22R&25L	N3		
6852	5... 5TH	21R&25L	N3		
6852D	5... 5TH	23R&25L	N3		
6852E	5... 5TH	23R&25L	N3		
6852G	5... 5TH	23R&25L	N3		
6852L	5... 5TH	23R&25L	N3		
6852Q	5... 5TH	23R&25L	N3		
6852R	5... 5TH	21R&25L	N3		
6853	5... 5TH	21R&25L	N3		
6853A	5... 5TH	21R&25L	N3		
6853B	5... 5TH	21R&25L	N3		
6853C	5... 4TH	23R&25L	N3		
6853G	5... 4TH	23R&25L	N3		
6853K	5... 4TH	23R&25L	N3		
6854	5... 5TH	21R&25L	N3		
6854G	5... 4TH	23R&25L	N3		
6855	5... 5TH	21R&25L	N3		
6855B	5... 5TH	21R&25L	N3		
6855C	5... 4TH	23R&25L	N3		
7041 (Auxiliary) (300528)	4... 4TH	31R	SPCR-46		
8012			N4		
8016			N4		
8041	4... 4TH	46R&46L	N3		
8041A	4... 4TH	46R&46L	N3		

### Notes:

N3 – PTO Application Available From M-Power or Muncie Website.

N4 – Not Current Production Trans. – Contact Muncie for Application Info.



# 2018 TRANSMISSION INDEX

LET. CODE	MAKE MODEL	NO. FWD. SP'DS	DIRECT DRIVE IN.	TEETH IN PTO DRIVER	PTO APPL. NO
-----------	------------	----------------	------------------	---------------------	--------------

## TREMEC (Continued)

8045		4	4TH	46R&46L	N3
8045A		4	4TH	46R&46L	N3
8051		5	4TH	46R&46L	N3
8051A		5	4TH	46R&46L	N3
8051B		5	4TH	46R&46L	N3
8051C		5	4TH	46R&46L	N3
8051D		5	4TH	46R&46L	N3
8052		5	5TH	46R&46L	N3
8052B		5	5TH	46R&46L	N3
8052D		5	5TH	46R&46L	N3
8054		5	5TH	46R&46L	N3
8054B		5	5TH	46R&46L	N3
8054D		5	5TH	46R&46L	N3
8055		5	4TH	46R&46L	N3
8055A		5	4TH	46R&46L	N3
8055B		5	4TH	46R&46L	N3
8055C		5	4TH	46R&46L	N3
8055D		5	4TH	46R&46L	N3
8081		8	4TH	46R&46L	N3
8085		8	4TH	46R&46L	N3
8516					N4
8542A		4	4TH	46R&46L	N3
8544A		4	4TH	46R&46L	N3
8552A		5	5TH	46R&46L	N3
8552B		5	5TH	46R&46L	N3
8553					N4
8553A		5	4TH	46R&46L	N3
8553B		5	4TH	46R&46L	N3
8554					N4
8554A		5	5TH	46R&46L	N3
8554B		5	5TH	46R&46L	N3
8555A		5	4TH	46R&46L	N3
8555B		5	4TH	46R&46L	N3
9072A (301321)		7	7TH	50R&50B	SPCR-31
AM01000-4C/4D (301474) (301475)		4	3RD	39R&39B	SPCR-16
AP01000-4C/4D (301476) (301477)		4	3RD	39R&39B	SPCR-16
AS100-10D (301612)		10	10TH	45R&45B	SPCR-51
AS125-10D (301613)		10	10TH	45R&45B	SPCR-51
AS125-9A		9	9TH	45R&45B	SPCR-30
AS135-10D (301614)		10	10TH	45R&45B	SPCR-51
AS135-9A		9	9TH	45R&45B	SPCR-30
AS140-9A		9	9TH	45R&45B	SPCR-30
AS145-10D (301615)		10	10TH	45R&45B	SPCR-51
AS56-7B		7	7TH	34R&34L	SPCR-56
ASO100-10S		10	9TH	45R&45B	SPCR-43
ASO10-VPD		10	9TH	45R&45B	SPCR-43
ASO125-10D		10	9TH	45R&45B	SPCR-52
ASO125-10S (301541)(301579)		10	9TH	45R&45B	SPCR-43
ASO125-9A		10	9TH	45R&45B	SPCR-52
ASO135-10D		10	9TH	45R&45B	SPCR-52
ASO135-9A		10	9TH	45R&45B	SPCR-52
ASO140-10S (301542)(301580)		10	9TH	45R&45B	SPCR-43
ASO140-9A		9	8TH	45R&45B	SPCR-37
ASO145-9A		9	8TH	45R&45B	SPCR-37
ASO150-10S (301526) (301578)		10	9TH	45R&45B	SPCR-43
ASO150-9A		9	8TH	45R&45B	SPCR-37
ASO165-10S (301543) (301581)		10	9TH	45R&45B	SPCR-43
ASO56-7A (301452) (301636)		7	6TH	34R&34L	SPCR-29
ASO56-7B		7	6TH	34R&34L	SPCR-29
ASO66-7A (301452) (301636)		7	6TH	34R&34L	SPCR-29
ASO66-7B		7	6TH	34R&34L	SPCR-29
ATO1000-4C/4D		4	3RD	39R&39B	SPCR-16
ATO1750-4C/4D		4	3RD	39R&39B	SPCR-16

LET. CODE	MAKE MODEL	NO. FWD. SP'DS	DIRECT DRIVE IN.	TEETH IN PTO DRIVER	PTO APPL. NO
-----------	------------	----------------	------------------	---------------------	--------------

## TREMEC (Continued)

CM-4054A (301329) (301420)		5	5TH	40R&40L	SPCR-17
CM-4054D (301343) (301421)		5	5TH	42R&42L	SPCR-18
CM-4954A (301386)		5	5TH	32R&32L	SPCR-19
CM-4954D (301387)		5	5TH	34R&34L	SPCR-20
CM-5052A (301068) (301472)		5	5TH	41R&41L	SPCR-22
CM-5052B (301248) (301079)		5	5TH	39R&39L	SPCR-11
CM-5052C (301249) (301080)		5	5TH	41R&41L	SPCR-22
CM-5052D (301250) (301230)		5	5TH	43R&43L	SPCR-23
CM50-HD		5	5TH	43R&43L	SPCR-24
CM-5252A (301251) (301081)		5	5TH	43R&43L	SPCR-24
CM-5510 (301315) (301371)		5	5TH	41R&41L	SPCR-22
CM-5552A (301309) (301366)		5	5TH	41R&41L	SPCR-22
CM-5552B (301310) (301367)		5	5TH	39R&39L	SPCR-11
CM-5552C (301311) (301368)		5	5TH	41R&41L	SPCR-22
CM-5552D (301312) (301369)		5	5TH	43R&43L	SPCR-23
CM-5852A (301313) (301370)		5	5TH	43R&43L	SPCR-24
CM-5952A (301360)		5	5TH	41R&41L	SPCR-22
CM-5952B (301361)		5	5TH	39R&39L	SPCR-11
CM-5952C (301362)		5	5TH	41R&41L	SPCR-22
CM-5952D (301363)		5	5TH	43R&43L	SPCR-23
CM-5952E (301364)		5	5TH	43R&43L	SPCR-24
CM-6052A (301253) (301075) (301413)		5	5TH	40R&40L	SPCR-25
CM-6052B (301254) (301082) (301414)		5	5TH	38R&38L	SPCR-26
CM-6052C (301255) (301083) (301415)		5	5TH	42R&42L	SPCR-28
CM-6052D (301256) (301416)		5	5TH	42R&42L	SPCR-27
CM-6252A (301257) (301084)		5	5TH	39R&39L	SPCR-12
CM-6252B (301258) (301085) (301417)		5	5TH	35R&35L	SPCR-13
CM-6253A (301259) (301086)		5	4TH	44R&44L	SPCR-14
CM-6253B (301260) (301087) (301418)		5	4TH	46R&46L	SPCR-15
CV67F		5	5TH	42R&42L	SPCR-27
ES42-5A (301438)		5	5TH	40R&40L	SPCR-17
ES42-5D (301439)		5	5TH	42R&42L	SPCR-18
ES43-5A (301510) (301633)		5	5TH	32R&32L	SPCR-19
ES43-5D (301511) (301634)		5	5TH	34R&34L	SPCR-20
ES46-5A		5	5TH	32R&32L	SPCR-55
ES46-5D		5	5TH	34R&34L	SPCR-58
ES52-5A (301455)		5	5TH	32R&32L	SPCR-19
ES52-5D (301456)		5	5TH	34R&34L	SPCR-20
ES52-7A (301451) (301635)		7	7TH	34R&34L	SPCR-21
ES52-7B (301642) (301637)		7	7TH	34R&34L	SPCR-21
ES53-5A (301508) (301631)		5	5TH	32R&32L	SPCR-19
ES53-5D (301509) (301632)		5	5TH	34R&34L	SPCR-20
ES54-5A		5	5TH	33R&33L	SPCR-47
ES54-5B		5	5TH	32R&32L	SPCR-48
ES54-5C		5	5TH	33R&33L	SPCR-49
ES55-5D		5	5TH	43R&43L	SPCR-23
ES56-5A		5	5TH	32R&32L	SPCR-55
ES56-5D		5	5TH	34R&34L	SPCR-58
ES56-7B (301739)		7	7TH	34R&34L	SPCR-56
ES60-5A (301460)		5	5TH	41R&41L	SPCR-22
ES60-5C (301461)		5	5TH	41R&41L	SPCR-22
ES60-5D (301462)		5	5TH	43R&43L	SPCR-23
ES60-5E (301463)		5	5TH	43R&43L	SPCR-24
ES60-5F (301482)		5	5TH	41R&41L	SPCR-22
ES62-5A (301528)		5	5TH	41R&41L	SPCR-22
ES62-5D (301530)		5	5TH	43R&43L	SPCR-23
ES65-5A (301466)		5	5TH	40R&40L	SPCR-25
ES65-5B (301467)		5	5TH	38R&38L	SPCR-26
ES65-5D (301469)		5	5TH	42R&42L	SPCR-27

### Notes:

N3 – PTO Application Available From M-Power or Muncie Website.

N4 – Not Current Production Trans. – Contact Muncie for Application Info.



# 2018 TRANSMISSION INDEX

LET. CODE	MAKE MODEL	NO. FWD. SP'DS	DIRECT DRIVE IN.	TEETH IN PTO DRIVER	PTO APPL. NO
-----------	------------	----------------	------------------	---------------------	--------------

## TREMEC (Continued)

ES65-5E (301468)	5	5TH	42R&42L	SPCR-28
ES67-5A (301532)	5	5TH	41R&41L	SPCR-22
ES67-5D (301534)	5	5TH	43R&43L	SPCR-23
ES68-5D	5	5TH	43R&43L	SPCR-23
ES70-5A (301536)	5	5TH	40R&40L	SPCR-25
ES70-5D (301539)	5	5TH	42R&42L	SPCR-27
ES72-5A	5	5TH	40R&40L	SPCR-25
ES72-5B (301637)	5	4TH	46R&46L	SPCR-15
ES72-5C	5	5TH	42R&42L	SPCR-27
ES72-5D	5	5TH	42R&42L	SPCR-27
ESO65-7A (301452) (301636)	7	6TH	34R&34L	SPCR-29
ESO66-7B (301643) (301638)(301742)	7	6TH	34R&34L	SPCR-29
ESO67-7B	7	6TH	34R&34L	SPCR-57
ESO77-7B	7	6TH	34R&34L	SPCR-57
LAS100-10D (301616)	10	10TH	45R&45B	SPCR-51
LAS115-9A (301590)	9	9TH	45R&45B	SPCR-30
LAS125-10D (301617)	10	10TH	45R&45B	SPCR-51
LAS125-9A (301591)	9	9TH	45R&45B	SPCR-30
LAS135-10D (301618)	10	10TH	45R&45B	SPCR-51
LAS135-9A (301592)	9	9TH	45R&45B	SPCR-30
LAS140-9A	9	9TH	45R&45B	SPCR-30
LAS145-10D (301619)	10	10TH	45R&45B	SPCR-51
LAS145-9A (301593)	9	9TH	45R&45B	SPCR-30
LASO10-VPD	10	9TH	45R&45B	SPCR-43
LASO115-9A (301594)	9	8TH	45R&45B	SPCR-37
LASO125-10S (301620)	10	9TH	45R&45B	SPCR-43
LASO125-9A (301595)	9	8TH	45R&45B	SPCR-37
LASO135-9A (301597)	9	8TH	45R&45B	SPCR-37
LASO140-10S (301621)	10	9TH	45R&45B	SPCR-43
LASO140-9A	9	8TH	45R&45B	SPCR-37
LASO145-9A (301596)	9	8TH	45R&45B	SPCR-37
LASO150-10S (301622)	10	9TH	45R&45B	SPCR-43
LASO150-9A	9	8TH	45R&45B	SPCR-37
LLAS100-10D	10	10TH	45R&45B	SPCR-51
LLAS125-10D	10	10TH	45R&45B	SPCR-51
LLAS135-10D	10	10TH	45R&45B	SPCR-51
LLAS145-10D	10	10TH	45R&45B	SPCR-51
LLASO125-10S	10	9TH	45R&45B	SPCR-32
LLASO140-10S	10	9TH	45R&45B	SPCR-32
LLASO150-10S	10	9TH	45R&45B	SPCR-32
LLPS100-10D	10	10TH	45R&45B	SPCR-51
LLPS125-10D	10	10TH	45R&45B	SPCR-51
LLPS135-10D	10	10TH	45R&45B	SPCR-51
LLPS145-10D (301703)	10	10TH	45R&45B	SPCR-51
LLPSO100-10S	10	9TH	45R&45B	SPCR-32
LLPSO125-10S	10	9TH	45R&45B	SPCR-32
LLPSO140-10S (301705)	10	9TH	45R&45B	SPCR-32
LLPSO150-10S	10	9TH	45R&45B	SPCR-32
LLPSO165-10S	10	9TH	45R&45B	SPCR-32
LPS100-10D (301608)	10	10TH	45R&45B	SPCR-51
LPS125-10D (301609)	10	10TH	45R&45B	SPCR-51
LPS125-9A (301547) (301567)	9	9TH	45R&45B	SPCR-30
LPS135-10D (301610)	10	10TH	45R&45B	SPCR-51
LPS140-9A (301549) (301569)	9	9TH	45R&45B	SPCR-30
LPS145-10D (301611)	10	10TH	45R&45B	SPCR-51
LPS9-VPD (301549)	9	9TH	45R&45B	SPCR-30
LPSO100-10S	10	9TH	45R&45B	SPCR-32
LPSO10-VPD	10	9TH	45R&45B	SPCR-32
LPSO125-10S (301544) (301572)	10	9TH	45R&45B	SPCR-32
LPSO125-9A (301548) (301568)	9	8TH	45R&45B	SPCR-37
LPSO140-10S (301545) (301573)	10	9TH	45R&45B	SPCR-32
LPSO140-9A (301550) (301570)	9	8TH	45R&45B	SPCR-37
LPSO150-10S (301546) (301574)	10	9TH	45R&45B	SPCR-32

LET. CODE	MAKE MODEL	NO. FWD. SP'DS	DIRECT DRIVE IN.	TEETH IN PTO DRIVER	PTO APPL. NO
-----------	------------	----------------	------------------	---------------------	--------------

## TREMEC (Continued)

LPSO150-9A (301551) (301571)	9	8TH	45R&45B	SPCR-37
LPSO165-10S	10	9TH	45R&45B	SPCR-32
PSO9-VPD (301551)(301571)	9	8TH	45R&45B	SPCR-37
P1241C (301053) (301395)	4	3RD	39R&39B	SPCR-16
P1241D (301054) (301396)	4	3RD	39R&39B	SPCR-16
PS100-10D (301604)	10	10TH	45R&45B	SPCR-51
PS105-7LL (301464)	5	5TH	43R&43B	SPCR-33
PS110-7A (301519)	7	7TH	43R&43B	SPCR-34
PS110-7B (301518)	7	7TH	56R&56B	SPCR-35
PS125-10D (301605)	10	10TH	45R&45B	SPCR-51
PS125-7LL (301464)	7	7TH	56R&56B	SPCR-35
PS125-9A (301431)(301554)	9	9TH	45R&45B	SPCR-30
PS130-10A (301485)	10	10TH	51R&51B	SPCR-10
PS130-12A (301484)	12	12TH	51R&51B	SPCR-10
PS130-5A (301470)	5	5TH	43R&43B	SPCR-33
PS130-6B (301471)	6	6TH	48R&48B	SPCR-38
PS130-6L (301465)	6	6TH	43R&43B	SPCR-33
PS135-10D (301606)	10	10TH	45R&45B	SPCR-51
PS140-7A (301444)	7	7TH	43R&43B	SPCR-34
PS140-9A (301495) (301555)	9	9TH	45R&45B	SPCR-30
PS145-10D (301607)	10	10TH	45R&45B	SPCR-51
PS145-7A (301520)	7	7TH	43R&43B	SPCR-34
PS85-10LL	10	10TH	51R&51B	SPCR-10
PS85-14-4L (301525)	10	10TH	51R&51B	SPCR-10
PS86-10V (301587)	10	10TH	45R&45B	SPCR-44
PS95-9A (301500) (301553)	9	9TH	45R&45B	SPCR-30
PS97-7A (301446)	7	7TH	50R&50B	SPCR-31
PS9-VPD	9	9TH	45R&45B	SPCR-30
PSO0165-18A	18	16TH	52R&52L	SPCR-59
PSO0185-18A	18	16TH	52R&52L	SPCR-59
PSO0205-18A	18	16TH	52R&52L	SPCR-59
PSO100-10S (301505) (301560)	10	9TH	45R&45B	SPCR-32
PSO10-VPD	10	9TH	45R&45B	SPCR-32
PSO115-10V (301588)	10	9TH	45R&45B	SPCR-45
PSO120-8LL(301644)	8	6TH	54R&54B	SPCR-36
PSO125-10D	10	9TH	45R&45B	SPCR-52
PSO125-10S (301504)(301561)	10	9TH	45R&45B	SPCR-32
PSO125-10V (301589)	10	9TH	45R&45B	SPCR-45
PSO125-9A (301499)(301556)	9	8TH	45R&45B	SPCR-37
PSO135-10D	10	9TH	45R&45B	SPCR-52
PSO140-10S (301506)(301562)	10	9TH	45R&45B	SPCR-32
PSO140-12B (301473)	12	11TH	54R&54B	SPCR-40
PSO140-14A (301483)	14	13TH	54R&54B	SPCR-40
PSO140-6A (301472)	6	5TH	54R&54B	SPCR-39
PSO140-6C (301486)	6	5TH	54R&54B	SPCR-39
PSO140-9A (301432)(301557)	9	8TH	45R&45B	SPCR-37
PSO145-10D	10	9TH	45R&45B	SPCR-52
PSO145-10V (301582)	10	9TH	45R&45B	SPCR-45
PSO150-10S (301503)(301563)	10	9TH	45R&45B	SPCR-32
PSO150-16A (301641)	16	15TH	54R&54B	SPCR-39
PSO150-16B (301647)	16	15TH	56R&56B	SPCR-41
PSO150-9A (301496)(301558)	9	8TH	45R&45B	SPCR-37
PSO150-9S (301521)	9	8TH	45R&45B	SPCR-32
PSO155-10D	10	9TH	45R&45B	SPCR-52
PSO160-10S (301517)	10	9TH	45R&45B	SPCR-32
PSO165-10D	10	9TH	45R&45B	SPCR-52
PSO165-10S (301523)(301564)	10	9TH	45R&45B	SPCR-32
PSO165-16B (301583)	16	15TH	56R&56B	SPCR-41
PSO165-18A (301666)	18	17TH	57R&57B	SPCR-50
PSO165-18B	18	17TH	57R&57B	SPCR-50
PSO175-16B (301584)	16	15TH	56R&56B	SPCR-41
PSO175-16M (301645)	16	15TH	56R&56B	SPCR-41
PSO175-16SM (301864)	16	15TH	84R&84B	SPCR-53





# 2018 TRANSMISSION INDEX

LET. CODE	MAKE MODEL	NO. FWD. SP'DS	DIRECT DRIVE IN.	TEETH IN PTO DRIVER	PTO APPL. NO
-----------	------------	----------------	------------------	---------------------	--------------

## TREMEC (Continued)

PSO175-18A (301585)	18... 17TH	57R&57B	SPCR-50
PSO175-18B	18... 17TH	57R&57B	SPCR-50
PSO175-18M (301849)	18... 17TH	57R&57B	SPCR-50
PSO175-18SM	18... 17TH	76R&76B	SPCR-54
PSO85-10LL	12... 11TH	54R&54B	SPCR-40
PSO85-14-4L	12... 11TH	54R&54B	SPCR-40
PSO9-VPD	9... 8TH	45R&45B	SPCR-37
R8516			N4
RP8516			N4
T-9505-2A (301408)	5... 5TH	43R&43B	SPCR-33
T-9505-2B (301425)	5... 5TH	43R&43B	SPCR-33
TR7070	7... 6TH	34R&34L	SPCR-29
TSP120-12A	12... 12TH	51R&51B	N3
TSP145-16B	16... 16TH	54R&54B	N3
TSP0140-12C	12... 11TH	49R&49B	N3
TSP0145-14A	14... 13TH	56R&56B	N3
TSP0145-16B	16... 15TH	56R&56B	SPCR-41
TSP0150-12A	12... 11TH	49R&49B	N3
TSP0155-14HP	14... 13TH	56R&56L	N3
TSP0155-16 H.P.	16... 15TH	56R&56B	SPCR-41
TSP0155-16A	16... 15TH	54R&54B	SPCR-39
TSP0155-16B	16... 15TH	56R&56B	SPCR-41
TSP0165-16 H.P.	16... 15TH	56R&56B	SPCR-41
TSP0165-18 H.P.	18... 17TH	57R&57B	N3
TSP0165-18A	18... 17TH	57R&57B	N3
TSP0175-16 MEGA	16... 15TH	56R&56B	SPCR-41
TSP0175-18 MEGA	18... 17TH		N2
TSP0180-16SM (301853)	16... 15TH	84R&84B	SPCR-53
TSP0180-18SM (301855)	18... 17TH	76R&76B	SPCR-54

## UD TRUCK

450-43L	4... 3RD	58L	AISS-01
MES-50A	5... 5TH	34L	NISS-04
MES-50B	5... 5TH	33L	NISS-05
MES-50C	5... 5TH	32L	NISS-06
MHS-50U	5... 5TH	23L	NISS-02
MHS-60A	6... 6TH	23L	NISS-02
MHS-61A	6... 6TH	23L	NISS-02
MHS-62A, MHS-63A	6... 6TH	23L	NISS-02
MLS-61A	6... 6TH	25L	NISS-03
MLS-61B	6... 6TH	25L	NISS-03
MLS-62B	6... 6TH	25L	NISS-03
MLS-63B	6... 6TH	25L	NISS-03
MPS-60B	6... 6TH		NISS-08
MPS-62T	6... 6TH	42L	NISS-07
MPS-63B	6... 6TH		NISS-09
RGE-40A AUTOMATIC	4... 3RD	63L	JATC-01
TMH-263	5... 5TH	23L	NISS-01
TMH-704	5... 5TH	23L	NISS-02
TMH-762	6... 6TH	23L	NISS-02

LET. CODE	MAKE MODEL	NO. FWD. SP'DS	DIRECT DRIVE IN.	TEETH IN PTO DRIVER	PTO APPL. NO
-----------	------------	----------------	------------------	---------------------	--------------

## VOLVO

AT2512C, VT2512C	12... 12TH				VOLV-04
AT2812C, VT2812C	12... 12TH				VOLV-04
ATO2512C, VTO2512C	12... 11TH				VOLV-05
ATO3112C, VTO3112C	12... 11TH				VOLV-05
R1700	9... 8TH				VOLV-01
R52	8... 8TH				VOLV-02
SR1700	14... 12TH				VOLV-01
VT1309	9... 8TH				VOLV-01
VT1414	14... 14TH				VOLV-01
VT2214B	14... 14TH				VOLV-03
VT809	9... 8TH				VOLV-01
AT2612D	12... 12th				VOLV-04
ATO2612C, ATO2612, ATO3112D	12... 11th				VOLV-05

## WARNER

1356 TRANSFER CASE	2... 2ND	57R	WARN-05
1370 TRANSFER CASE	2... 2ND	57R	WARN-05
4401 TRANSFER CASE	2... 2ND	57R	WARN-05
4407 TRANSFER CASE (PTO OBSOLETE)	2... 2ND	57R	WARN-06
4470 TRANSFER CASE	2... 2ND	57R	WARN-05
T-18	4... 4TH	36R&36L	WARN-01
T-18A	4... 4TH	32R&32L	WARN-02
T-18B	4... 4TH	32R&32L	WARN-03
T-18C	4... 4TH	32R&32L	WARN-02
T-19	4... 4TH	36R&36L	WARN-01
T-19A	4... 4TH	32R&32L	WARN-03
T-19A (4.02 LOW GEAR)	4... 4TH	32R&32L	WARN-04
T-19C	4... 4TH	32R&32L	WARN-04
T-19D	4... 4TH	32R&32L	WARN-02
T-98-1R	4... 4TH	36R&36L	WARN-01
T-98-1V	4... 4TH	36R&36L	WARN-01
T-98A	4... 4TH	36R&36L	WARN-01

## ZED F

6S-380	6... 5TH		ZEDF-09
6S-650 (5.79-0.72 RATIO)(1999-2007 FORD) ...	6... 5TH	39L	ZEDF-04
6S-650 (5.79-0.72 RATIO)(2001-2006 GMC 3600 CHEV-3)	6... 5TH	39R&39L	ZEDF-04
6S-750 (2008 & later Ford)	6... 6TH		ZEDF-08
6S-850 (Hyundai/Bering)	6... 6TH		ZEDF-05
9S-75 (13.16 1ST)	9... 9TH		ZEDF-07
S5-35	5... 5TH		ZEDF-06
S5-42 (4.14-0.77 RATIO)	5... 4TH	41R&41L	ZEDF-01
S5-42 (5.72-0.76 RATIO)	5... 4TH	45R&45L	ZEDF-02
S5-47 (5.08-0.77 RATIO)	5... 4TH	43R&43L	ZEDF-03
S5-47 (5.72-0.76 RATIO)	5... 4TH	45R&45L	ZEDF-02

### Notes:

N2 – Not Current Production Transmission – No Muncie PTO.

N3 – PTO Application Available From M-Power or Muncie Website.

N4 – Not Current Production Trans. – Contact Muncie for Application Info.



# 2018 TRANSMISSION INDEX

LET. CODE	MAKE MODEL	NO. FWD. SP'DS	DIRECT DRIVE IN.	TEETH IN PTO DRIVER	PTO APPL. NO
-----------	------------	----------------	------------------	---------------------	--------------

## ZF (ZF/MERITOR)

### MERITOR MODEL NUMBERS:

Models: Ex.: MO-16F10C-E18 or MO-16F10C-M18 are the same PTO application.  
 Suffix: A=Automated, E=ESS ZF MERITOR TCU, D=ESS-DDC ECU, S=Shift-by-Wire, M=Manual

### FORMER ROCKWELL MODEL NUMBERS:

Models: Ex.: RMX13-145A or RSX13-145A (Transmission Model NO. beginning "RS" or "RSX" are the same applications as the standard "RM" and "RMX" models.) RMO and RMX designate overdrive and are the same PTO application.

M-11F10A-E11 (S11)	10... 10TH	45R&45	MERT-01
M-11F9A-E11 (S11)	9... 9TH	45R&45	MERT-01
M-11G10A-M11 (D11) (E11) (S11)	10... 10TH	45R&45B	MERT-01
M-11G9A-M11 (D11) (E11) (S11)	9... 9TH	45R&45B	MERT-01
M-12F10A-E12 (S12)	10... 10TH	45R&45	MERT-01
M-12F9A-E12 (S12)	9... 9TH	45R&45	MERT-01
M-12G10A-D12 (E12)	10... 10TH	45R&45	MERT-01
M-12G10A-M12 (D12) (E12) (S12)	10... 10TH	45R&45B	MERT-01
M-12G9A-M12 (D12) (E12) (S12)	9... 9TH	45R&45B	MERT-01
M-13F10A-E13 (S13)	10... 10TH	45R&45	MERT-01
M-13F9A-E13 (S13)	9... 9TH	45R&45	MERT-01
M-13G10A-M13 (D13) (E13) (S13)	10... 10TH	45R&45B	MERT-01
M-13G9A-M13 (D13) (E13) (S13)	9... 9TH	45R&45B	MERT-01
M-13Z12A-A13 (Direct Drive)	12... 12th		MERT-05
(FREEDOMLINE)			
M-14F10A-E14 (S14)	10... 10TH	45R&45	MERT-01
M-14F10A-M16	10... 10TH	45R&45B	MERT-01
M-14F10A-S15	10... 10TH	45R&45	MERT-01
M-14F9A-E14 (S14)	9... 9TH	45R&45	MERT-01
M-14G10A-M14 (D14) (E14) (S14)	10... 10TH	45R&45B	MERT-01
M-14G10A-M16 (D16) (E16) (S16)	10... 10TH	45R&45B	MERT-01
M-14G9A-M14 (D14) (E14) (S14)	9... 9TH	45R&45B	MERT-01
M-14Z12A-A14 (Direct Drive)	12... 12th		MERT-05
(FREEDOMLINE)			
M-15F10A-E15 (S15)	10... 10TH	45R&45	MERT-01
M-15G10A-M15 (D15) (E15) (S15)	10... 10TH	45R&45B	MERT-01
M-15G9A-M15 (D15) (E15) (S15)	9... 9TH	45R&45B	MERT-01
MO-11F10A-S11	10... 10TH	45R&45	MERT-02
MO-11F10C-E11 (S11)	10... 10TH	45R&45	MERT-04
MO-11F9B-E11 (S11)	9... 9TH	45R&45	MERT-03
MO-11G10A-M11 (D11) (E11) (S11)	10... 9TH	45R&45B	MERT-02
MO-11G10C-M11 (D11) (E11) (S11)	10... 9TH	45R&45B	MERT-04
MO-11G9B-M11 (D11) (E11) (S11)	9... 8TH	45R&45B	MERT-03
MO-11G9R-M11	9... 8TH	45R&45B	MERT-02
MO-12F10A-E12 (S12)	10... 9TH	45R&45	MERT-02
MO-12F10C-E12 (S12)	10... 9TH	45R&45	MERT-04
MO-12F9A-E12 (S12)	9... 8TH	45R&45	MERT-02
MO-12F9B-E12 (S12)	9... 8TH	45R&45	MERT-03
MO-12G10A-M12 (D12) (E12) (S12)	10... 9TH	45R&45B	MERT-02
MO-12G10C-M12 (D12) (E12) (S12)	10... 9TH	45R&45B	MERT-04
MO-12G9A-M12 (D12) (E12) (S12)	9... 8TH	45R&45B	MERT-02
MO-12G9B-M12 (D12) (E12) (S12)	9... 8TH	45R&45B	MERT-03
MO-12G9R-M12	9... 8TH	45R&45B	MERT-02
MO-13F10A-E13 (S13)	10... 9TH	45R&45	MERT-02
MO-13F10C-E13 (S13)	10... 9TH	45R&45	MERT-04
MO-13F9A-E13 (S13)	9... 8TH	45R&45	MERT-02
MO-13F9B-E13 (S13)	9... 8TH	45R&45	MERT-03
MO-13G10A-M13 (D13) (E13) (S13)	10... 9TH	45R&45B	MERT-02
MO-13G10C-M13 (D13) (E13) (S13)	10... 9TH	45R&45B	MERT-04
MO-13G9A-M13 (D13) (E13) (S13)	9... 8TH	45R&45B	MERT-02
MO-13G9B-M13 (D13) (E13) (S13)	9... 8TH	45R&45B	MERT-03
MO-13G9R-M13	9... 8TH	45R&45B	MERT-02
MO-13Z12A-A13	12... 11TH		MERT-05
(FREEDOMLINE)			

LET. CODE	MAKE MODEL	NO. FWD. SP'DS	DIRECT DRIVE IN.	TEETH IN PTO DRIVER	PTO APPL. NO
-----------	------------	----------------	------------------	---------------------	--------------

## ZF (ZF/MERITOR) (Continued)

MO-13Z16A-A13	16... 15TH				MERT-06
(FREEDOMLINE)					
MO-14F10A-E14 (S14)	10... 9TH	45R&45	MERT-02		
MO-14F10A-M16	10... 9TH	45R&45B	MERT-02		
MO-14F10C-E14 (S14)	10... 9TH	45R&45	MERT-04		
MO-14F10C-M16	10... 9TH	45R&45B	MERT-04		
MO-14F9A-E14 (S14)	9... 8TH	45R&45	MERT-02		
MO-14F9B-E14 (S14)	9... 8TH	45R&45	MERT-03		
MO-14G10A-M14 (D14) (E14) (S14)	10... 9TH	45R&45B	MERT-02		
MO-14G10A-M16 (D16) (E16) (S16)	10... 9TH	45R&45B	MERT-02		
MO-14G10C-M14 (D14) (E14) (S14)	10... 9TH	45R&45B	MERT-04		
MO-14G10C-M16 (D16) (E16) (S16)	10... 9TH	45R&45B	MERT-04		
MO-14G9A-M14 (D14) (E14) (S14)	9... 8TH	45R&45B	MERT-02		
MO-14G9B-M14 (D14) (E14) (S14)	9... 8TH	45R&45B	MERT-03		
MO-14G9R-M14	9... 8TH	45R&45B	MERT-02		
MO-14Z12A-A14	12... 11TH		MERT-05		
(FREEDOMLINE)					
MO-14Z16A-A14	16... 15TH		MERT-06		
(FREEDOMLINE)					
MO-15F10A-E15 (S15)	10... 9TH	45R&45	MERT-02		
MO-15F10C-E15 (S15)	10... 9TH	45R&45	MERT-04		
MO-15F9B-E15 (S15)	9... 8TH	45R&45	MERT-03		
MO-15G10A-M15 (D15) (E15) (S15)	10... 9TH	45R&45B	MERT-02		
MO-15G10C-M15 (D15) (E15) (S15)	10... 9TH	45R&45B	MERT-04		
MO-15G9B-M15 (D15) (E15) (S15)	9... 8TH	45R&45B	MERT-03		
MO-15Z12A-A15	12... 11TH		MERT-05		
(FREEDOMLINE)					
MO-15Z16A-A15	16... 15TH		MERT-06		
(FREEDOMLINE)					
MO-16F10A-E16 (S16)	10... 9TH	45R&45	MERT-02		
MO-16F10C-M18 (D18) (E18) (S18)	10... 9TH	45R&45B	MERT-04		
MO-16G10A-M16 (D16) (E16) (S16)	10... 9TH	45R&45B	MERT-02		
MO-16G10C-M16 (D16) (E16) (S16)	10... 9TH	45R&45B	MERT-04		
MO-16G10C-M18 (D18) (E18) (S18)	10... 9TH	45R&45B	MERT-04		
MO-16Z12A-A16	12... 11TH		MERT-05		
(FREEDOMLINE)					
MO-16Z16A-A16	16... 15TH		MERT-06		
(FREEDOMLINE)					
MO-17G10C-M17 (D17) (E17) (S17)	10... 9TH	45R&45B	MERT-04		
MO-17G10C-M19 (D19) (E19) (S19)	10... 9TH	45R&45B	MERT-04		
MO-18G10C-M18 (D18) (E18) (S18)	10... 9TH	45R&45B	MERT-04		
MO-18G10C-M20 (D20) (E20) (S20)	10... 9TH	45R&45B	MERT-04		
RD10-145A	10... 10TH	45R&45B	MERT-01		
RE10-115A	10... 10TH	45R&45	MERT-01		
RE10-125A	10... 10TH	45R&45	MERT-01		
RE10-135A	10... 10TH	45R&45	MERT-01		
RE10-145A	10... 10TH	45R&45	MERT-01		
RE10-155A	10... 10TH	45R&45	MERT-01		
RE9-115A	9... 9TH	45R&45	MERT-01		
RE9-125A	9... 9TH	45R&45	MERT-01		
RE9-135A	9... 9TH	45R&45	MERT-01		
RE9-145A	9... 9TH	45R&45	MERT-01		
RE9-155A	9... 9TH	45R&45	MERT-01		
RE09-115B	9... 8TH	45R&45	MERT-03		
RE09-125A	9... 8TH	45R&45	MERT-02		
RE09-125B	9... 8TH	45R&45	MERT-03		
RE09-135A	9... 8TH	45R&45	MERT-02		
RE09-135B	9... 8TH	45R&45	MERT-03		
RE09-145A	9... 8TH	45R&45	MERT-02		
RE09-145B	9... 8TH	45R&45	MERT-03		
RE09-155B	9... 8TH	45R&45	MERT-03		
REX10-115A	10... 9TH	45R&45	MERT-02		
REX10-115C	10... 9TH	45R&45	MERT-04		
REX10-125A	10... 9TH	45R&45	MERT-02		



# 2018 TRANSMISSION INDEX

LET. CODE	MAKE MODEL	NO. FWD. SP'DS	DIRECT DRIVE IN.	TEETH IN PTO DRIVER	PTO APPL. NO
-----------	------------	----------------	------------------	---------------------	--------------

## ZF (ZF/MERITOR) (Continued)

REX10-125C	10	9TH	45R&45	MERT-04
REX10-135A	10	9TH	45R&45	MERT-02
REX10-135C	10	9TH	45R&45	MERT-04
REX10-145A	10	9TH	45R&45	MERT-02
REX10-145C	10	9TH	45R&45	MERT-04
REX10-155A	10	9TH	45R&45	MERT-02
REX10-155C	10	9TH	45R&45	MERT-04
REX10-165A	10	9TH	45R&45	MERT-02
REX10-165C	10	9TH	45R&45	MERT-04
REX9-115B	9	8TH	45R&45	MERT-03
REX9-115R	9	8TH	45R&45	MERT-03
REX9-125A	9	8TH	45R&45	MERT-02
REX9-125B	9	8TH	45R&45	MERT-03
REX9-125R	9	8TH	45R&45	MERT-03
REX9-135A	9	8TH	45R&45	MERT-02
REX9-135B	9	8TH	45R&45	MERT-03
REX9-135R	9	8TH	45R&45	MERT-03
REX9-145A	9	8TH	45R&45	MERT-02
REX9-145B	9	8TH	45R&45	MERT-03
REX9-145R	9	8TH	45R&45	MERT-03
REX9-155B	9	8TH	45R&45	MERT-03
RM10-115A	10	10TH	45R&45B	MERT-01
RM10-125A	10	10TH	45R&45B	MERT-01
RM10-135A	10	10TH	45R&45B	MERT-01
RM10-145A	10	10TH	45R&45B	MERT-01
RM10-145AT	10	10TH	45R&45B	MERT-01
RM10-155A	10	10TH	45R&45B	MERT-01
RM9-115A	9	9TH	45R&45B	MERT-01
RM9-125A	9	9TH	45R&45B	MERT-01
RM9-135A	9	9TH	45R&45B	MERT-01
RM9-145A	9	9TH	45R&45B	MERT-01
RM9-155A	9	9TH	45R&45B	MERT-01
RMO10-115A	10	9TH	45R&45B	MERT-02
RMO10-125A	10	9TH	45R&45B	MERT-02
RMO10-135A	10	9TH	45R&45B	MERT-02
RMO10-145A	10	9TH	45R&45B	MERT-02
RMO10-145AT	10	9TH	45R&45B	MERT-02
RMO10-155A	10	9TH	45R&45B	MERT-02
RMO13-145A	13	12TH	45R&45B	MERT-01
RM09-115A	9	8TH	45R&45B	MERT-02
RM09-115B	9	8TH	45R&45B	MERT-03
RM09-115R	9	8TH	45R&45B	MERT-02
RM09-125A	9	8TH	45R&45B	MERT-02
RM09-125B	9	8TH	45R&45B	MERT-03
RM09-125R	9	8TH	45R&45B	MERT-02
RM09-135A	9	8TH	45R&45B	MERT-02
RM09-135B	9	8TH	45R&45B	MERT-03
RM09-135R	9	8TH	45R&45B	MERT-02
RM09-145A	9	8TH	45R&45B	MERT-02
RM09-145B	9	8TH	45R&45B	MERT-03
RM09-145R	9	8TH	45R&45B	MERT-02
RM09-155B	9	8TH	45R&45B	MERT-03
RMX10-115A	10	9TH	45R&45B	MERT-02
RMX10-115C	10	9TH	45R&45B	MERT-04
RMX10-125A	10	9TH	45R&45B	MERT-02
RMX10-125C	10	9TH	45R&45B	MERT-04
RMX10-135A	10	9TH	45R&45B	MERT-02
RMX10-135C	10	9TH	45R&45B	MERT-04
RMX10-145A	10	9TH	45R&45B	MERT-02
RMX10-145C	10	9TH	45R&45B	MERT-04
RMX10-145CT	10	9TH	45R&45B	MERT-04
RMX10-155A	10	9TH	45R&45B	MERT-02
RMX10-155C	10	9TH	45R&45B	MERT-04

LET. CODE	MAKE MODEL	NO. FWD. SP'DS	DIRECT DRIVE IN.	TEETH IN PTO DRIVER	PTO APPL. NO
-----------	------------	----------------	------------------	---------------------	--------------

## ZF (ZF/MERITOR) (Continued)

RMX10-165A	10	9TH	45R&45B	MERT-02
RMX10-165C	10	9TH	45R&45B	MERT-04
RMX10-165CT	10	9TH	45R&45B	MERT-04
RMX13-145A	13	12TH	45R&45B	MERT-01
RMX9-115B	9	8TH	45R&45B	MERT-03
RMX9-115R	9	8TH	45R&45B	MERT-02
RMX9-125A	9	8TH	45R&45B	MERT-02
RMX9-125B	9	8TH	45R&45B	MERT-03
RMX9-125R	9	8TH	45R&45B	MERT-02
RMX9-135A	9	8TH	45R&45B	MERT-02
RMX9-135B	9	8TH	45R&45B	MERT-03
RMX9-135R	9	8TH	45R&45B	MERT-02
RMX9-145A	9	8TH	45R&45B	MERT-02
RMX9-145B	9	8TH	45R&45B	MERT-03
RMX9-145R	9	8TH	45R&45B	MERT-02
RMX9-155B	9	8TH	45R&45B	MERT-03
RS10-115A	10	10TH	45R&45	MERT-01
RS10-125A	10	10TH	45R&45	MERT-01
RS10-135A	10	10TH	45R&45	MERT-01
RS10-145A	10	10TH	45R&45	MERT-01
RS10-155A	10	10TH	45R&45	MERT-01
RS9-115A	9	9TH	45R&45	MERT-01
RS9-125A	9	9TH	45R&45	MERT-01
RS9-135A	9	9TH	45R&45	MERT-01
RS9-145A	9	9TH	45R&45	MERT-01
RS9-155A	9	9TH	45R&45	MERT-01
RS09-115B	9	8TH	45R&45	MERT-03
RS09-125B	9	8TH	45R&45	MERT-03
RS09-135B	9	8TH	45R&45	MERT-03
RS09-145B	9	8TH	45R&45	MERT-03
RS09-155B	9	8TH	45R&45	MERT-03
RSX10-115A	10	9TH	45R&45	MERT-02
RSX10-115C	10	9TH	45R&45B	MERT-04
RSX10-125A	10	9TH	45R&45	MERT-02
RSX10-125C	10	9TH	45R&45B	MERT-04
RSX10-135A	10	9TH	45R&45	MERT-02
RSX10-135C	10	9TH	45R&45B	MERT-04
RSX10-145A	10	9TH	45R&45	MERT-02
RSX10-145C	10	9TH	45R&45B	MERT-04
RSX10-155A	10	9TH	45R&45	MERT-02
RSX10-155C	10	9TH	45R&45B	MERT-04
RSX10-165A	10	9TH	45R&45	MERT-02
RSX10-165C	10	9TH	45R&45B	MERT-04
RSX9-115B	9	8TH	45R&45	MERT-03
RSX9-115C	9	8TH	45R&45	MERT-03
RSX9-115R	9	8TH	45R&45	MERT-03
RSX9-125A	9	8TH	45R&45	MERT-02
RSX9-125B	9	8TH	45R&45	MERT-03
RSX9-125C	9	8TH	45R&45	MERT-03
RSX9-125R	9	8TH	45R&45	MERT-02
RSX9-135A	9	8TH	45R&45	MERT-02
RSX9-135B	9	8TH	45R&45	MERT-03
RSX9-135C	9	8TH	45R&45	MERT-03
RSX9-135R	9	8TH	45R&45	MERT-02
RSX9-145A	9	8TH	45R&45	MERT-02
RSX9-145B	9	8TH	45R&45	MERT-03
RSX9-145C	9	8TH	45R&45	MERT-03
RSX9-145R	9	8TH	45R&45	MERT-02
RSX9-155B	9	8TH	45R&45	MERT-03
RSX9-155C	9	8TH	45R&45	MERT-03
RSX9-165C	9	8TH	45R&45	MERT-03

