



Muncie[®]
Power
Products

FR66 SERIES POWER TAKE-OFF

PARTS LIST AND SERVICE MANUAL

NOTE: FOR UNITS BUILT PRIOR TO JUNE 2013

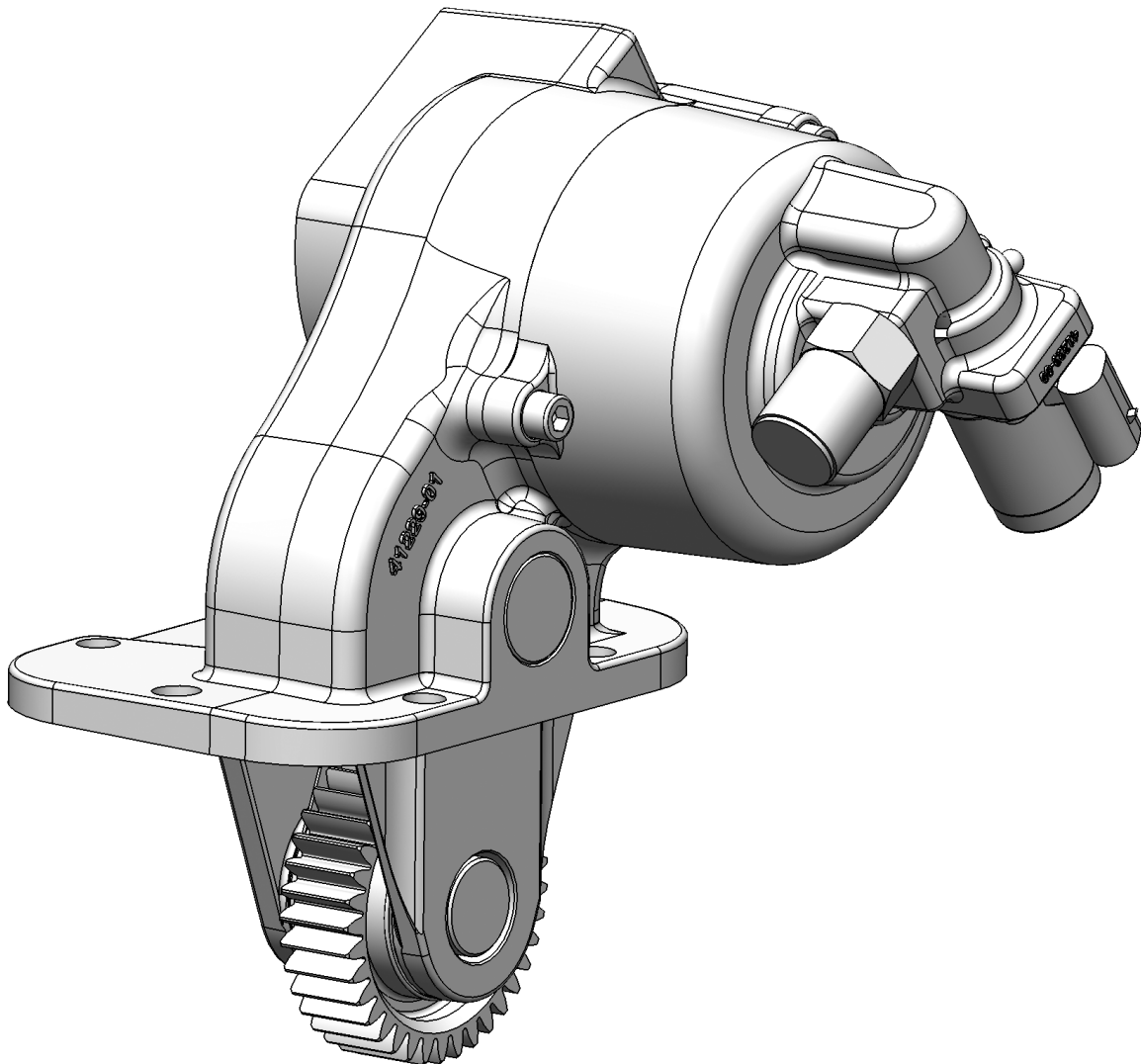

FR66 EXPLODED VIEWS

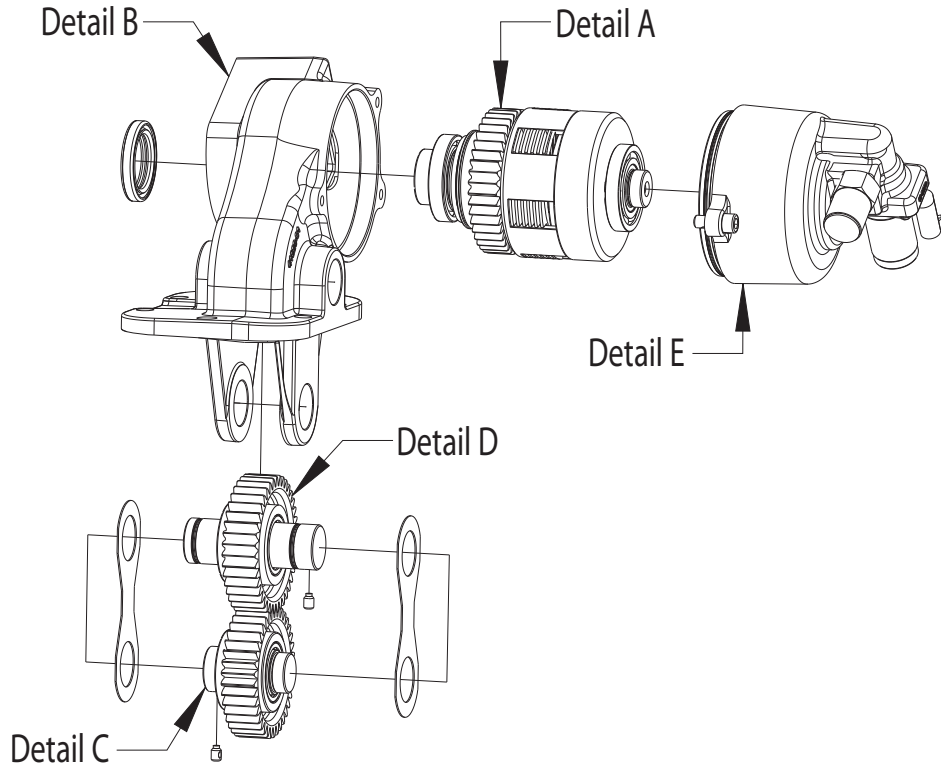

Detail A — Output Shaft Assembly

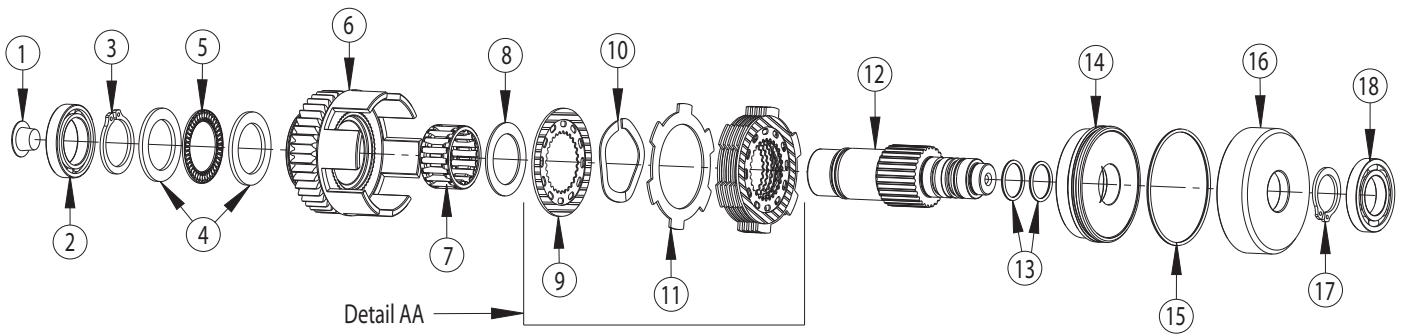

Detail AA — Clutch Pack Assembly (Disc Location)*

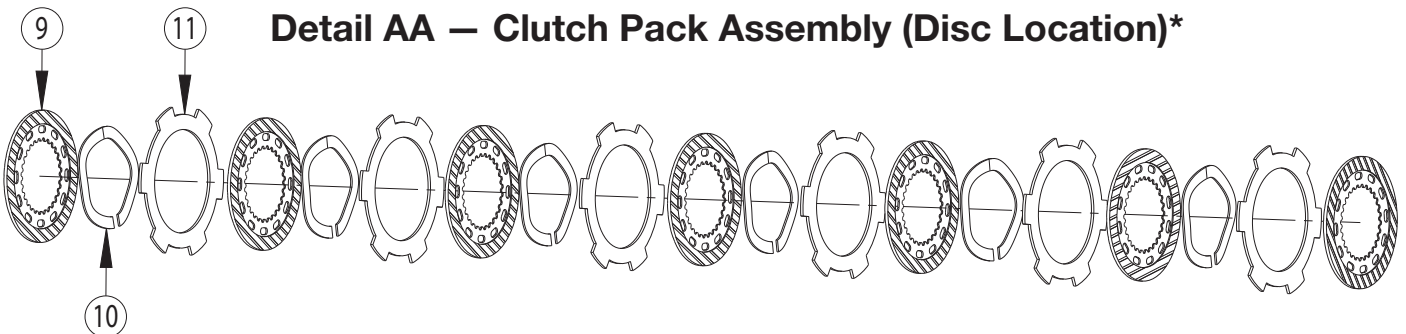

* The clutch pack assembly contains a friction disc followed by a spacer disc and a spring. The assembly should begin and end with a friction disc.

FR66 EXPLODED VIEWS

Detail B – PTO Housing

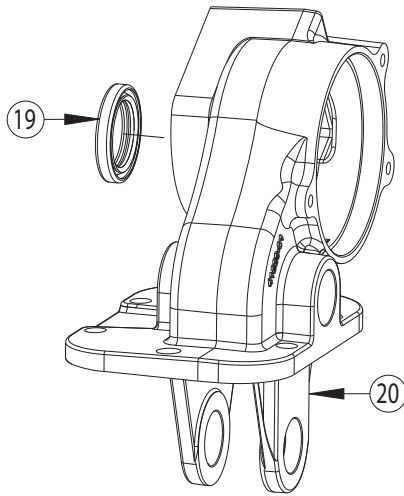

Detail C – Input Shaft Assembly

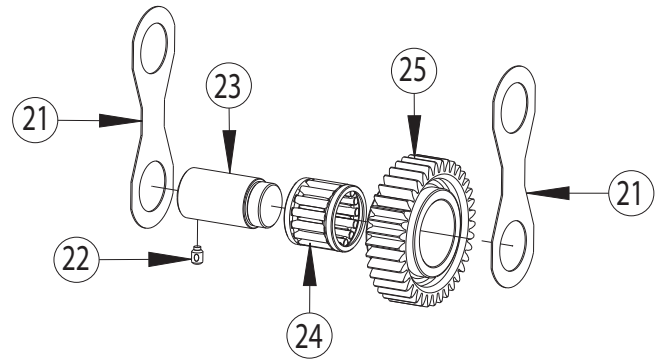

Detail D – Idler Shaft Assembly

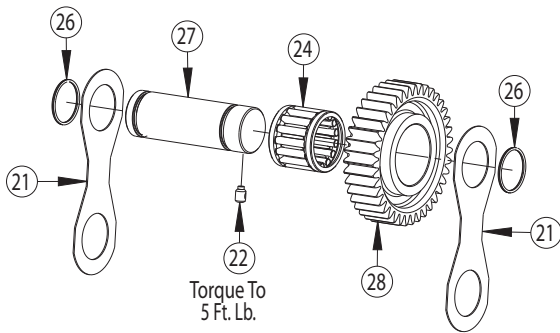

Detail E – End Cover Assembly

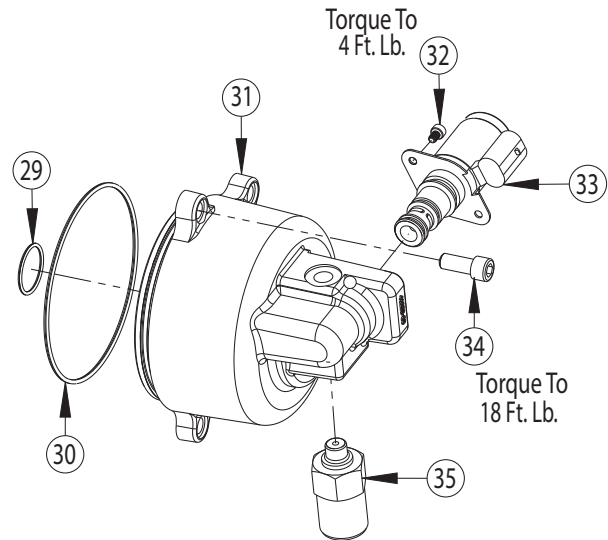

PARTS LIST AND DESCRIPTION

ITEM	QTY	PART NO.	DESCRIPTION
01	1	25T37387	Cap Plug
02	1	10T39147	Bearing
03	1	24T35480	Snap Ring
04	2	21T29017	Washer
05	1	10T37009	Thrust Bearing
06	1	02T41804	Output Gear
07	1	10T37008	Needle Bearing
08	1	21T37085	Washer
09	7	49T36259	Friction Disc
10	6	27T36286	Spring
11	6	49T36258	Spacer Disc
12	1	06T41493	Output Shaft "N"
	1	06T41494	Output Shaft "B"
13	2	12T39023	O-Ring
14	1	49T38881	Piston
15	1	12T36540	O-Ring
16	1	49T39022	Piston Cup
17	1	24T39182	Snap Ring

ITEM	QTY	PART NO.	DESCRIPTION
18	1	10T39072	Bearing
19	1	11T37790	Seal
20	1	01T41230	PTO Housing
21	2	10T41590	Thrust Plate
22	2	19T34789	Setscrew
23	1	07T41238	Input Idler Shaft
24	2	10T39145	Needle Bearing
25	1	03T41802	Input Idler Gear
26	2	12T35577	O-Ring
27	1	08T41236	Reverse Idler Shaft
28	1	04T41235	Reverse Idler Gear
29	1	12T36280	O-Ring
30	1	12T36279	O-Ring
31	1	15T41234	End Cover
32	2	19T40859	Capscrew
33	1	35T40860	Directional Control Valve
34	3	19T35237	Capscrew
35	1	30T60223	Switch
N.S.	1	25T41375	Plug
N.S.	1	26T01627	Woodruff Key – "B" Shaft

FR66 INSTALLATION KITS – 43TK5209

FR66 Electric/Hydraulic Shift System – “D”Activation Kit

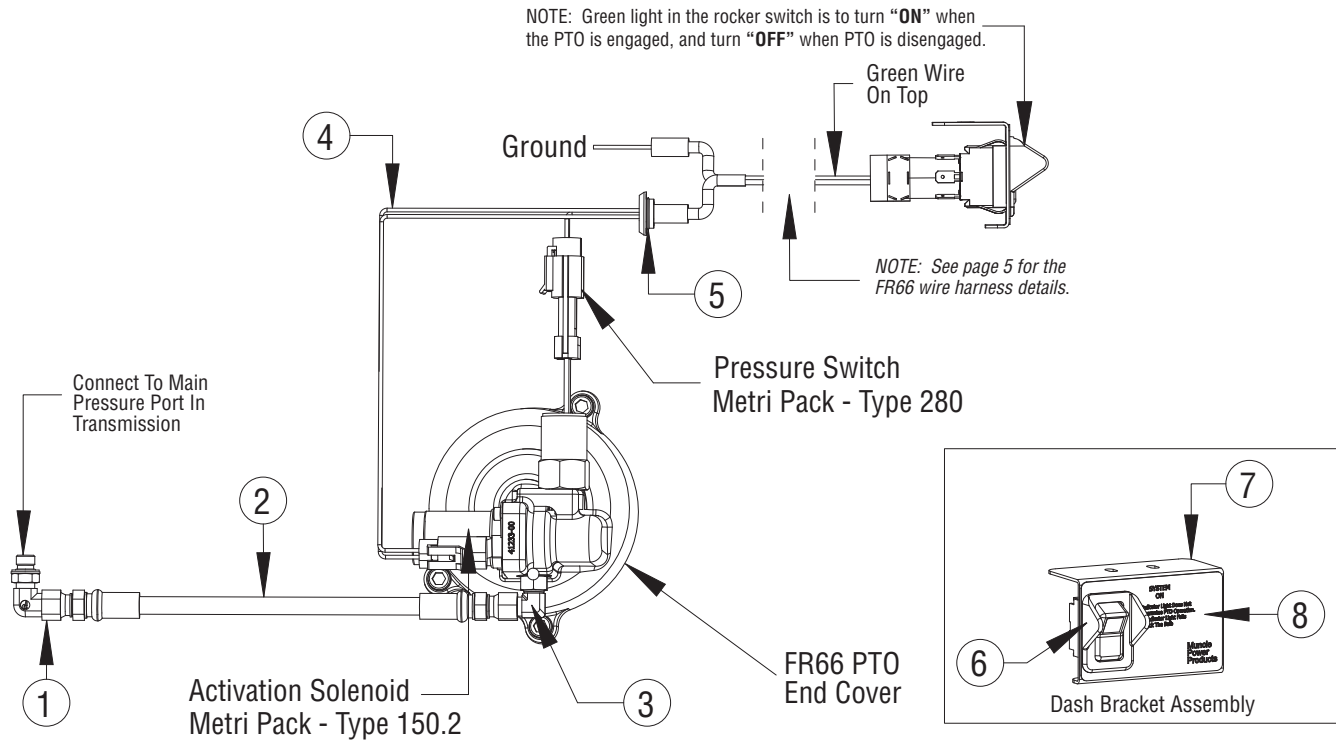

ITEM	QTY	PART NO.	DESCRIPTION
1	1	43T41572	Transmission Fitting (JIC-10mm Str.)
2	1	45T39186	17" Hose Assembly (JIC-JIC)
3	1	43M68014	JIC 90° Fitting
4	1	34T41671	FR66 Wire Harness
5	1	37T35674	Rubber Grommet
6	1	30T35687	Rocker Switch 12V
7	1	36MA1005	Switch Bracket
8	1	36T36271	Face Plate
9	2	20T37914	Metric Stud
10	2	22T39282	Spirallock Nut
11	4	20T37952	Step Stud
12	4	22T37605	Whiz-Lock Nut
N.S.	6	28T35442	Cable Ties
N.S.	1	36MK1007	Dash Bracket Bolt Kit

FR66 Bolt Kit Installation

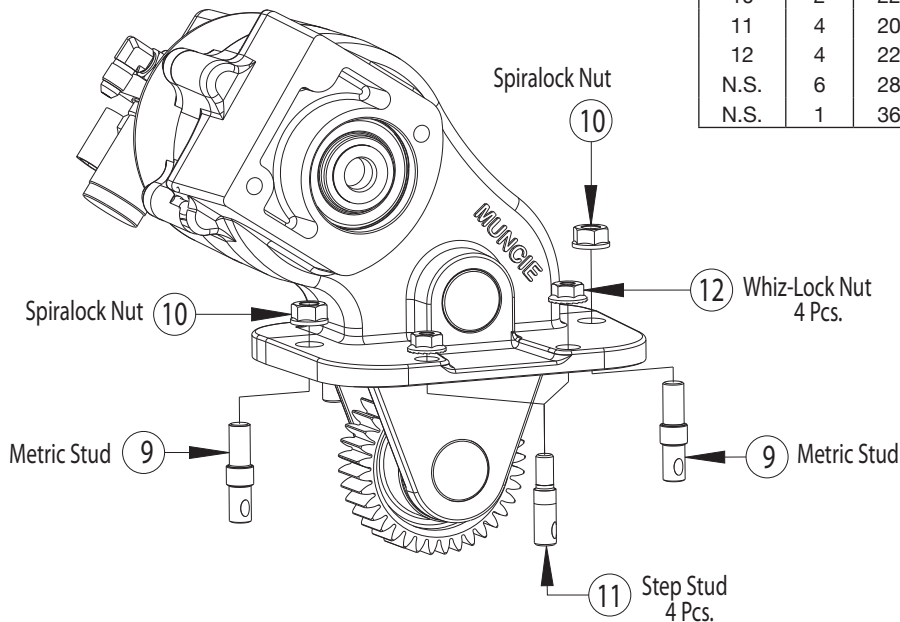

FORD 2011 – DIESEL ENGINE

FR66 “D” Shift Option Harness

FR66 Wire Harness - 34T41671

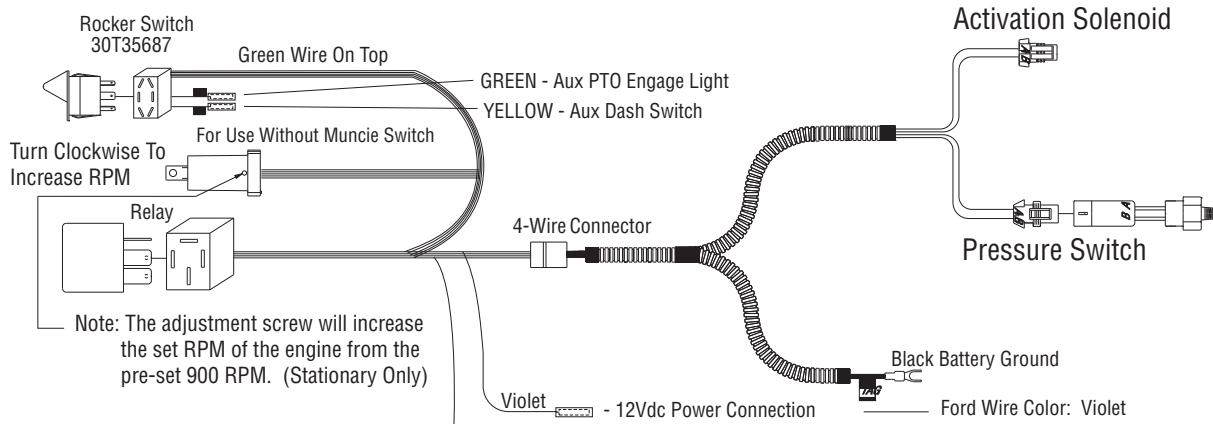

F-250/350/450/550 Diesel Engine PCM

Circuit Intent	Ford Wire Tag	PCM Pin No.	Circuit No.	Wire Color
Blue/White - Output	PTO_RELAY	C-11	CE326	Blue/White
Yellow/Green - Input (VPWR)	PTORS1	C-06	CE912	Yellow/Green (Stationary)
White/Brown - Ref. Voltage	PTOREF	C-55	LE434	White/Brown
Green - Input (Resistor)	PTO_RPM	C-08	CE914	Green
Gray/Violet - PCM Ground	PTORTN	C-22	RE327	Gray/Violet

FOR MOBILE USE: Use 34T41896 harness. Connect Blue/Gray wire to Ford Blue/Gray wire PTORS2 (Yellow/Green PTORS1 is not connected.) Other wiring is same as above.

MODEL NUMBER CONSTRUCTION

FR66 – F12 09 – D 3 N X

Model

Ford 6-Bolt – FR66

Transmission Gear

Ford 12.18P – F12

Ratio

0.90:1 – 09

Special Features

X – None

Output Type

B – 1-1/4" Rnd. Key**
N – 3/4" 11T Spline

Assembly Arrangement

3

Shift Type

D – Elec./Hyd. (Diesel)

** Driveline output is not recommended on 4x4 Chassis.

FR66 DIMENSIONS IN INCHES (MM)

“B” Output Option – 1-1/4" Round

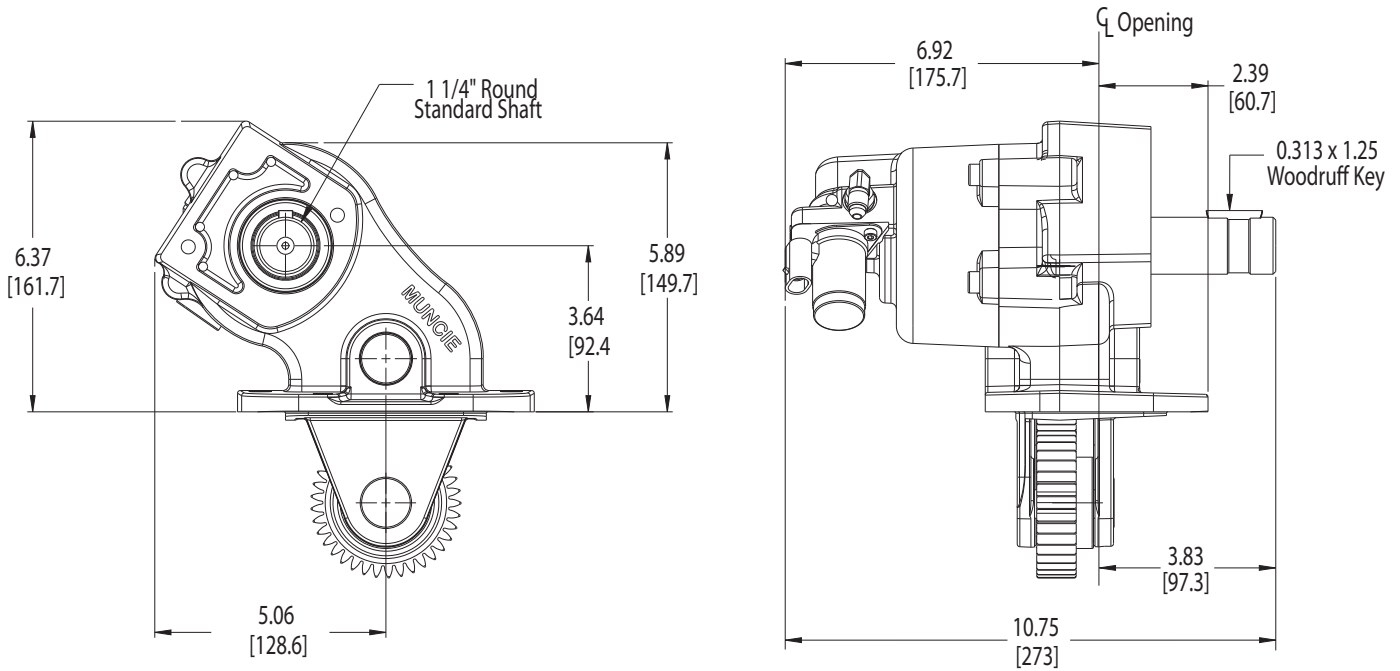

“N” Output Option – 3/4" - 11T

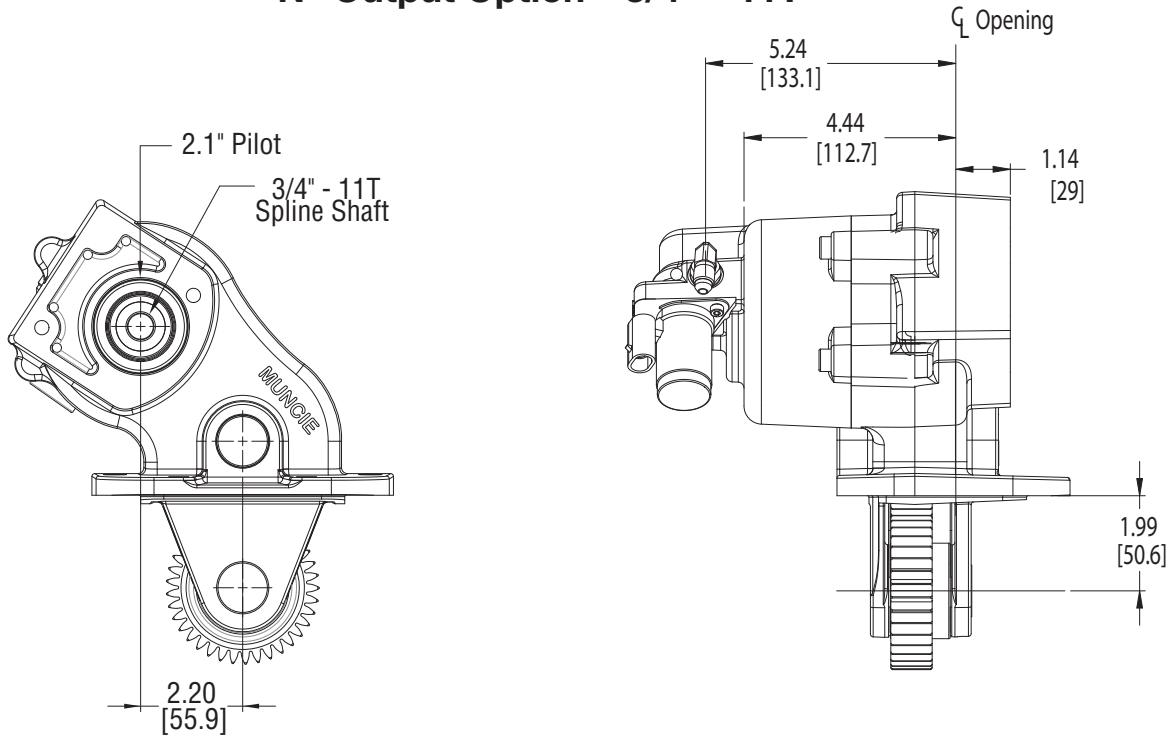



**Muncie[®]
Power
Products**

A Member of the Interpump Group

SP10-06 (Rev. 06-19)

201 East Jackson Street • Muncie, Indiana 47305
800-367-7867 • Fax 765-284-6991 • info@munciepower.com • www.munciepower.com
Specifications are subject to change without notice. Visit www.munciepower.com
for warranties and literature. All rights reserved. © Muncie Power Products, Inc. (2010)