

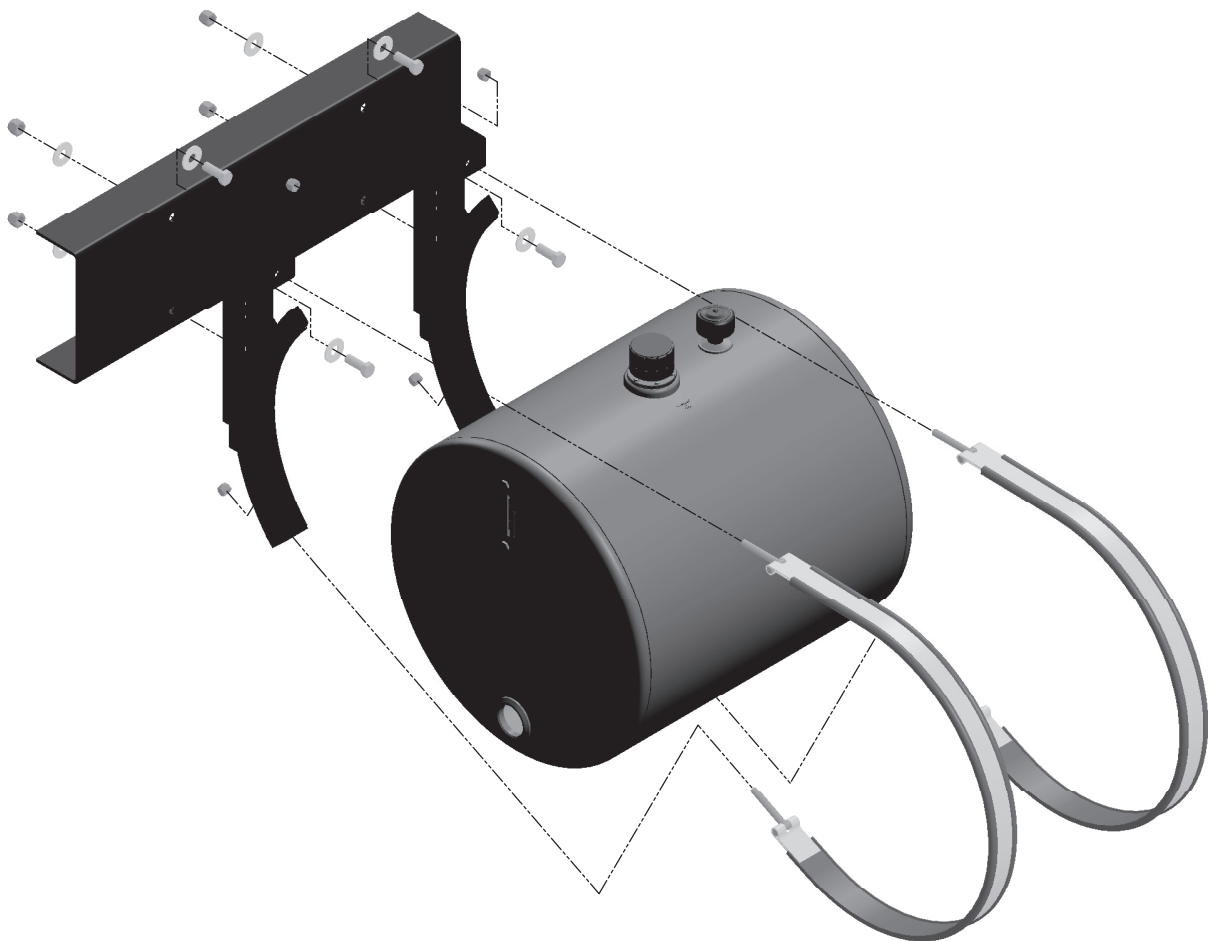

ALUMINUM & STEEL ROUND SIDE-MOUNT TANKS 25 / 35 / 50 / 75 / 100 GALLON

INSTALLATION INSTRUCTIONS AND SERVICE PARTS



Service Parts - 3 Tank Options Shown

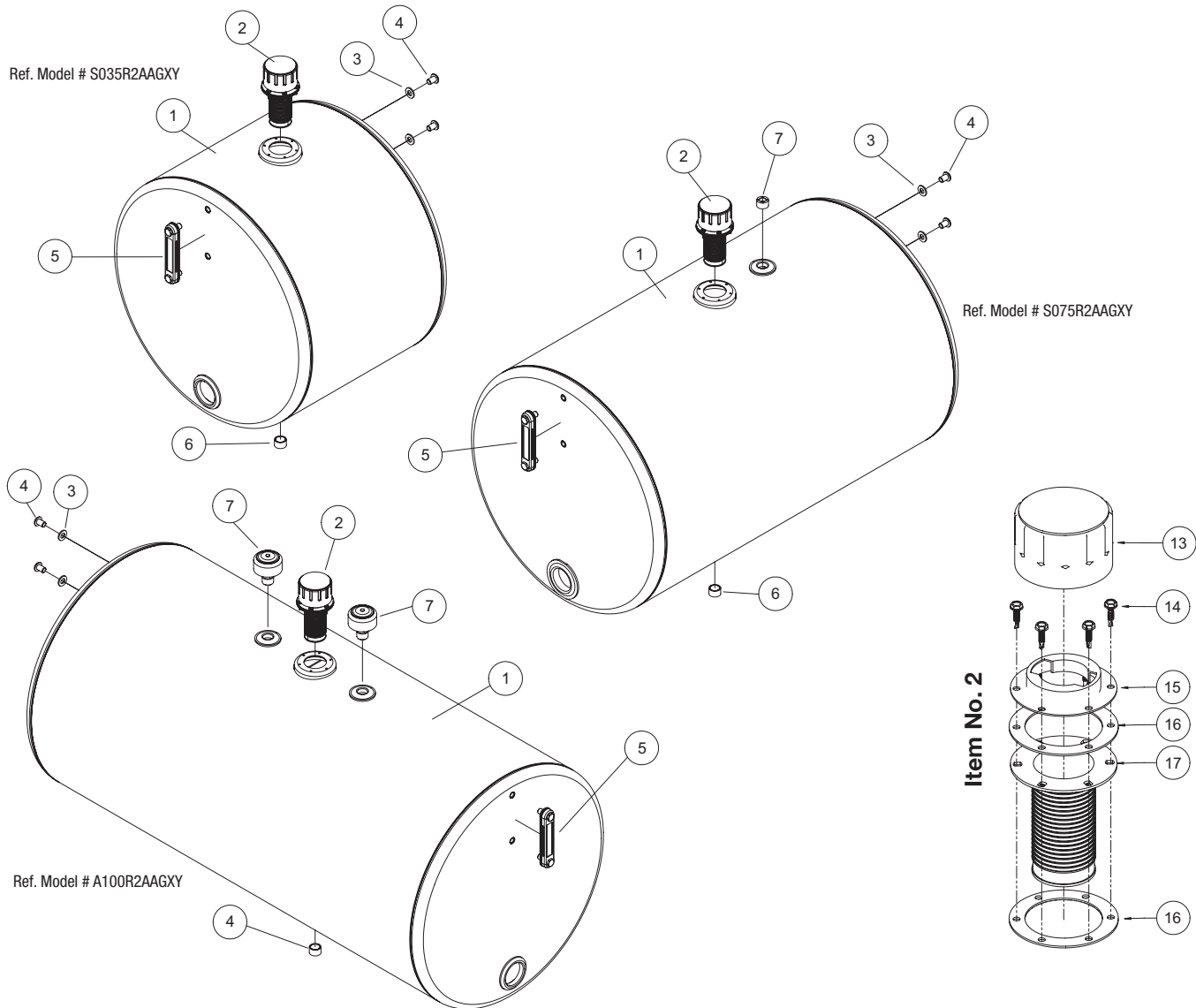

SERVICE PARTS LIST			
ITEM #	DESCRIPTION	QTY	PART #
1	Tank Body (Steel or Aluminum) ¹	1	N/A
2	Breather Cap Assembly	1	BC50FSGK-A
3	O-Rings for Sight Gauge	2	13M43055
4	Button Head Screw	2	19M43056
5	Sight/ Temp Gauge - Standard	1	31T36377
6	Magnetic Plug	1	55T36629
7	¾" NPT Plug ²	1 ²	HHPP12Z
	¾" Vent Breather ²	2 ²	55T36394
N.S.	Diffuser - Standard	1	8020590

SERVICE PARTS LIST			
ITEM#	DESCRIPTION	QTY	PART#
N.S.	High Flow Diffuser - Optional	1	43T37610
N.S.	2" x 1¼" Reducer Bushing - Standard	1	8020591
N.S.	2" x 1½" Reducer Bushing - Optional	1	43T37609
N.S.	2" NPT Pipe Plug	1	HHPP-32Z
13	Breather Cap	1	BC-50
14	10-32 Screws w/ O-ring	6	19T36674
15	Low Neck Breather Flange	1	56T36398
16	Breather Flange Gasket	2	13T36399
17	Strainer Basket	1	56T36400

Notes: 1. Tank Body Not Sold Individually.

2. No Plug or Breather on 25 Gallon Tanks. One Plug Standard on 50 and 75 Gallon Steel Tanks. Two Plugs Standard on 100 Gallon Steel Tank. One Breather Standard on 50 and 75 Gallon Aluminum, Two Breathers Standard on 100 Gallon Aluminum Tanks.

Installation Kits

STANDARD INSTALLATION KITS			TANK SIZE:		
			25/35/50	75	100
			INSTALLATION KIT #		
			AMK-624-C	AMK-624-C3	AMK-624-C ³
ITEM#	DESCRIPTION	PART #	QUANTITY(S)		
18	"J" Brackets - Powder Coated, Rubber Lined ⁴	N/A	2	3	4 ³
19	2" Wide Carbon Steel Strap Assem. With Rubber (Two nylock™ nuts included per strap)	ASA355	2	3	4 ³

OPTIONAL - STAINLESS INSTALLATION KITS			TANK SIZE:		
			25/35/50	75	100
			INSTALLATION KIT #		
			AMK-624-S	AMK-624-S3	AMK-624-S ³
ITEM#	DESCRIPTION	PART #	QUANTITY(S)		
18	"J" Brackets - Powder Coated, Rubber Lined ⁴	N/A	2	3	4 ³
19	2" Wide Stainless Steel Strap Assem. With Rubber (Two nylock™ included per strap)	ASA355-S	2	3	4 ³

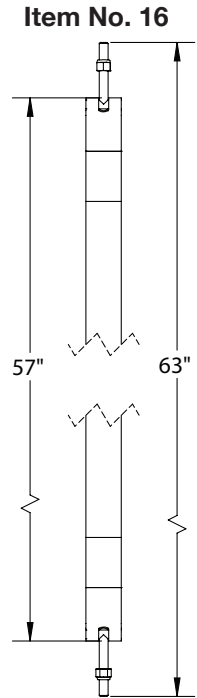

Notes: 3. Must Order A Quantity of "2" AMK-624-C or "2" AMK-624-S Installation Kits for the 100 Gallon Tanks.
 4. "J" Brackets Not Sold Individually, Must Order Complete Installation Kit.

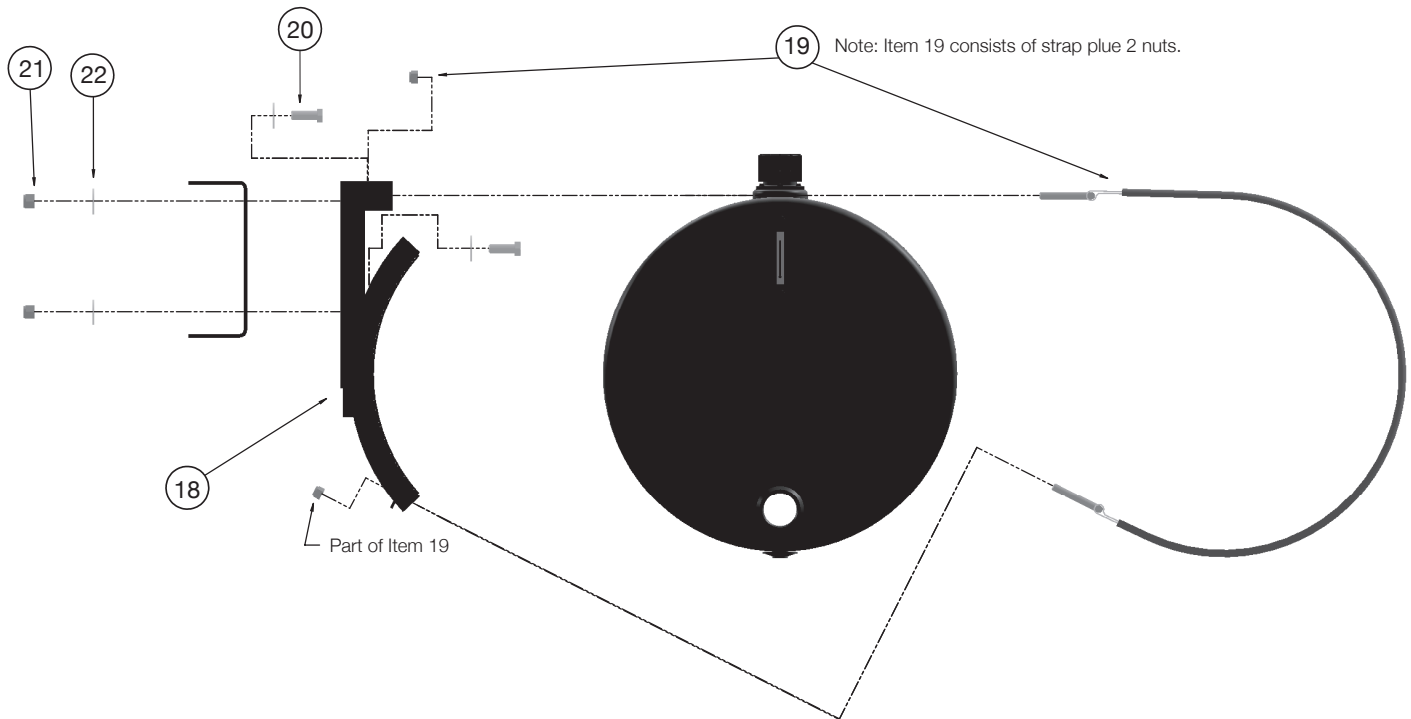

ADDITIONAL INSTALLATION COMPONENTS ⁵					
ITEM#	DESCRIPTION	PART #	QTY (PER TANK SIZE)		
			25/35/50	75	100
20	5/8" Bolts	N/A	4	6	8
21	5/8" Nylock™ Nuts	N/A	4	6	8
22	5/8" Washers	N/A	8	12	16

Note: 5. Additional Installation Components to be supplied by installer. (Use minimum of 5/8" Grade 8 Bolts.)

Installation Instructions:

1. Position the top of the cradle bracket flush with truck frame rail.
2. Use the "J" bracket as a template to determine where to drill the required bolt holes in the frame.

Note 6: Bracket tops must mount flush with the top of the frame rails with no obstructions.

Note 7: Brackets should be placed within 2" from ends of tank, 75 gallon tanks require an extra bracket (and strap) placed on either side of fill cap, at least 1/2" from weld. 100 gallon tanks require two extra brackets (and straps), spaced evenly and at least 1/2" from weld.

3. Attach brackets to frame rail with the 5/8" grade 5 bolts, torque to between 128 ft.lbs. (Dry Plated) and 170 ft.lbs. (Dry Non-Plated) (2 bolts per bracket needed).
4. Place tank against brackets and firmly tighten nuts to straps (not more than 25 ft.lbs. of torque).
5. Install the reducer bushing and return line diffuser into the work ports. A thread sealant is recommended (Do not use Teflon® tape). The reducer bushing and diffuser can be fitted into either port for ease of installation but must be properly hooked up to the pump.
6. Install plumbing. All plumbing and fitting connections attached to tanks must be properly supported into same moving plane as the tank in order to keep plumbing and fittings from creating a metal fatigue fracture outside of port weld. We suggest using a hose support mount.

Warning: DO NOT use Teflon® tape during installation.

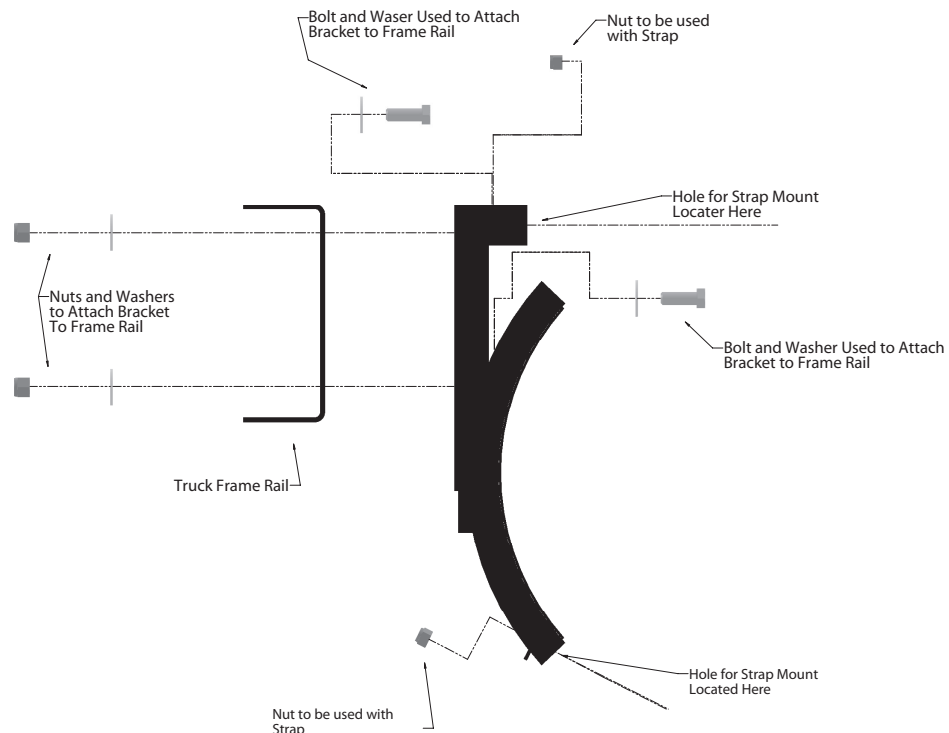

SP13-01 (Rev1-14) Printed in the U.S.A
© Muncie Power Products, Inc. 2013

Muncie Power Products, Inc. Member of the Interpump Hydraulics Group
General Offices and Distributor Center • P.O. Box 548 • Muncie, IN 47308-0548
(765) 284-7721 • FAX (765) 284-6991 • E-mail info@munciepower.com
Web site <http://www.munciepower.com>
Drive Products, Exclusive Agents for Canada, ISO Certified by an Accredited Registrar