



Muncie<sup>®</sup>  
Power  
Products

# RM SERIES REAR MOUNT POWER TAKE-OFF

---

PARTS LIST AND SERVICE MANUAL

---

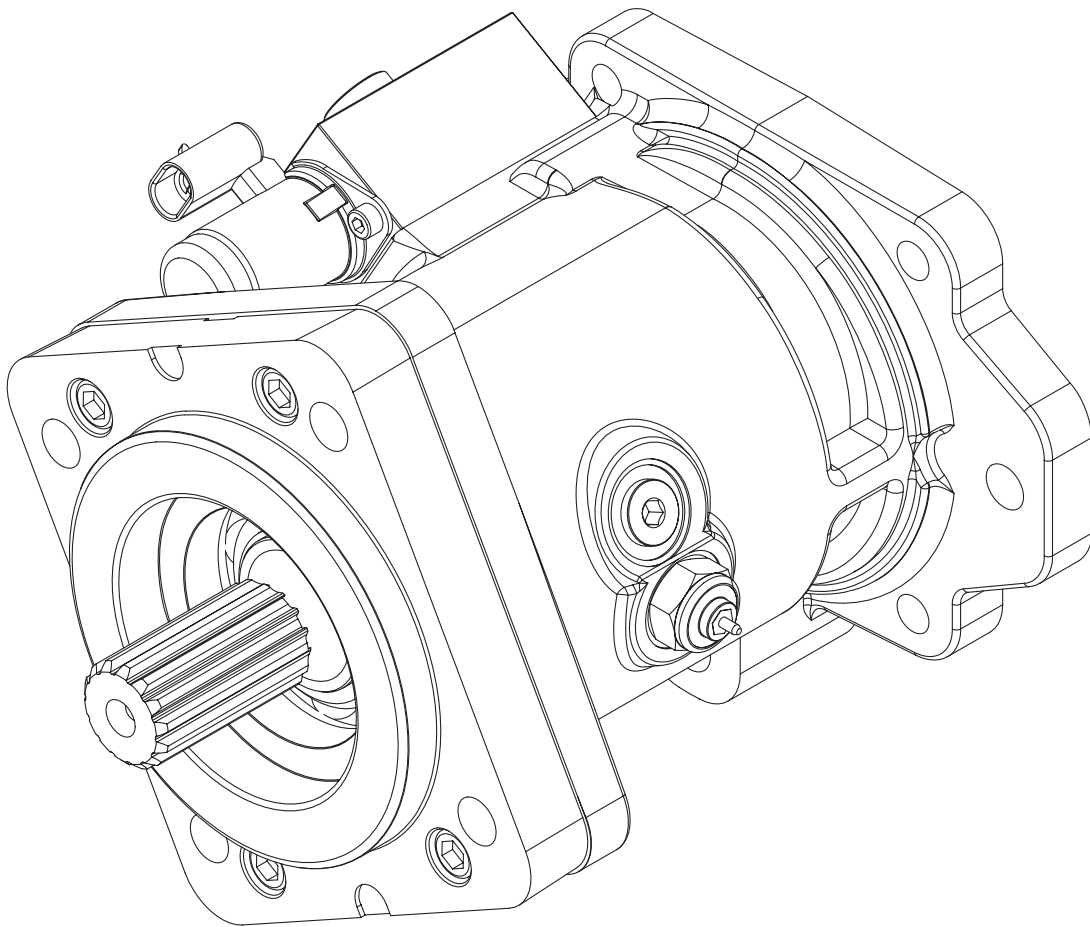



# RM SERIES PTO EXPLODED VIEWS

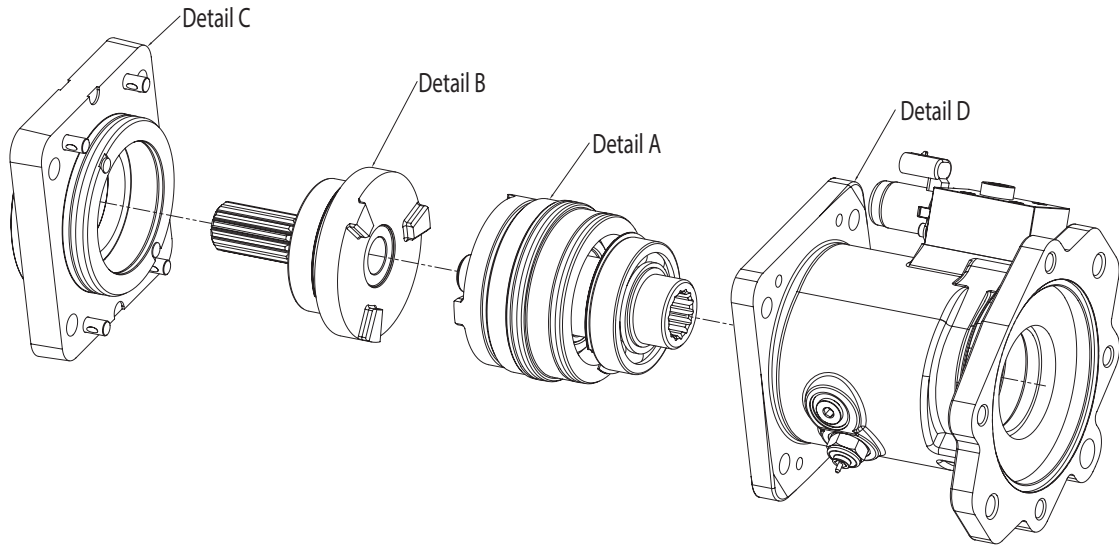

## DETAIL A – OUTPUT SHAFT ASSEMBLY

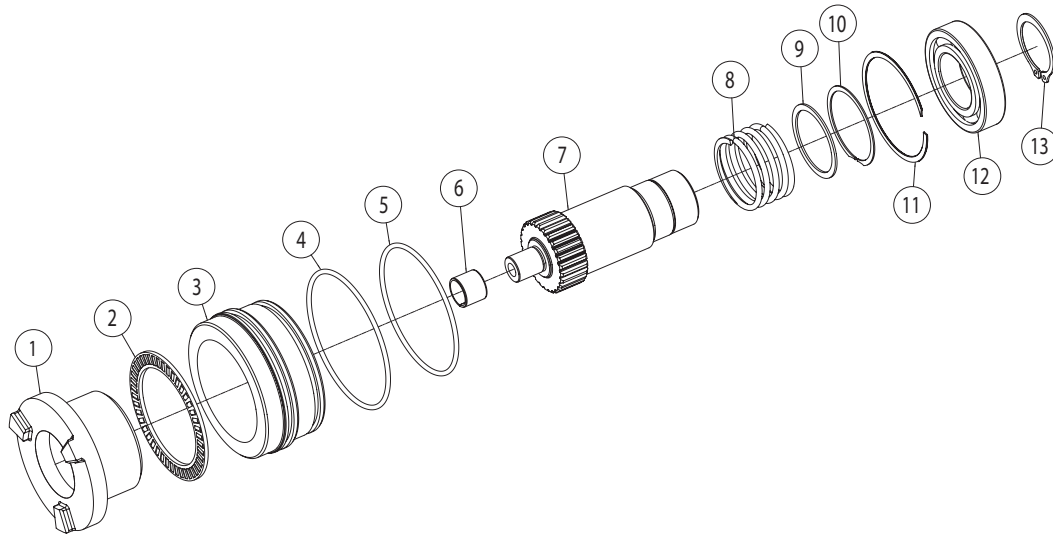

ITEM	QTY	PART NO	DESCRIPTION	
1	1	49T42439	Clutch, Sliding Collar	
2	1	10T42424	Bearing, Thrust	
3	1	49T42440	Clutch Piston	
4	1	12T42427	O-Ring, Viton	
5	1	12T36472	O-Ring, Viton	
6	1	49T42910	Bushing	
7	1	06T42422	Shaft, Output ("CC" & "X4")	
		1	06T43194	Shaft, Output ("BB")
8	1	27T42437	Spring	
9	1	21T42435	Washer	
10	1	24T42436	Retaining Ring	
11	2	24T42735	Retaining Ring	
12	2	10T35775	Ball Bearing Single Row, Radial	
13	2	24T38347	Retaining Ring - External	

## DETAIL B - INPUT SHAFT ASSEMBLY

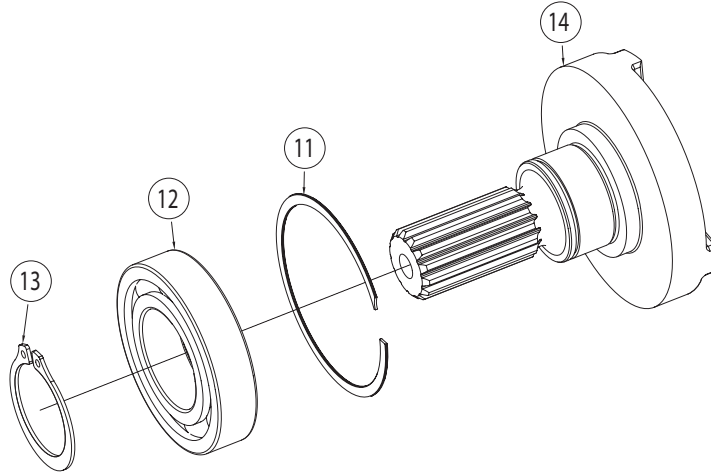

ITEM	QTY	PART NO	DESCRIPTION
11	2	24T42735	Retaining Ring
12	2	10T35775	Ball Bearing Single Row, Radial
13	2	24T38347	Retaining Ring - External
14	1	07T42423	Shaft, Input

## DETAIL C - COVER ASSEMBLY

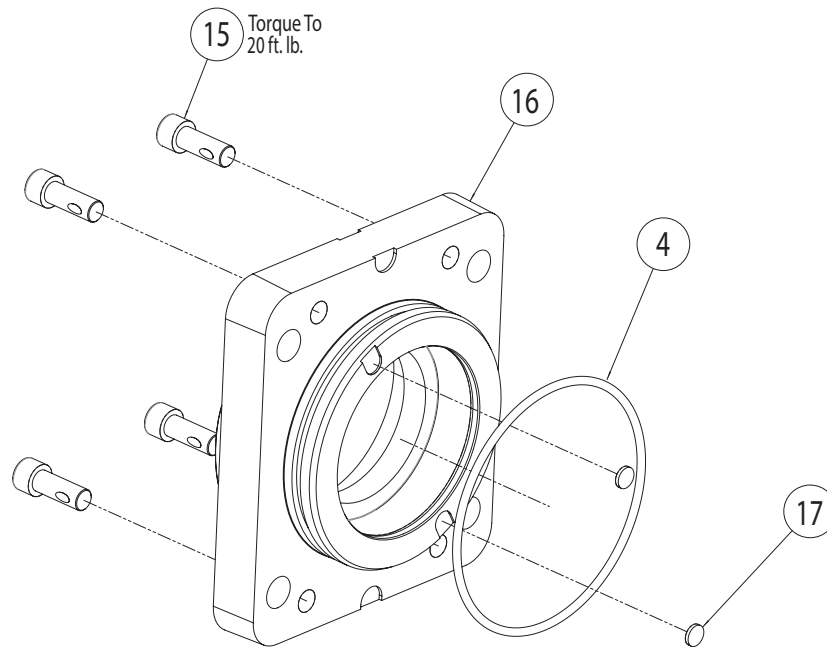

ITEM	QTY	PART NO	DESCRIPTION
4	1	12T42427	O-Ring, Viton
15	4	19T39418	Socket Head Cap Screw
16	1	15T42431	Cover
17	2	49T43209	Magnet

# DETAIL D – HOUSING ASSEMBLY

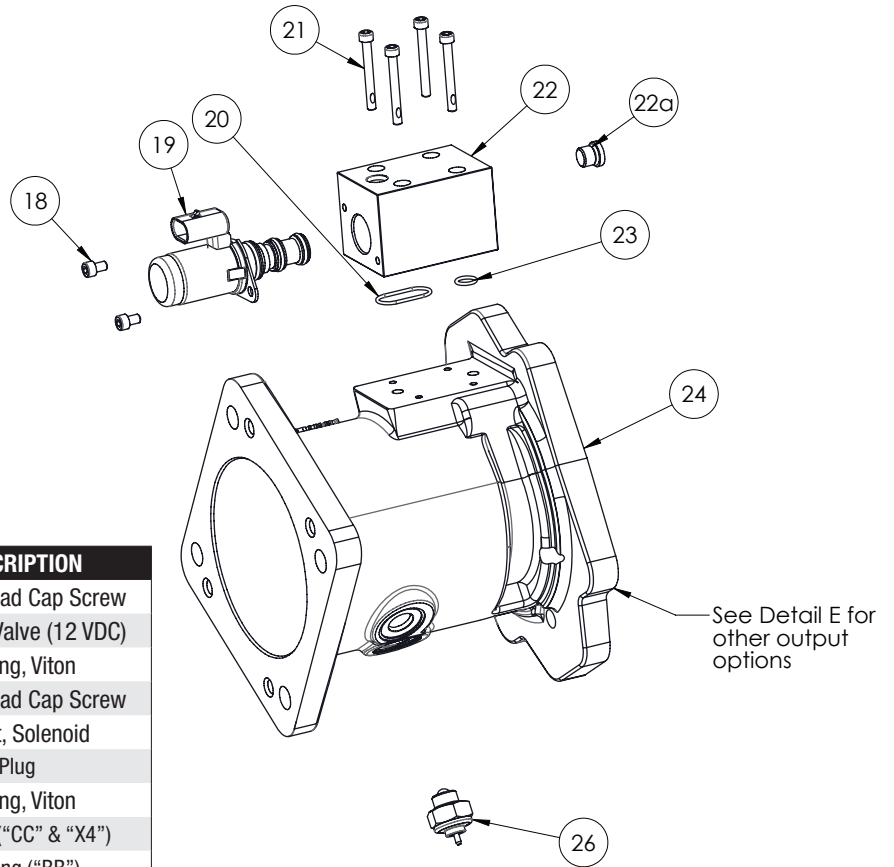

ITEM	QTY	PART NO	DESCRIPTION
18	2	19T40859	Socket Head Cap Screw
19	1	35T40860	Solenoid Valve (12 VDC)
20	1	12T36280	O-Ring, Viton
21	4	19T64181	Socket Head Cap Screw
22	1	35T62871	Mount, Solenoid
22a	1	25T41463	Plug
23	1	12T36881	O-Ring, Viton
24	1	01T42892	Housing ("CC" & "X4")
	1	01T42421	Housing ("BB")
26	1	30T38111	Indicator Switch N.C.

# DETAIL E – "X4" OUTPUT OPTION

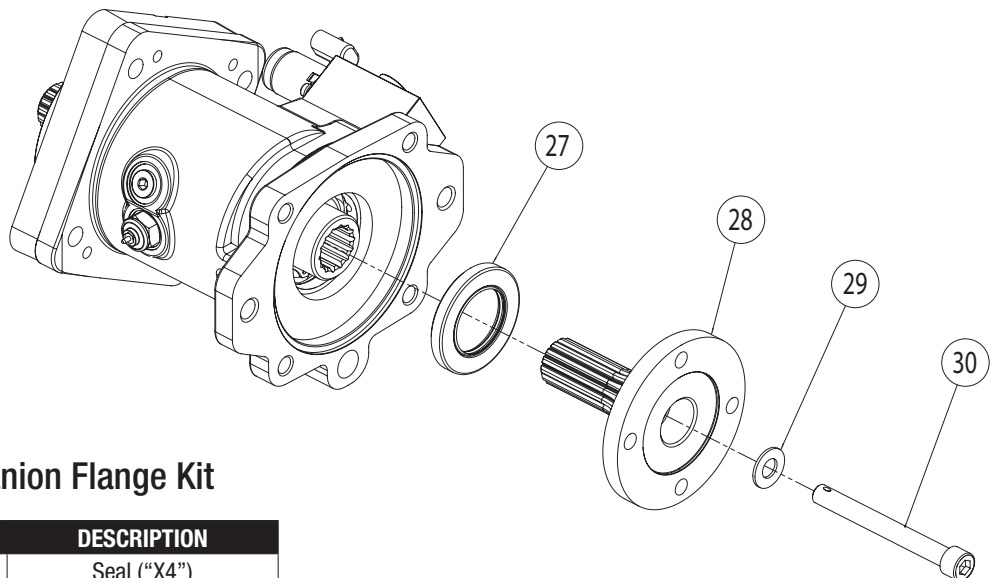

## 14TK5664 Companion Flange Kit

ITEM	QTY	PART NO	DESCRIPTION
27	1	11T37795	Seal ("X4")
28	1	14T42428	Flange, Companion ("X4")
29	1	21T43218	Washer ("X4")
30	1	19T42900	Capscrew ("X4")

# INSTALLATION KIT - 48TK5469

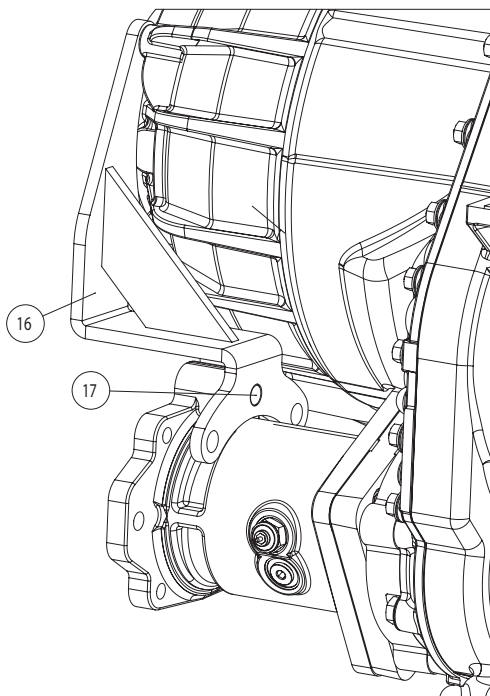
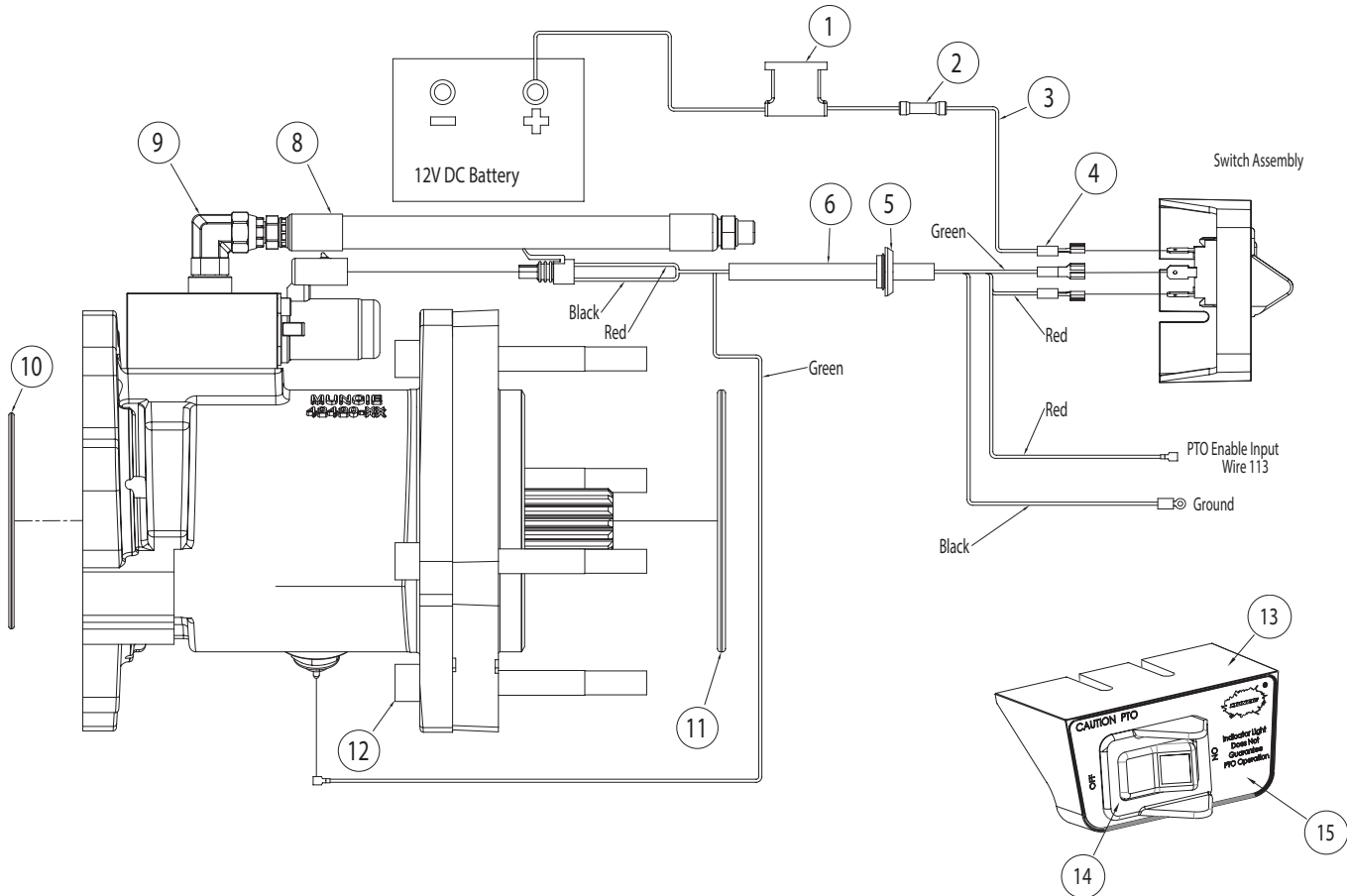

## KIT 48TK5469 (BB, GB Output Option)

ITEM	QTY	PART NO	DESCRIPTION
1	1	33T36299	Fuse Assembly
2	1	34M18002	Butt Splice
3	6 FT	37T42506	Wire
4	1	34M18250	Female Spade Connector
5	1	37T35674	Grommet
6	1	34T43217	Wire Harness
8	1	45T43222	Hose Assembly
9	1	43T42792	Elbow Fitting
10	1	12T36279	O-Ring (SAE B Flange)
11	1	12T36054	O-Ring
12	4	19T43221	Cap Screw
13	1	36T42362	Bracket
14	1	30T35687	Rocker Switch
15	1	36T42380	Face Plate for Switch
16	1	58T43264	Mounting Bracket
17	1	26T43265	Mounting Bracket Pin
18	2	19T43353	Bracket Screw
19	2	21T43351	Washer, Bracket Screw
N.S.	1	36MK1007	Bolt Kit
N.S.	1	36MK3841	Safety Labels

## KIT 48TK6333 (CC Output Option)

Same as above except:  
Item 10 1 12T43349 O-Ring

# MODEL NUMBER CONSTRUCTION

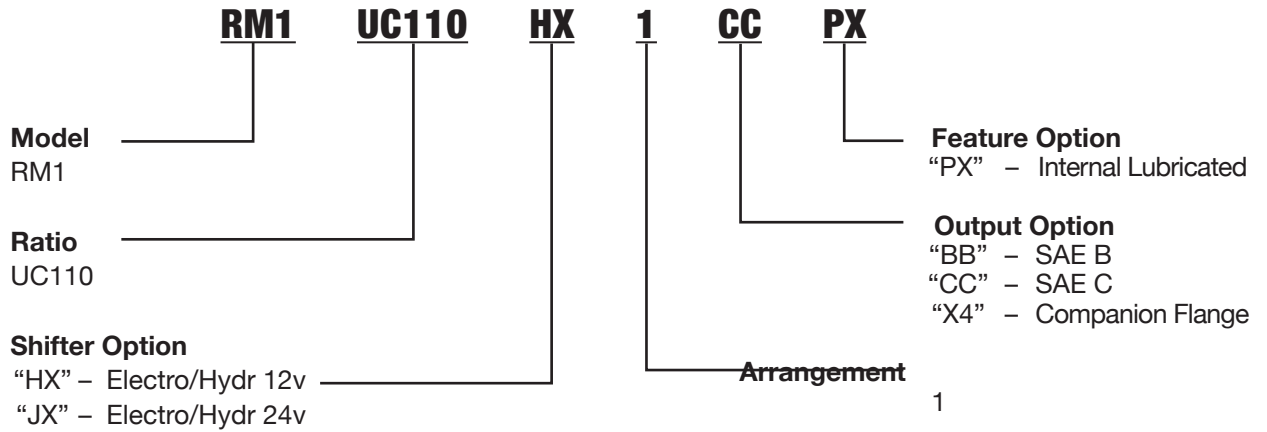

## OUTPUT COVER KITS

### 16TK5504 SAE-C/X4\* Cover Kit

ITEM	QTY	PART NO	DESCRIPTION
1	1	16T43315	Cover
2	4	HB113	Lock Washer
3	4	HB119	½" Capscrew
4	1	12T34003	O-Ring

\* To Use, remove companion flange

### 16TK5507 SAE-B Cover Kit

ITEM	QTY	PART NO	DESCRIPTION
1	1	16T43314	Cover
2	4	HB113	Lock Washer
3	4	HB119	½" Capscrew
4	1	12T43185	O-Ring

# DIMENSIONS IN INCHES (MM)

## “UC1” INPUT OPTION - SAE “C” SHAFT

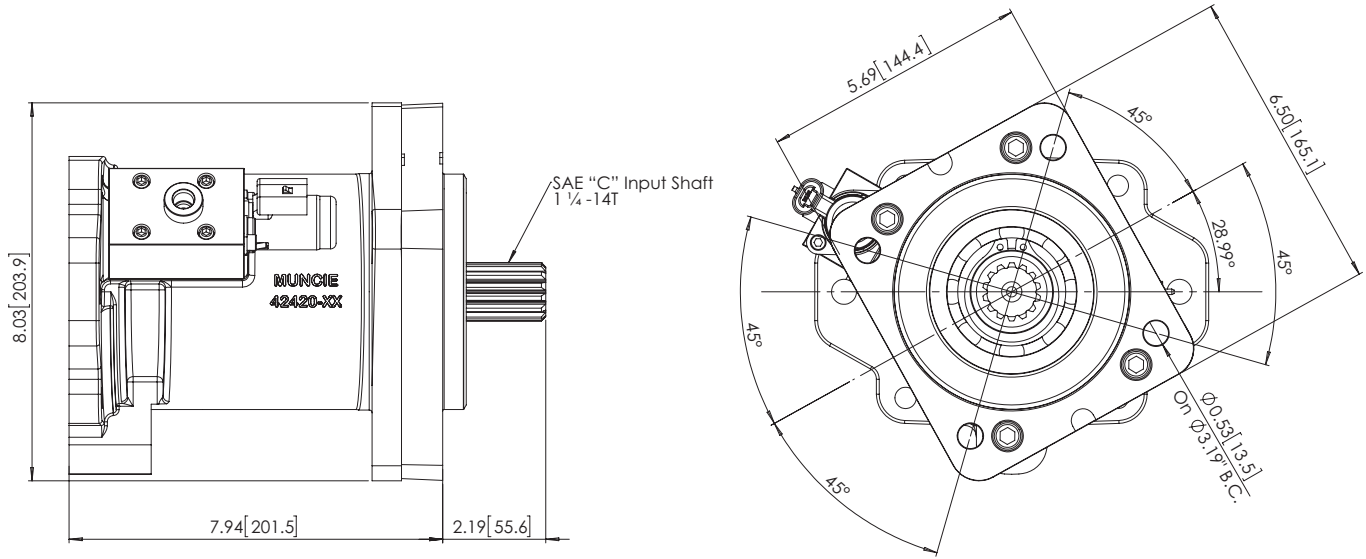

## “BB” OUTPUT OPTION – SAE “B” 2- AND 4-BOLT MOUNTING FLANGE WITH 7/8"-13T SHAFT

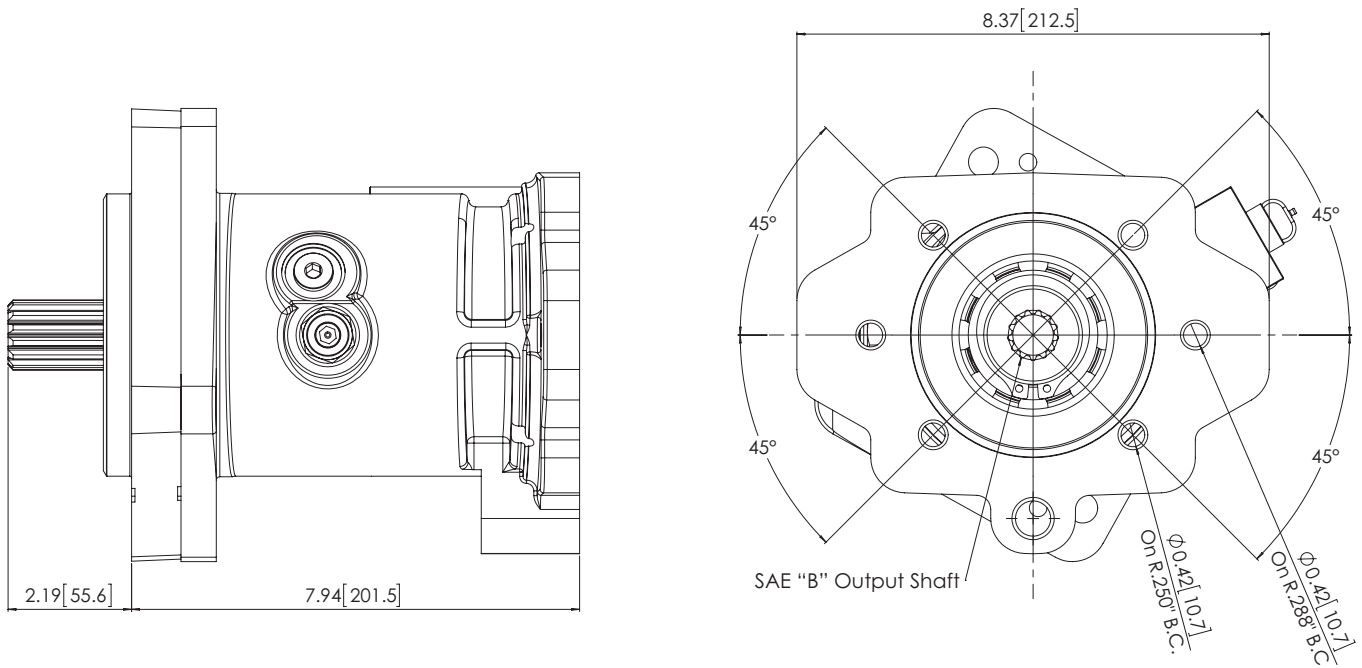



# DIMENSIONS IN INCHES (MM)

## “CC” OUTPUT OPTION – SAE “C” 2- AND 4-BOLT MOUNTING FLANGE WITH 1¼"-14T SHAFT

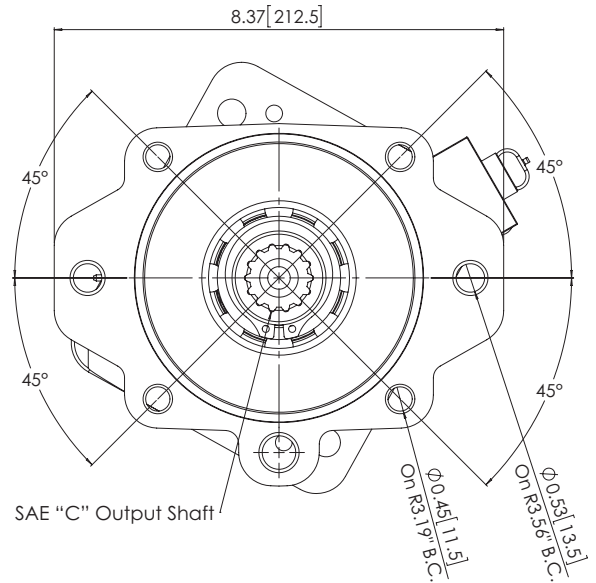
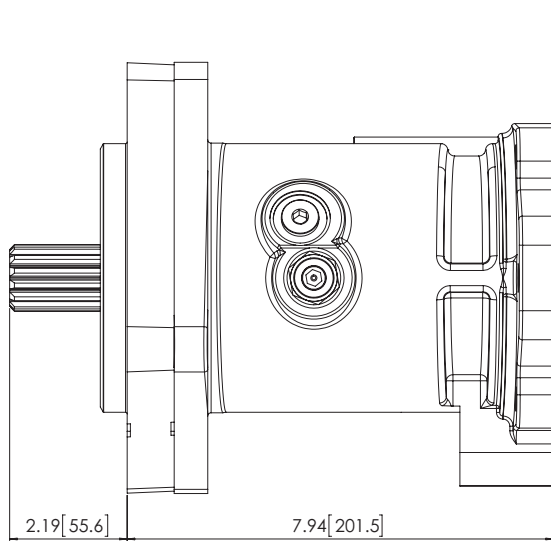

## “X4” OUTPUT OPTION – 1410 COMPANION FLANGE MOUNTED TO 1¼"-14T SHAFT

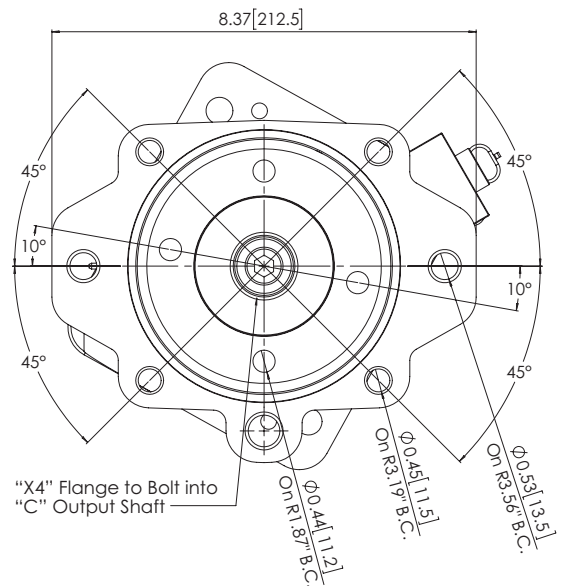
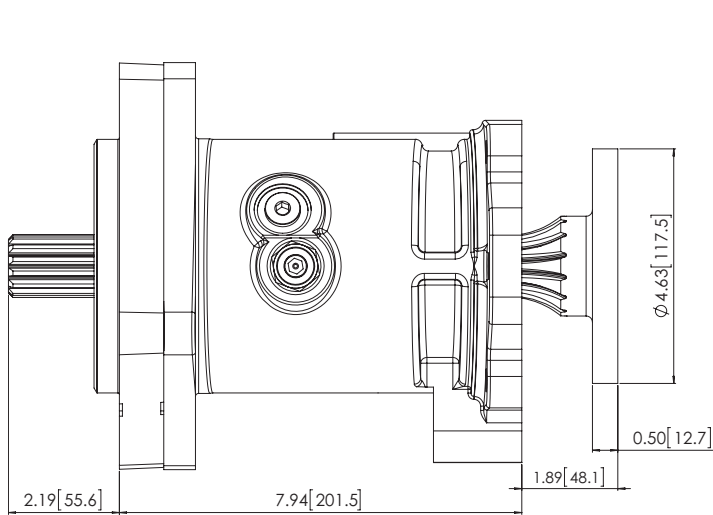

# RM1 DISASSEMBLY AND REASSEMBLY

(REFERENCE EXPLODED VIEWS ON PAGES 3, 4, 5)

## Disassembly Procedure

1. Remove the bolts from solenoid mount (22) and remove solenoid from housing (24).
2. Remove the bolts (15) and remove cover (16) from housing (24). Ensure that the magnets (17) are not lost when separating cover and housing.
3. Remove the snap ring (13) from the input shaft (14). Remove input shaft (14) from bearing (12) and cover (16).
4. Remove the snap ring (13) from the output shaft (7).
5. Remove shaft (7) from housing (24) and output assembly. Remove clutch sliding collar (1), thrust bearing (2), and clutch piston (3) from housing (24).

## Reassembly Procedure

1. Place O-Rings (4) and (5) in grooves on clutch piston (3).
2. Slide thrust bearing (2) onto clutch collar (1).
3. Slide clutch piston (3) onto clutch collar (1).
4. Install spring (8), washer (9), retaining rings (10)(11), and ball bearing (12). Install snap ring (13) on end of output shaft (7).
5. Reassemble clutch collar (1) and output shaft (7).
6. Place retaining ring (11) and bearing (12) on input shaft (14).
7. Install snap ring (13) on end of input shaft (14).
8. Replace input and output assemblies into housings (16)(24).
9. Fasten housings together with bolts (15) and torque to 20 ft.lb.
10. Reattach solenoid mount (22) using screws (21). Torque to 3 ft.lb.

# NOTES



**Muncie<sup>®</sup>  
Power  
Products**

*A Member of the Interpump Group*

SP15-02 (Rev. 09-18)

---

201 East Jackson Street • Muncie, Indiana 47305  
800-367-7867 • Fax 765-284-6991 • [info@munciepower.com](mailto:info@munciepower.com) • [www.munciepower.com](http://www.munciepower.com)  
Specifications are subject to change without notice. Visit [www.munciepower.com](http://www.munciepower.com)  
for warranties and literature. All rights reserved. © Muncie Power Products, Inc. (2015)