



Muncie®
Power
Products

82 SERIES POWER TAKE-OFF

PARTS LIST AND SERVICE MANUAL

FOR UNITS BUILT PRIOR TO NOVEMBER 2017

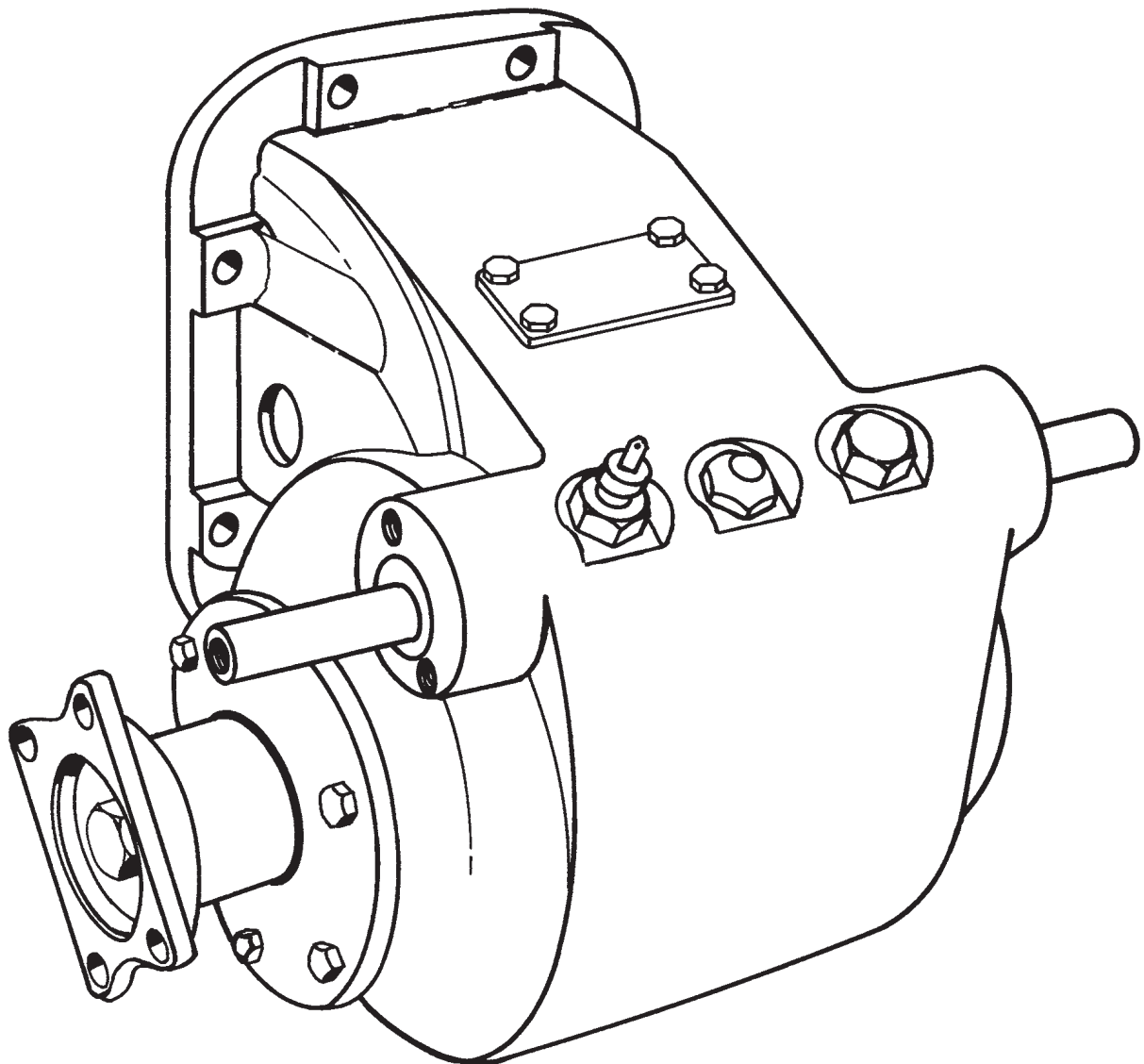

82 SERIES PTO EXPLODED VIEW

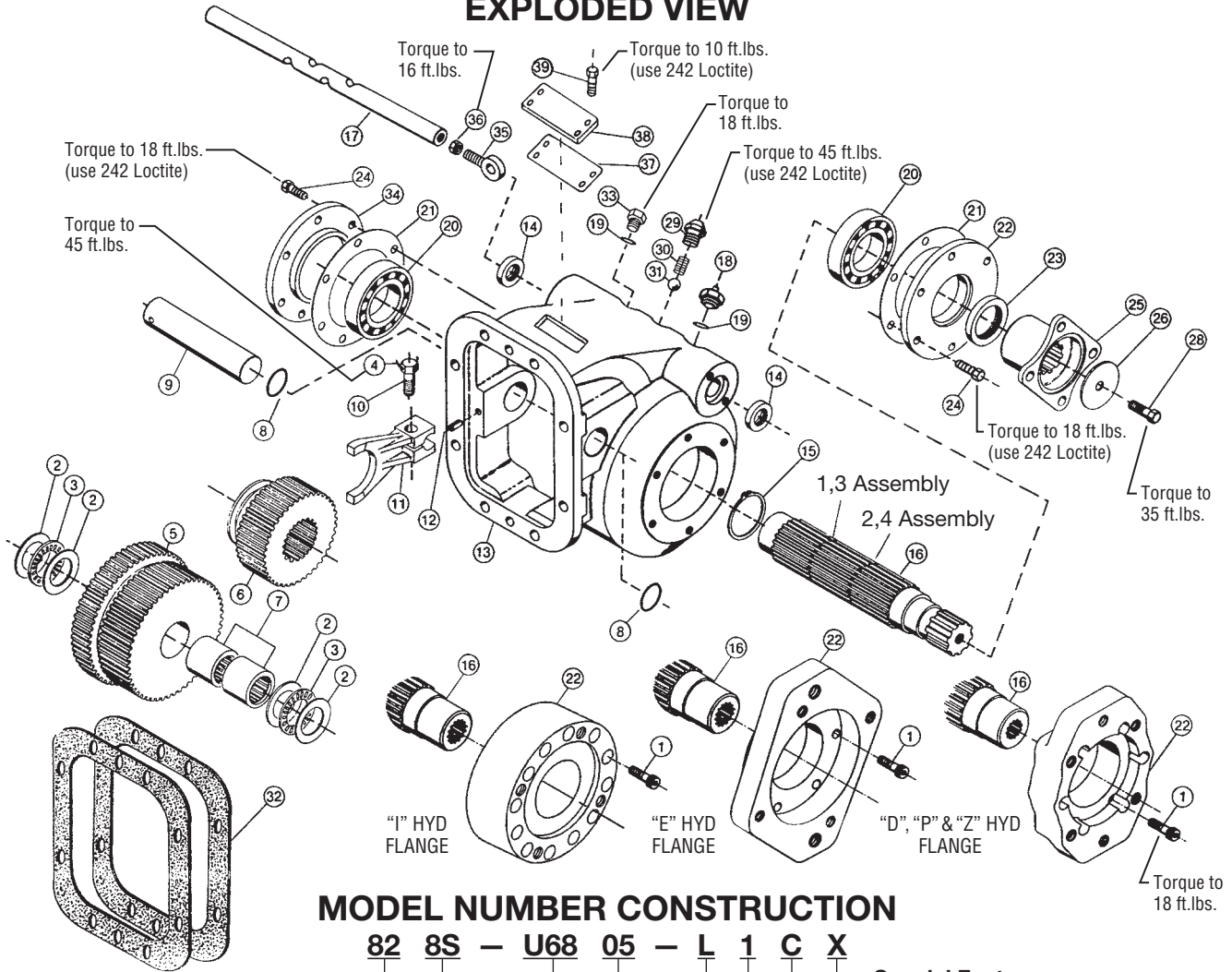

MODEL NUMBER CONSTRUCTION

82 8S - U68 05 - L 1 C X

PTO Type

8-Bolt 82 Series — 82

Mountings

SAE 8-Bolt Std. Mtg. — 8S
 SAE 8-Bolt Std. Mtg., Metric Stud Kit — 8B
 SAE 8-Bolt Std. Mtg., (Roller Bearings) — 8R

Transmission 82 Gear Data

Fuller	10.1 P 21.5° PA Spur	-F11
Fuller	6 or 6/8 P 20° Spur	-F68
Mack	6.48 P 17° 30' Spur	-M65
Spicer	7 P 17.5° 28° 4' 23" LH	-S70
Universal	5 or 5/7 P 20° Spur	-U57
Universal	6 P 25° Spur	-U62
Universal	6 or 6/8 P 20° Spur	-U68

Speed Ratios

05 — .47:1	09 — .93:1	12 — 1.15:1	15 — 1.50:1
06 — .60:1	10 — 1.00:1	13 — 1.33:1	19 — 1.89:1
08 — .75:1			

Special Features

X — None
 P — Pressure Lubrication
 G — Greaseable Shaft Option (EG,PG,ZG)

Output Types

A — SAE "D" 1 1/4" 14 Spl (Special Order)
 C — 1410 Companion Flange
 D — SAE "B"
 E — SAE "C"
 G — Metric (Special Order)
 I — DIN 5462 (B8 x 32 x 36)
 P — SAE "BB" (Same as DW/1"-15spl.)
 U — SAE "C" (Double output flanges)(Spl Order)
 2 — DIN Companion Flange
 Z — SAE "C" Shaft, SAE "B" Flange

Assy. Arrangements

1 2 3 4

Shifter Types

B — Air Shift (Special Order)
 D — Double Act. Manual Air (Dual)
 G — Air Shift (Special Order)
 L — Lever
 M — Constant Mesh
 P — Double Act. ("D" less kit)
 Q — Double Act. Manual Air (Single)
 U — Double Act. Air ("Q" less act. kit)
 V — Double Acting Electric/Air

PARTS LIST AND DESCRIPTION

ITEM	QTY	PART NUMBER	DESCRIPTION
1	6	19T31577	Socket Head Capscrew (Hyd
	6	19T35386	Only) Socket Head Capscr.
2	4	10T34715	("A","I" Hyd) Race
3	2	10T27068	Thrust Bearing
4	1	28T21513	Lockwire
5	1	(See Below)	Input Gear
6	1	(See Below)	Output Gear
7	2	10T29491	Roller Bearing
8	2	12T35622	O-Ring
9	1	07T35667	Idler Shaft
10	1	19T32326	Capscrew
11	1	28T32756	Yoke
12	1	26T26112	Roll Pin
13	1	01T34689	Housing (828S)
14	2	11T36865	Shift Rod Seal
15	1	24T26980	Snap Ring
16	1	06T34722	Std. Output Shaft (1½ Spl) "A"
		06T36494	Hydraulic Shaft (Spl Order) "D"
		06T34691	Hydraulic Shaft
		06T42024	"E" & "Z" Hydraulic Shaft
		06T37653	"G" Hydraulic Shaft (Spl Order)
		06T38211	"I" Hydraulic Shaft (B8x32x36)
		06T17327	"P" Hydraulic Shaft
		06T35327	"U" Hydraulic Shaft
		06T39307	"PG" Hyd Shaft (See Page 4)
		06T39308	"EG, ZG" Hyd Shaft (See Page 4)
17	1	17T36454	Shift Rod
18	1	30T38110	Indicator Switch - Black
19	2	12T36526	O-Ring
20	2	10T35775	Ball Bearing
		10T40301	Roller Bearing (828R)

ITEM	QTY	PART NUMBER	DESCRIPTION
21	2	13T31494	Gasket
22	1	15T34719	Open Bearing Cap (C, 2, X)
		14T36565	"A" Hyd Flg (SAE "D")(Spl Order)
		14T34693	"D","P"&"Z" Hyd Flange (SAE "B")
		14T42754	"E","G","U" Hyd Flange (SAE "C")
		14T36834	"I" Hyd Flange (DIN 5462)
23	1	11T64141	Shaft Seal
24	12	19T34717	Hex Head Cap Screw
			(Only 6 needed for hyd assy's)
25	1	14T31499	Flange ("C")
		14T37498	Flange ("2")
26	1	21T20092	Flat Washer (C, 2, X)
28	1	19T38266	Hex Head Capscrew
29	1	28T22019	Poppet Retainer Cap
30	1	27T22021	Spring (not used in air shift)
31	1	28T20486	Poppet Ball (not used in air shift)
32	2	13M35151	.010 8-Bolt Gasket
	1	13M35152	.020 8-Bolt Gasket
33	1	25T32143	Plug
34	1	15T31492	Closed Bearing Cap
		15T39321	Cover "EG" (See Page 4)
35	1	28T34746	Eyebolt
36	1	22T21723	Nut
37	1	13T34022	Gasket
38	1	16T33999	Cover, Inspection
39	4	19T34028	Hex Head Cap Screw
N.S.	1	82-GSK	Gasket & Seal Kit
			Items 8(2), 14(2), 19(2), 21(2), 23(1), 32(3), 37(1), 25T34624(2)
N.S.	1	82-RBK	Rebuild Kit
N.S.	1	82-RBKR	Rebuild Kit (Roller Bearing)
N.S.	1	18M18820	Constant Mesh Sleeve (See Page 5)
N.S.	-	07TK4609	Input Shaft Kit
			Includes Items 2, 3, 7, 8, 9, 12

PTO MODEL	ITEM 5 INPUT GEAR (TEETH)	ITEM 6 OUTPUT GEAR (TEETH)
F1119	03T35670 (61)	02T35671 (32)
F6819	03T36562 (36)	02T35615 (19)
M6508	03T39283 (37/24)	02T34694 (32)
M6510	03T34706 (37/28)	02T34695 (28)
M6513	03T34707 (37/32)	02T32764 (24)
M6519	03T35616 (39)	02T35617 (21)
S7010	03T34713 (35/28)	02T34695 (28)
S7013	03T34714 (35/32)	02T32764 (24)

PTO MODEL	ITEM 5 INPUT GEAR (TEETH)	ITEM 6 OUTPUT GEAR (TEETH)
U5713	03T35158 (28/32)	02T32764 (24)
U6205	03T34698 (34/18)	02T34467 (38)
U6206	03T35313 (34/21)	02T35314 (35T)
U6208	03T34699 (34/24)	02T34694 (32)
U6210	03T34700 (34/28)	02T34695 (28)
U6212	03T35921 (34/30)	02T35922 (26)
U6805	03T34701 (34/18)	02T34467 (38)
U6808	03T34702 (34/24)	02T34694 (32)
U6809	03T37358 (34/27)	02T37359 (29)
U6810	03T39281 (34/28)	02T34695 (28)
U6812	03T37356 (34/30)	02T35922 (26)
U6813	03T39282 (34/32)	02T32764 (24)
U6815	03T37354 (35/33)	02T37355 (22)
U6819	03T35614 (36)	02T35615 (19)

ASSEMBLY ARRANGEMENTS

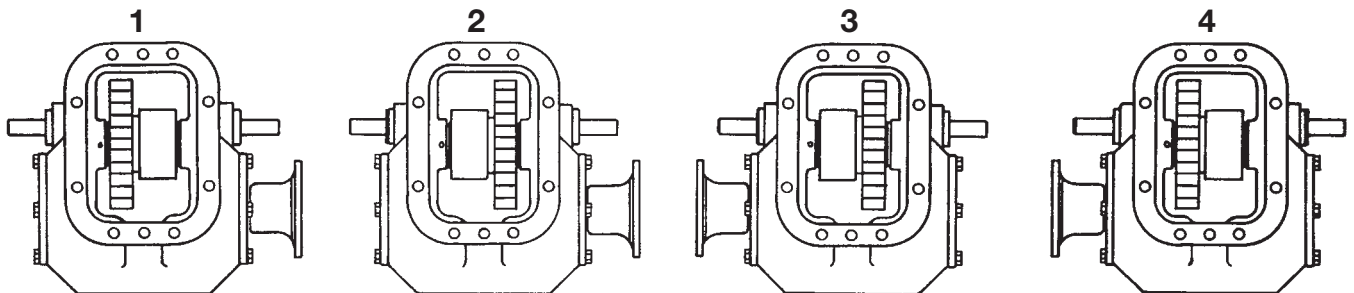

MOUNTING DIMENSIONS

MODEL	A	B	C	D	E	F	G	H
828S (mm)	3.00 (76.2)	6.81 (173.0)	0.834 (21.2)	5.58 (142.7)	3.68 (93.5)	5.06 (128.5)	7.70 (195.6)	2.00 (50.8)
828D (mm)	1.21 (30.7)	5.02 (127.5)	1.650 (41.9)	5.69 (144.5)	4.25 (107.9)	5.77 (146.6)	5.69 (144.5)	1.18 (30.0)

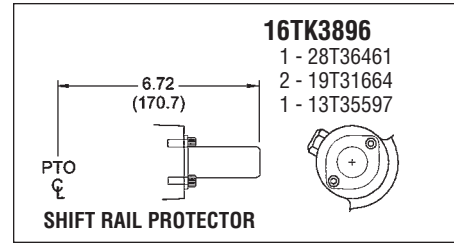

POSITIVE SHIFT INDICATOR LIGHT SWITCH LOCATION

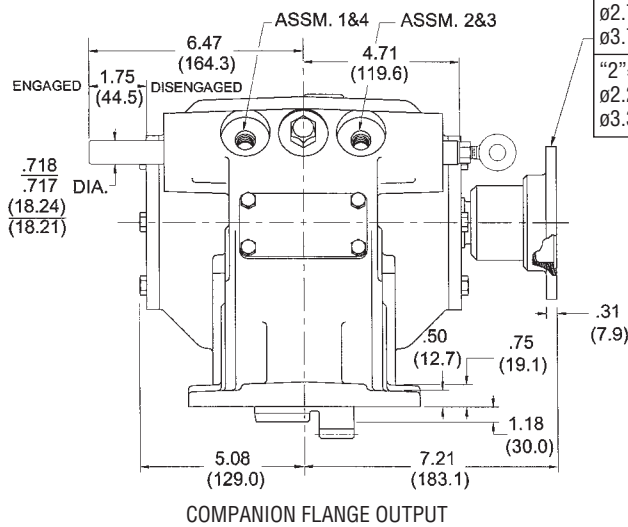

"C" = 1410 Series
 ø2.75 (70.0) Pilot (Female)
 ø3.75 (95.1) Pilot B.C.

"2" = DIN Comp. Flange
 ø2.24 (57.0) Pilot (Male)
 ø3.31 (84.0) Pilot B.C.

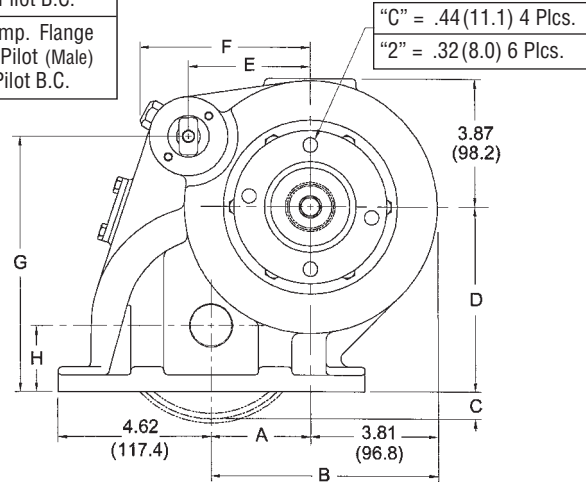

82 SERIES GREASEABLE OUTPUT SHAFT OPTION

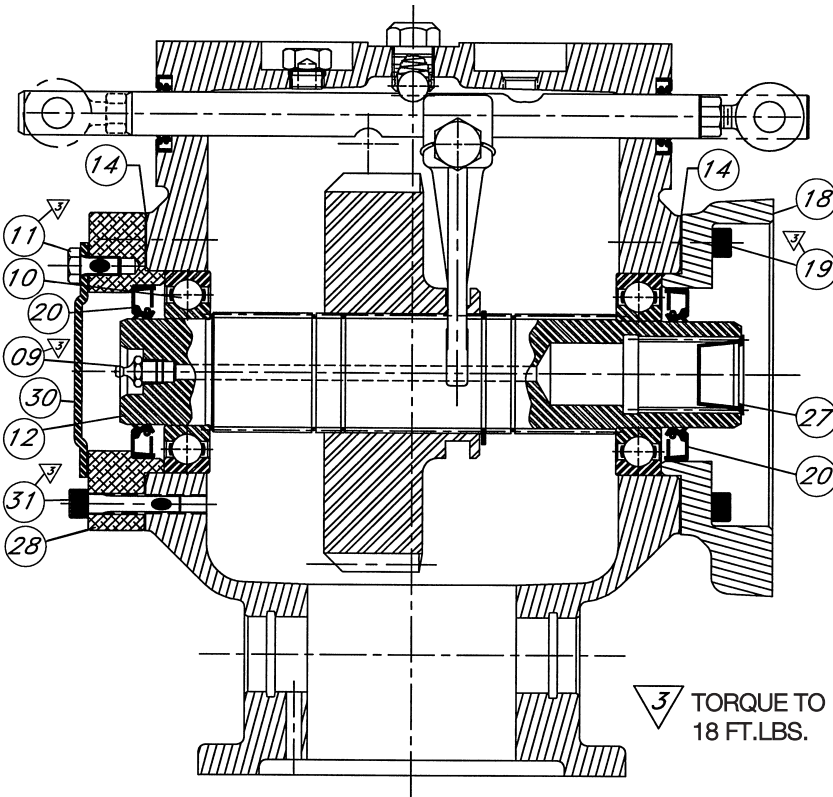

ITEM	QTY	PART NO.	DESCRIPTION
09	1	43T37236	Zerk
10	2	10T35775	Output Bearing
11	4	19T33134	Hexhead Cap Screw
12	1	06T39308	Output Shaft (EG, ZG Option Code)
		06T39307	Output Shaft - PG
14	2	13T31494	Gasket
18	1	14T31574	Hyd. Flange - E
		14T34093	Hyd. Flange - P or Z
19	6	19T31577	Sockethead Cap Screw
20	2	11T64141	Output Shaft Seal
27	1	25T35936	Cap Plug
28	1	15T39321	Cover
30	1	15T34323	Closed Bearing Cap
31	6	19M84478	Cap Screw

82 SERIES ASSEMBLY ARRANGEMENTS

Relative locations of the shift rail and indicator switch compared to the output shaft & gear (C) and input gear (D) for the various 82 Series arrangements. Position the shift rail in the housing so that the position of (A) and (B) notches on the rail are in the position shown for the appropriate assembly required.

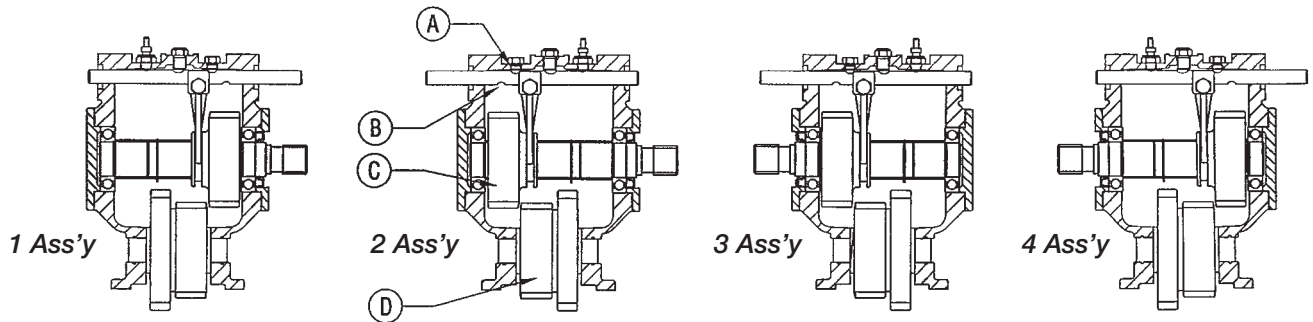

CONSTANT MESH

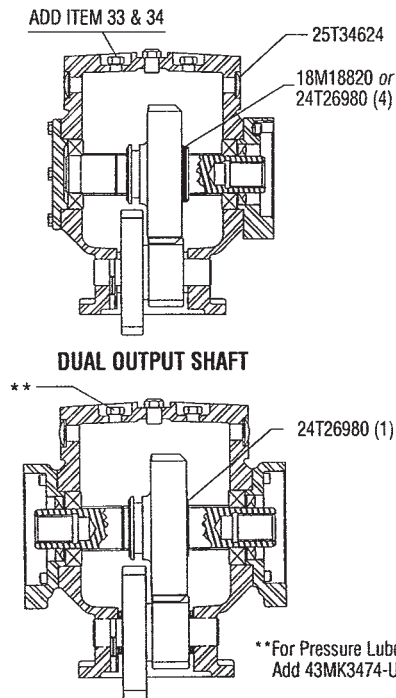

19 RATIO ASSEMBLY

The 19 ratio requires the shift rail capscrew to be installed from the backside of the fork.

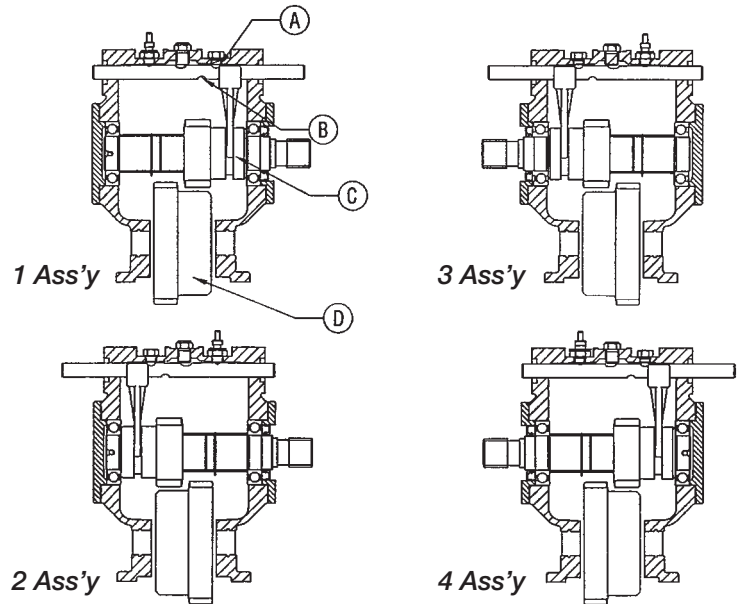

82 SERIES SHIFT FORK ASSEMBLY

The assembly of the 19-ratio 82 Series PTO is unique because of the way this unit engages. The output gear engages directly with the input gear rather than with a cluster gear as on other 82 Series units.

To assemble a 19-ratio unit, the shift fork is flipped 180 degrees and moved to the opposite side of the housing. The shift fork capscrew is installed by reaching through the output shaft/bearing hole. The output shaft has been modified to include four snap ring grooves. A snap ring is installed to serve as a gear stop.

The drawings show a comparison of the standard and 19-ratio units. The 1 and 4 assemblies are illustrated here.

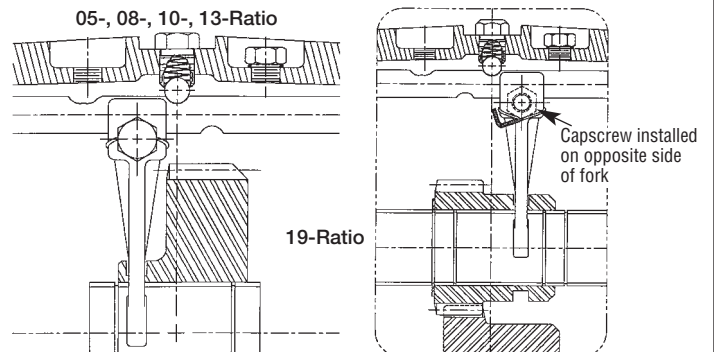

HYDRAULIC ASSEMBLIES

"A" Hydraulic Assembly

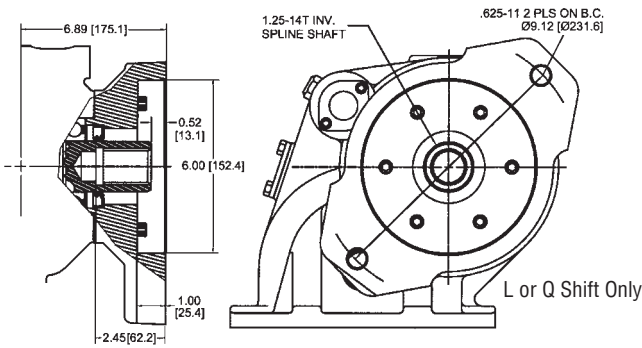

"D", "P", & "Z" Hydraulic Assembly

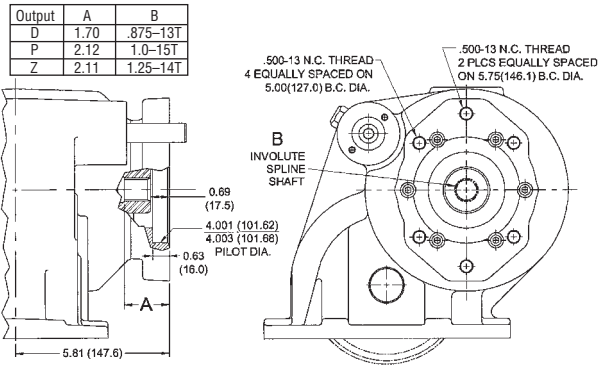

"E" Hydraulic Assembly

Mount Air/Shift
Opp. Shaft on "E" Only

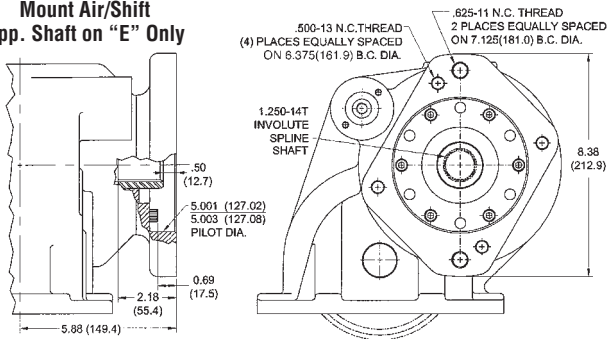

"I" Hydraulic Assembly

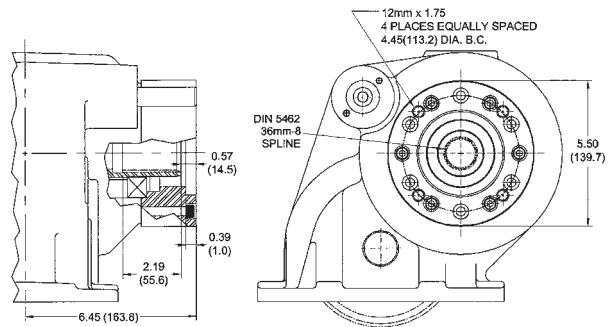

AIR SHIFT CYLINDERS

47TA3978 DOUBLE ACTING / SINGLE CYLINDER ("Q", "B", "G", & "U" OPTION)

(Includes Shift Rail Protector 16TK3896)

(Cylinder mounts to same side as output shaft, except "A" or "E" output)

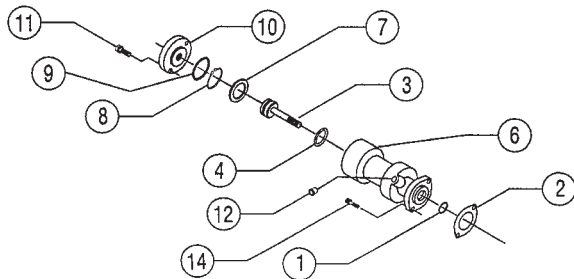

ITEM	QTY	PART NUMBER	DESCRIPTION
1	1	12T35611	O-Ring
2	1	13T35597	Gasket
3	1	28TA3862	Piston Assembly**
4	1	12T35621	O-Ring
6	1	28T35599	Housing
7	1	18T36818	Spacer
8	1	24T35623	Snap Ring
9	1	12T35622	O-Ring
10	1	28T35689	End Cap
11	2	19T34494	Cap Screw*
12	2	25T34029	Cap Plug
14	2	19T35624	Cap Screw*

* Torque capscrews to 9 ft.lbs.
** Torque to 20 ft.lb. when installing on PTO Shifter Shaft.

47TK3899 DOUBLE ACTING / DUAL CYLINDERS ("D", "V", & "P" OPTION)

(Kit includes two cylinders.
One cylinder mounts to each side of the PTO)

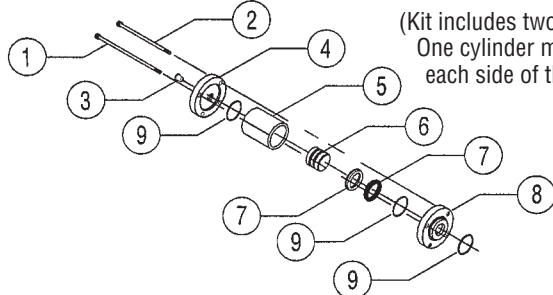

ITEM	QTY	PART NUMBER	DESCRIPTION
1	4	19T36476	Cap Screw (3/4)*
2	4	19T36474	Cap Screw (3/8)*
3	2	25T34029	Cap Plug
4	2	28T36460	End Cap Cover
5	2	28T36475	Cylinder Body
6	2	49T35204	Piston
7	4	28T65140	U-Cup Seal
8	2	28T36458	Nose Cap Cover
9	6	12T36456	O-Ring

* Torque cap screws to 9 ft.lbs.

82 SERIES DOUBLE ACTING AIR SHIFT SYSTEM (OPTIONS "D" & "Q")

Installation Kit: **48M61261-A** (12V Light)

Conversion Kit Number – Lever to Double Acting Air (12 V only listed) **16MK3253-A** (Includes 47TK3899 Air Cylinder)

OPTION "D" DIAGRAM

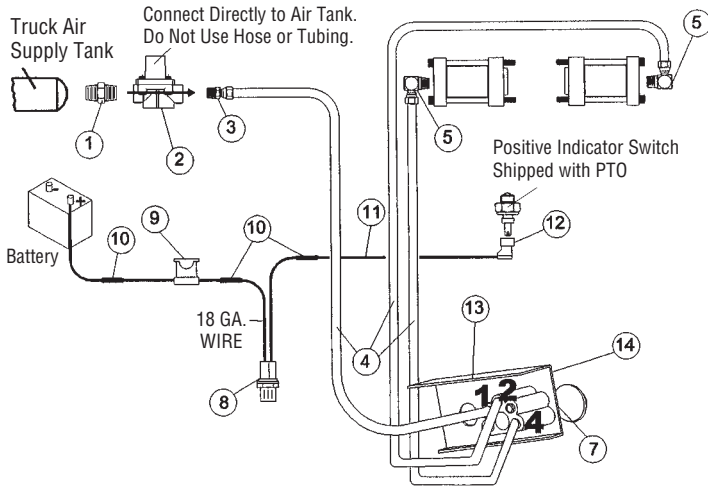

ITEM	QTY	PART NUMBER	DESCRIPTION
1	1	44MB2164	Nipple
2	1	31M15759	Pressure Protect. Valve
3	1	44MB6844	Tube Fitting
4	1	45M44430	Air Tubing - 30'
5	2	44MB6942	Tube Fitting (Elbow)
6	1	44MB6842	Tube Fitting
7	1	35T37955	Air Valve
8	1	32M12001	12 V Light
		32M24001	24 V Light
9	1	33T36299	Fuse Holder
10	3	34M18002	Butt Splice
11	1	37T42512	Electric Wire
12	1	34T38163	Booted Connector
13	1	36T38049	Dash Bracket
14	1	36T38016	Face Plate
N.S.	1	36MK1007	Cap Screw Bolt Kit

OPTION "Q" DIAGRAM

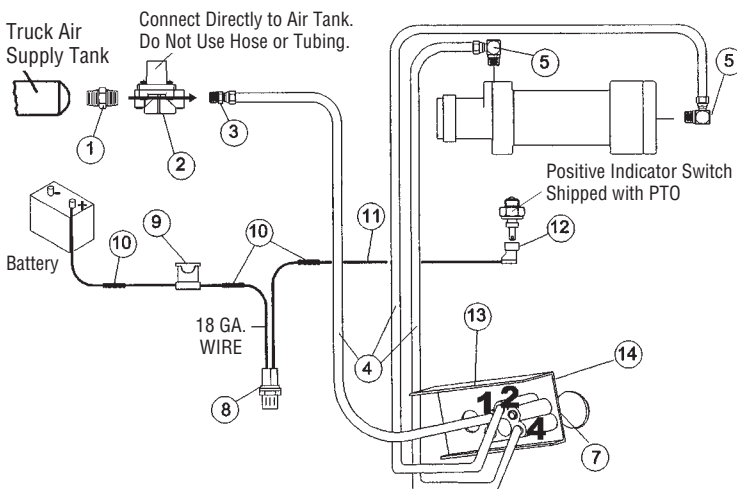

Note: For B, D, G, Q & V Options

When installing Air Shift System, remove Poppet Ball (31) and Spring (30) shown on page 3. Reseal Poppet Retainer Cap (29) before reinstalling, using Loctite 242 or equivalent.

82 Series Double Acting Air Shift Option "B" Activation Kit
48T38574 Using
47TA3978 Cylinder (Single)

Conversion Kit:
 Lever to "Q"
 Double Acting Air
16MK3252A



Instructions For Push/Pull Manual Air Valve

1. Remove the button cover (5) from the end of the air valve.
2. Using $\frac{3}{32}$ " allen wrench remove screw (4) from knob. Hold red knob (3) to loosen screw.
3. Pull the red knob (3) from the valve stem.
4. Unscrew the hex nut (2) from the valve (1).
5. Install the valve (1) through the bracket (6) and face plate (7) using hex nut (2) to hold in place.
6. Place knob (3) over the valve stem, aligning the pin in the groove of the knob (3).
7. Insert screw (4) and tighten with $\frac{3}{32}$ " allen wrench.
8. Push the button cover (5) onto the knob (3).

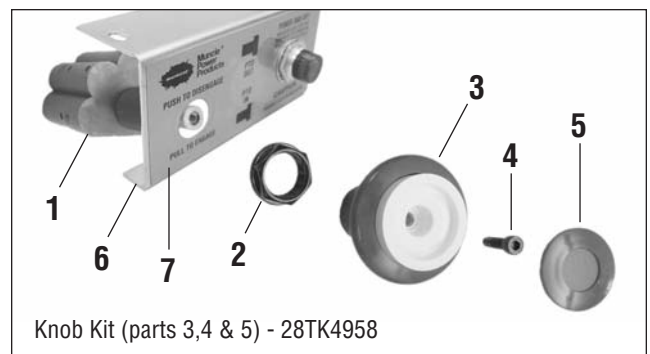

82 SERIES DOUBLE ACTING ELECTRIC/AIR SHIFT SYSTEM (OPTION "V")

Installation Kit: **48T37421-A** (12 V Light)

Conversion Kit Number – Lever to Double Acting Electric/Air (12 V only listed) **16TK3952-A** (Includes 47TK3899 Air Cylinder)

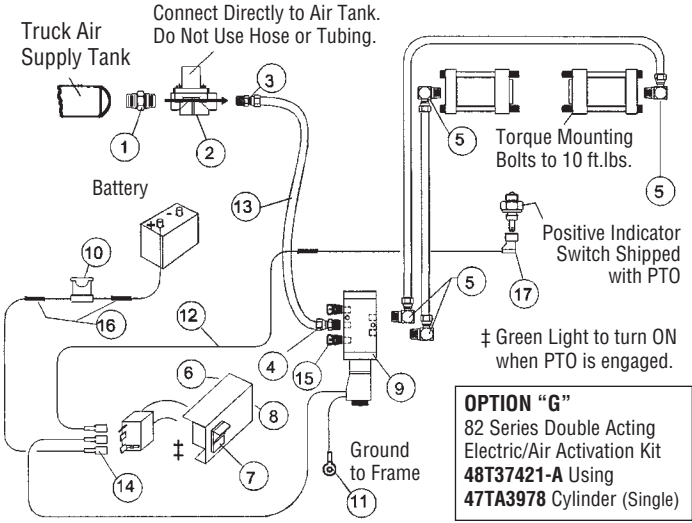

ITEM	QTY	PART NUMBER	DESCRIPTION
1	1	44MB2164	Nipple
2	1	31M15759	Pressure Protect. Valve
3	1	44MB6844	Tube Fitting
4	1	44MB6842	Tube Fitting
5	4	44MB6942	Tube Fitting (Elbow)
6	1	36MA1005	Dash Bracket
7	1	30T35687	Switch & Light Ass'y
8	1	36M01007	Face Plate
9	1	35T41078	Solenoid Valve
10	1	33T36299	Fuse Assembly
11	1	34M18009	Ring Terminal
12	12	37M18000	Electric Wire - 12'
13	1	45M44430	Air Tubing - 30' (9.14M)
14	3	34M18250	Female Spade Connector
15	2	44M30137	Breather
16	3	34T36362	End Crimp
17	1	34T38163	Booted Connector
N.S.	1	36MK1007	Bolt Kit
N.S.	1	34T41079S	Wire Harness

MOUNTING KITS

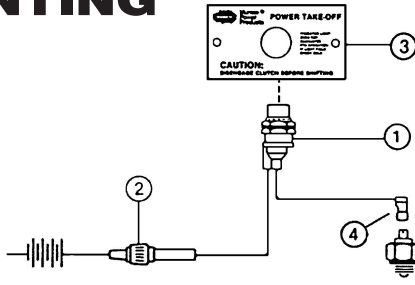

DASH LIGHT KIT 36MK1210-A

ITEM	QTY	PART NUMBER	DESCRIPTION
1	1	32M12001	Indicator Light
2	1	33T36299	Fuse Holder
3	1	36M16818	Dash Face Plate
4	1	34T38163	Booted Connector

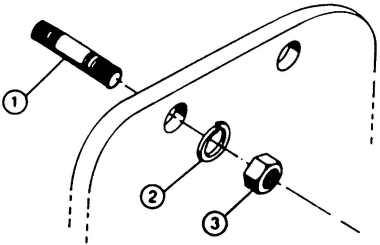

8-BOLT MOUNTING KIT 20MK8815 (828S)

ITEM	QTY	PART NUMBER	DESCRIPTION
1	8	20M44213	Stud
2	8	21ML4375	Lock Washer
3	8	22MX4420	Hex Nut

8-BOLT MOUNTING KIT 20MKM802 (828B)

ITEM	QTY	PART NUMBER	DESCRIPTION
1	8	20M47055	Stud, Metric
2	8	21ML4375	Lock Washer
3	8	22MX4420	Hex Nut

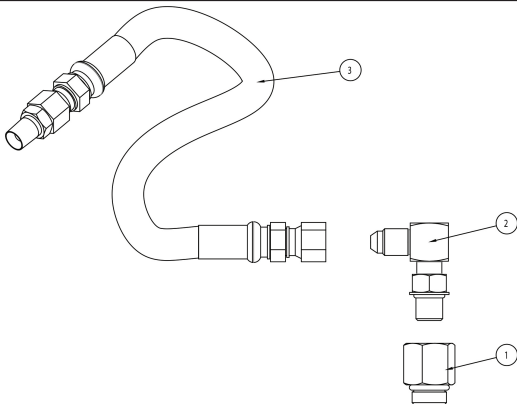

PRESSURE LUBE KIT 43MK3474

ITEM	QTY	PART NUMBER	DESCRIPTION
1	1	43T42006	Reducer Fitting
2	1	43T42012	Orifice Elbow
3	1	45T42015	Hose
43MK3474-U (for "U" Output Option)			
1	1	43M02203	Orifice Fitting
2	1	45M4R536	Hose
N.S.	1	43MBMP64	Adapter
N.S.	1	44MB0942	Adapter



A Member of the Interpump Group

SP83-03 (Rev. 03-22)

201 East Jackson Street, Muncie, Indiana 47305
800-367-7867 • Fax: 765-284-6991 • info@munciepower.com

Specifications are subject to change without notice. Visit www.munciepower.com for warranties and literature. All rights reserved. © Muncie Power Products, Inc. (2008)