

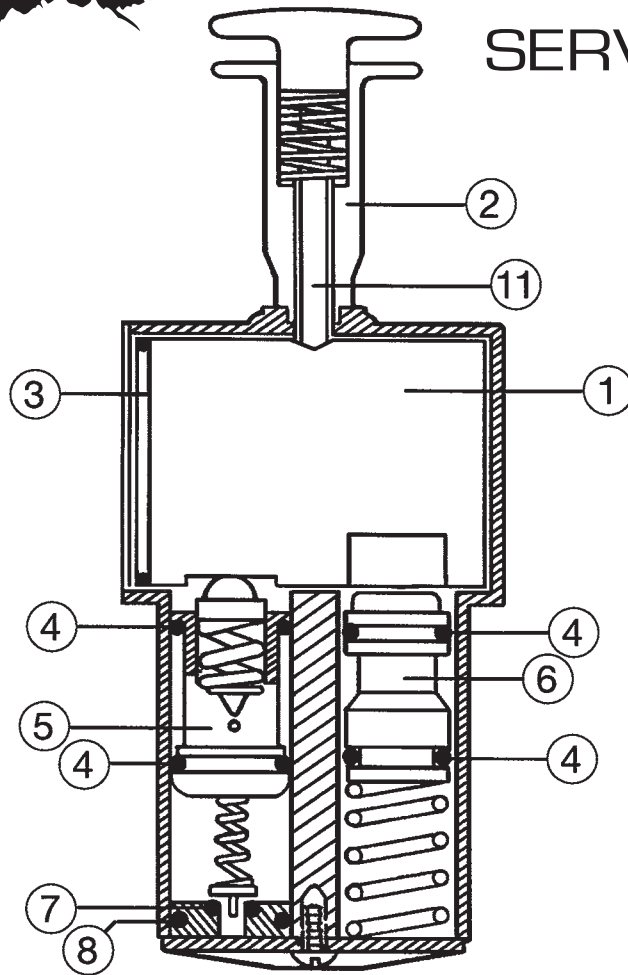

# 1461AM AIR CONTROL VALVE REBUILD

## SERVICE PARTS LIST



Parts are not available individually.

**Note:** White Teflon or Lithium type grease should be used on all O-Rings before assembly.

Only new style valves can be serviced with these repair kits built after May 1989 (Build codes 27866, 27879 and later). Valves using a Shrader valve design (Tire valve stem) cannot be serviced.

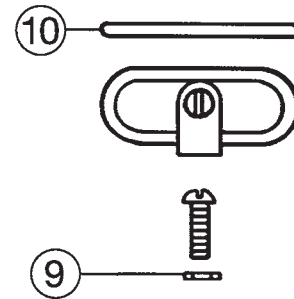

### PARTS LIST AND DESCRIPTION

RBK-1461AM REBUILD KIT		
ITEM	QTY	DESCRIPTION
1	1	Cam
2	1	Detent Sleeve
3	1	O-Ring – Cam
4	4	O-Ring – Piston
5	1	Piston (Lower)
6	1	Piston (Raise)
7	1	O-Ring – Exhaust Seat
8	1	O-Ring – Seat Retainer
9	1	O-Ring – Screw
10	1	O-Ring – Manifold

GSK-1461AM MINOR PISTON/SEAL KIT		
ITEM	QTY	DESCRIPTION
3	1	O-Ring – Cam
4	4	O-Ring – Piston
5	1	Piston (Lower)
7	1	O-Ring – Exhaust Seat
8	1	O-Ring – Seat Retainer
9	1	O-Ring – Screw
10	1	O-Ring – Manifold

1462A STEEL SHANK HANDLE KIT		
ITEM	QTY	DESCRIPTION
11	1	Knob, Shank & Spring Assembly



SP90-01 (Rev. 2-98) Printed in the U.S.A.  
© Muncie Power Products, Inc. 1998

Muncie Power Products, Inc. Member of the Interpump Hydraulics Group  
General Offices and Distribution Center • P.O. Box 548 • Muncie, IN 47308-0548  
(765) 284-7721 • FAX (765) 284-6991 • E-mail info@munciepower.com  
Web site <http://www.munciepower.com>

Drive Products, Exclusive Agents for Canada, ISO Certified by an Accredited Registrar

