

FR66 SERIES

POWER TAKE-OFF FOR THE FORD TORQSHIFT®



THE PROVEN LEADER IN DURABILITY

Muncie's updated FR66 power take-off gives you the versatility of mounting larger hydraulic pumps to handle a variety of heavy duty jobs. Our PTO utilizes a one-piece housing design with forced lubrication for increased durability and simplified installation. The FR66 incorporates patented noise suppression technology, integral mobile or stationary functions and a higher torque capacity of 200 lbs.ft.

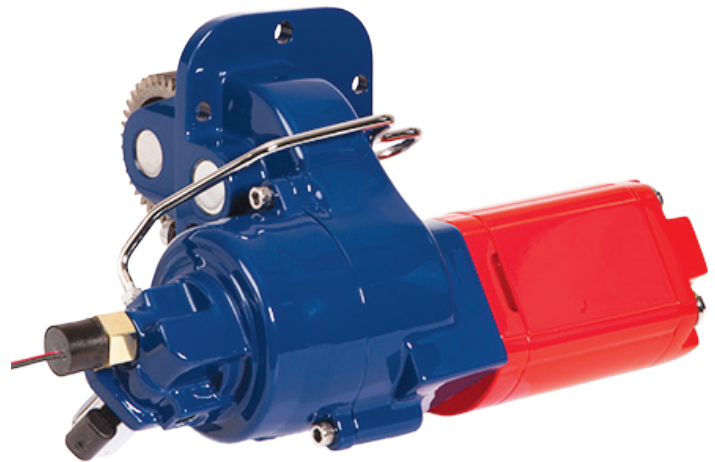

KEY FEATURES

- Using patented technology
- Higher torque capacity of 200 lbs.ft.
- Increased durability
- The new benchmark for noise reduction
- One-piece housing, fewer leak points
- Complete integrated wiring harness
- SAE "A" flange
- SAE "B" shaft

PTO TORQUE & HORSEPOWER RATINGS

SPEED RATIO	INTERMITTENT HP@ 1,000 RPM	INTERMITTENT TORQUE LBS.FT.	CONTINUOUS TORQUE LBS.FT.	INTERMITTENT (KW) @ 1,000	INTERMITTENT TORQUE (NM)	CONTINUOUS TORQUE (NM)
09	39	200	140	(29)	(271)	(190)
09	22	*120	120	(16)	(182)	(162)

Approximate Weight: 28 lbs. (12.7 Kg.)

*FR66 limit in mobile applications continuous intermittent.

DIMENSIONS

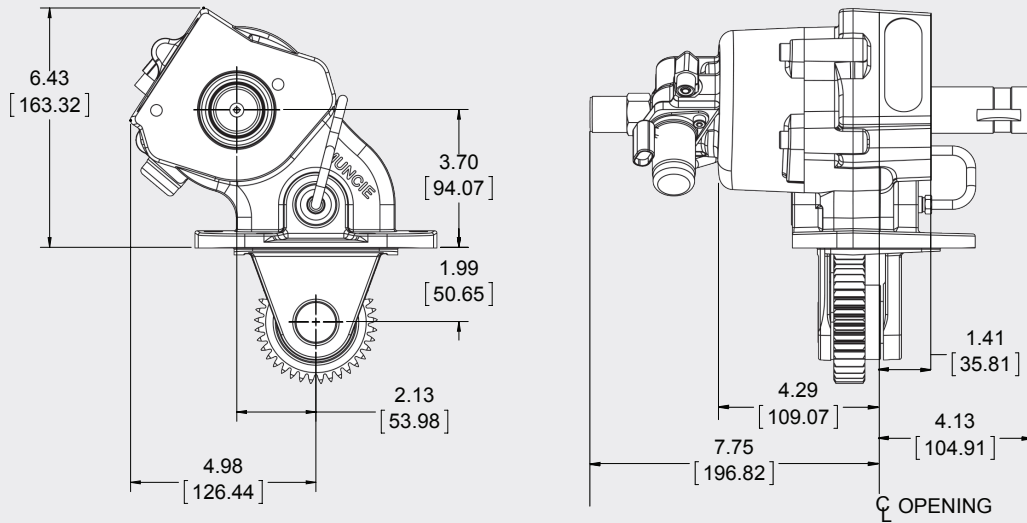

MODEL NUMBER CONSTRUCTION

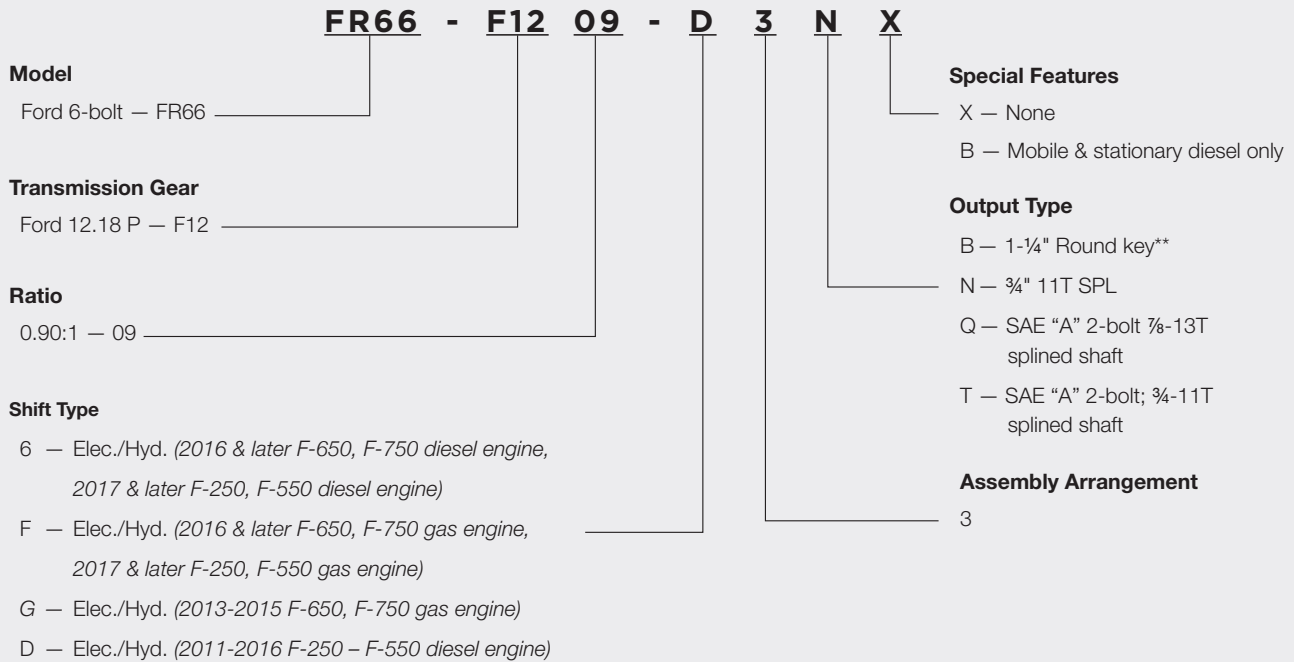

** Driveline output is not recommended on 4x4 chassis.

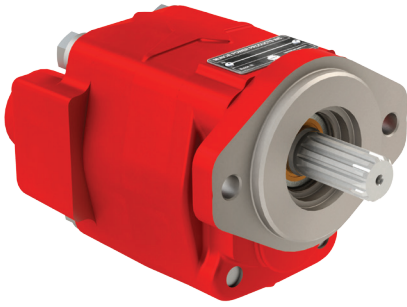

H SERIES

Modifications to the H Series pump rear cover will allow optimum compatibility with FR66 “Q” mount applications. Enhanced design features, including elimination of side ports and the removal of nearly ½” of material from the suction side of the housing, provide increased clearance of the floorboard.

All standard H Series displacements will be available for FR66 “Q” mount applications. Each unit will come standard with a SAE “A” 2-bolt mounting flange and 7/8” - 13T splined shaft.

MODEL NUMBER	DISPLACEMENT IN ³ (CC)	MAX* RPM	MIN* RPM	MAX PRES PSI (BAR)	INLET (SAE)	OUTLET (SAE)	MAX INLET VACUUM
PH1-03-02ASRL-M	0.62 (10)	3,500	1000	3,500 (241)	1.25	0.75	5 in.hg.
PH1-05-02ASRL-M	1.24 (20)	3,500	800	3,500 (241)	1.25	0.75	5 in.hg.
PH1-07-02ASRL-M	1.55 (25)	3,250	800	3,500 (241)	1.25	0.75	5 in.hg.
PH1-08-02ASRL-M	1.86 (30)	3,000	800	3,250 (224)	1.25	0.75	5 in.hg.
PH1-09-02ASRL-M	2.17 (36)	3,000	800	2,900 (200)	1.25	0.75	5 in.hg.
PH1-11-02ASRL-M	2.48 (41)	3,000	800	2,500 (172)	1.25	0.75	5 in.hg.

Note: Use H Series pumps on 4x2 chassis applications only.



W SERIES

Modifications to the W Series pump housing allow compatibility with the FR66 “Q” mount on the F-650/F-750 applications. The W Series robust design allows higher operating pressures than typical gear pump applications.

All standard “W” displacements are available for the FR66 “Q” mount. Each unit will come standard with a SAE “A” 2-bolt mounting and a 7/8” 13T splined shaft.

MODEL NUMBER	DISPLACEMENT IN ³ (CC)	MAX* RPM	MIN* RPM	MAX PRES PSI (BAR)	PORTS (SAE) SIDE & REAR	PORTS (SF) SIDE ONLY	MAX INLET VACUUM
W06-02AJ0-GIGI-F14	1.45 (23.9)	3,600	800	4,350 (300)	- 16	1.50" X 1.00"	5 in.Hg.
W08-02AJ0-GIGI-F14	1.96 (32.2)	3,600	600	4,350 (300)	- 16	1.50" X 1.00"	5 in.Hg.
W11-02AJ0-GIGI-F14	2.42 (39.7)	3,250	600	4,350 (300)	- 16	1.50" X 1.00"	5 in.Hg.
W13-02AJ0-GTGT-F14	2.92 (47.9)	3,000	600	4,000 (275)	- 20	2.00" X 1.25"	5 in.Hg.
W15-02AJ0-GTGT-F14	3.46 (56.8)	2,750	600	3,750 (260)	- 20	2.00" X 1.25"	5 in.Hg.
W17-02AJ0-GTGT-F14	3.96 (65.0)	2,500	600	3,500 (240)	- 20	2.00" X 1.25"	5 in.Hg.
W19-02AJ0-GTGT-F14	4.37 (71.6)	2,500	600	3,250 (225)	- 20	2.00" x 1.25"	5 in.Hg.
W21-02AJ0-GTGT-F14	4.87 (79.8)	2,500	600	3,000 (210)	- 20	2.00" x 1.25"	5 in.Hg.

Note: Use W Series pumps on F-650, F-750 chassis only.

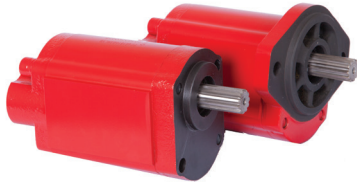

F4 SERIES

Ultimate power and performance in a small package best describes the all new F4 Series gear pumps. The pressure balanced bushing blocks and sleeve bearings provide both extra long life and high performance.

MODEL NUMBER	DISPLACEMENT IN ³ (CC)	MAX* RPM	MIN* RPM	MAX PRES PSI (BAR)	O.D.T.** INLET REAR	O.D.T.** INLET SIDE	MAX INLET VACUUM	DIRECT MOUNT PUMP USE PF4-***16QSRL	PUMP FLOW @ 1200 ENG. (THEORETICAL)
PF4-107	0.24 0(4)	3,500	1,000	3,625 (250)	1 1/16	1 5/16	6 in.Hg.	—	—
PF4-160	0.37 0(6)	3,500	900	3,625 (250)	1 1/16	1 5/16	6 in.Hg.	—	2.4 GPM
PF4-212	0.49 0(8)	3,500	900	3,625 (250)	1 1/16	1 5/16	6 in.Hg.	—	3.2 GPM
PF4-264	0.61 (10)	3,500	800	3,625 (250)	1 1/16	1 5/16	6 in.Hg.	—	4.0 GPM
PF4-290	0.67 (11)	3,500	800	3,625 (250)	1 1/16	1 5/16	6 in.Hg.	—	4.4 GPM
PF4-368	0.85 (14)	3,500	600	3,625 (250)	1 1/16	1 5/16	6 in.Hg.	—	5.6 GPM Auto Loader*
PF4-424	0.98 (16)	3,500	600	3,625 (250)	1 1/16	1 5/16	6 in.Hg.	6.5 GPM	—
PF4-502	1.16 (19)	2,750	600	3,625 (250)	1 1/16	1 5/16	6 in.Hg.	7.7 GPM	—
PF4-606	1.40 (23)	2,350	600	3,400 (235)	1 1/16	1 5/16	6 in.Hg.	9.2 GPM	—
PF4-714	1.65 (27)	2,350	600	2,750 (190)	1 1/16	1 5/16	6 in.Hg.	10.9 GPM Small Wrecker*	—
PF4-818	1.89 (31)	2,000	600	2,400 (165)	1 1/16	1 5/16	6 in.Hg.	12.5 GPM	—
PF4-870	2.01 (33)	2,000	600	2,250 (155)	1 1/16	1 5/16	6 in.Hg.	13.3 GPM Roll-Off*	—

* Maximum RPM shown at 0 In.Hg. Vacuum for -16 side inlet port.

** Port thread size shown

Notes: For Ford TorqShift® 4x4 applications, order pump code PF4-*** -16QSRL. PF4-502 & larger pump sizes are not applicable on Ford TorqShift® gas 4x4 application. Maximum oil temperature is 200°F (93.5°C). Buna N seals are standard.

*Common Applications

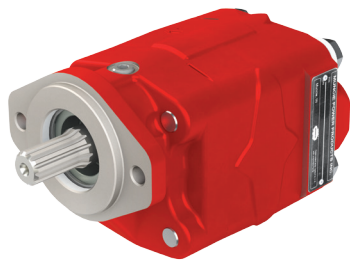

K SERIES

The K Series standard gear housing will be replaced with the S Series gear housing for use on FR66 “Q” mount applications. Elimination of side ports on the “S” gear housing significantly reduces overall width of the pump. This reduction provides increased clearance of the floorboard.

Only the 6, 13 and 17 GPM K Series models will be available for FR66 “Q” mount applications due to the limited amount of S displacements. Each unit will come standard with a SAE “A” 2-bolt mounting flange and 7/8" - 13T splined shaft.

MODEL NUMBER	DISPLACEMENT IN ³ (CC)	MAX* RPM	MIN* RPM	MAX PRES PSI (BAR)	INLET (NPT)	OUTLET (SAE)	MAX INLET VACUUM
PK1-06-02ACRL-M	1.47 (24)	3,600	600	3,000 (207)	1.00	1.00	5 in.hg.
PK1-13-02ACRL-M	2.96 (48)	2,500	600	3,000 (207)	1.00	1.00	5 in.hg.
PK1-17-02ACRL-M	3.94 (65)	2,500	600	2,500 (172)	1.00	1.00	5 in.hg.

Note: Use K Series pumps on 4x2 chassis applications only.



Member of the Interpump Group

MP15-08 (Rev. 02-17)

201 East Jackson Street • Muncie, Indiana 47305
800-367-7867 • Fax 765-284-6991 • info@munciepower.com • www.munciepower.com

Specifications are subject to change without notice. Visit www.munciepower.com for warranties and literature. All rights reserved. © Muncie Power Products, Inc. (2008)