

# S SERIES

## HOIST PUMPS



### OPTIMAL CONTROL IN A SMALL PACKAGE

The Muncie S Series hoist pump was designed specifically for use on small single or tandem axle dump trucks. The S Series hoist pump can be air, lever, or cable shifted. Options for both remote and direct mounting styles make the S Series pump adaptable to almost any small dump truck application.

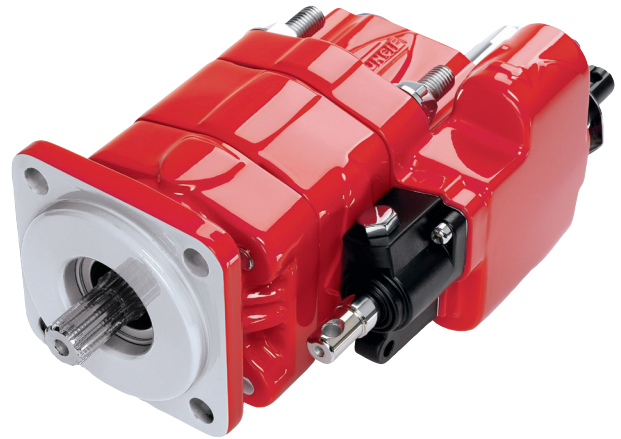

### KEY FEATURES

- 6, 11, & 15 GPM Sizes
- PTO Direct Mount or Twin Shaft Remote
- Single Acting
- Pressures to 3000 PSI (207 Bar)
- Speeds to 2500 Rpm
- Integral Valve for 2 or 3 Line System
- Anti Pull Out Safety Cap
- Built in Screw Adjust Relief Valve With Load Check
- Long Assembly Studs for Support Brackets
- Port I.D. Cap Plugs and Casting Stamp
- Optional Air or Cable Shifting
- Interchanges with Parker, Permco, and others

### 3-LINE HOIST SYSTEM

Many small hoists function quite adequately with a 2-line system. However, a 3-line system includes a separate line to return hydraulic oil from the cylinder directly to the reservoir instead of forcing its way back through the inlet line.

The separate 3rd line is the best choice because the 3-line allows faster down cycles and ultimately runs cooler.

### PUMP SPECIFICATIONS

SERIES/MODEL GPM (LITERS)	DISPLACEMENT CUBIC IN (CC)	WT.** LBS (KG)	MAX* RPM	MIN* RPM	MAX* PRES PSI (BAR)	INLET N.P.T. PORT	CYLINDER N.P.T. PORT	RETURN N.P.T. PORT
6	1.47 (24)	32 (14.8)	2500	800	3000 (207)**	1-1/4 IN.	3/4 IN.	3/4 IN.
11	2.96 (48.5)	35 (15.9)	2500	800	3000 (307)**	1-1/4 IN.	3/4 IN.	3/4 IN.
15	3.94 (65)	38 (17.2)	2500	800	2500 (172)	1-1/4 IN.	3/4 IN.	3/4 IN.

\*\* Requires high pressure relief PS1-1231VH for settings above 2500 PSI.

# MOUNTING DIMENSION SINGLE ACTING

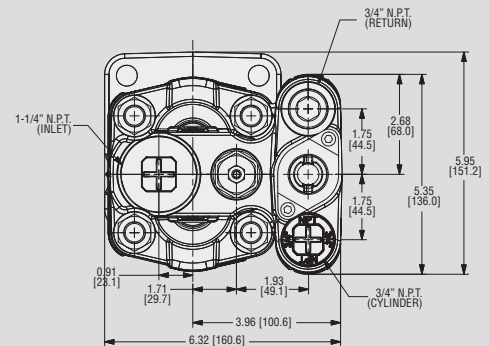
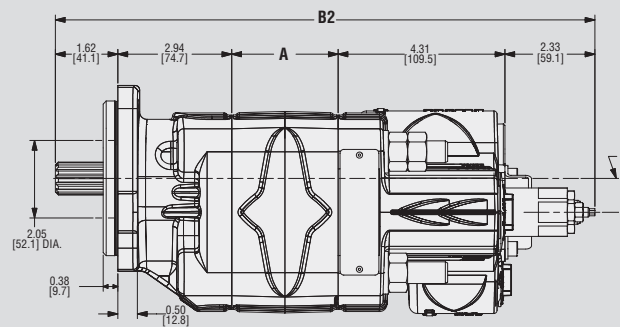
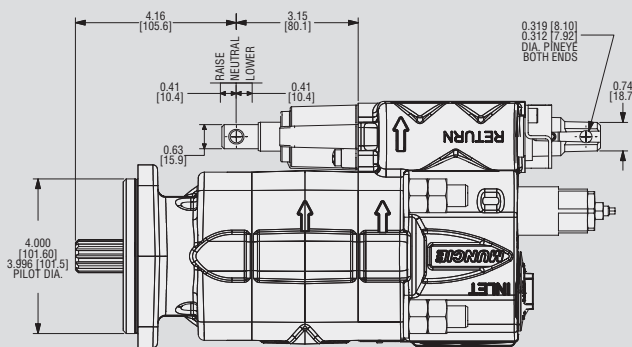
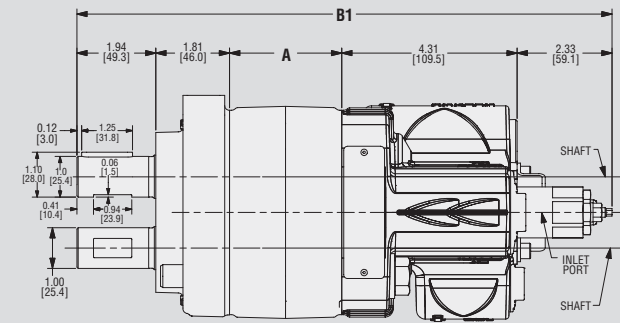
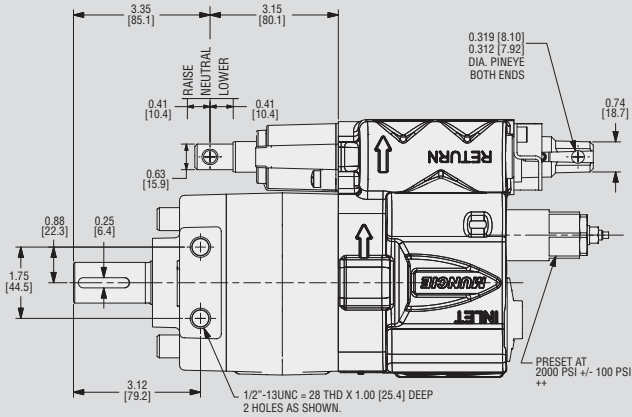

## OVERALL LENGTHS

PUMP SIZE	DIM A IN (MM)	DIM B1 IN (MM)	DIM B2 IN (MM)	WEIGHT LB (KG)
06	1.50 (38.1)	11.32 (287.5)	12.12 (307.8)	32 (14.8)
11	2.25 (57.2)	12.07 (306.6)	12.88 (327.2)	35 (15.9)
15	2.75 (69.9)	12.57 (319.3)	13.38 (339.9)	38 (17.2)

**Notes:** DO NOT USE TEFLON TAPE ON PORTS.  
 Optional Air Shift Cylinder (ACM-400 or 402).  
 Optional Conversion Sleeve for 3-Line Hookup – Muncie Part No. AA1257.  
 Tank return line must be below oil level at all times.  
 Maximum inlet vacuum is 5 in. hg. (.17 BAR).

# MODEL NUMBER CONSTRUCTION

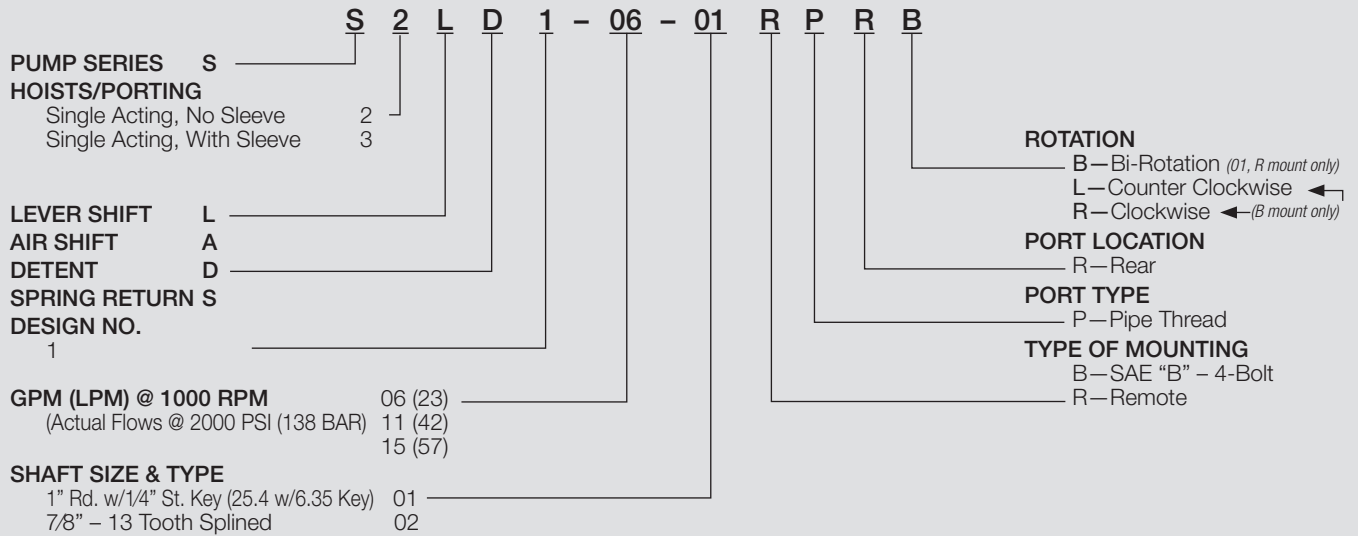

# OIL RECOMMENDATIONS

Muncie does not promote specific manufacturers' brands of oil. Recommendations below are guidelines; consult oil manufacturer for exact application needs.

**Viscosity Range:**

- Viscosity Minimum: 50-60 SUS (7.5-10.5 cST)
- Viscosity Optimum Continuous: 60-100 SUS (10.5-21.6 cST)
- Viscosity Maximum @ Startup: 7500 SUS (1600 cST)
- Viscosity Index: 90 Minimum

Aniline Point: 175 Minimum

- Pour Point: 15°F (-10°C) Maximum
- Foam Resistance: Recommended
- Rust Resistance Inhibitors: Recommended
- Corrosion Resistance: Recommended
- Oxidation Stability: Recommended
- Anti-Wear Additive: .06% Zinc Minimum\*

**Note:** Cold weather operation requires special oil considerations. Viscosity should not exceed 7500 SUS (1600 cST) at lowest startup temperature. Continuous operation should range between 60-1000 SUS (10.5-216 cST) for all temperature ranges. Never use diesel fuel or kerosene to thin oil.

\*Anti-Wear Additives may be recommended by some motor manufacturers. However, they are optional and typically not required for gear pump or gear motors.



Muncie Power Products, Inc., Member of Interpump Group  
201 East Jackson Street, Muncie, Indiana, USA 47305  
1-800-367-7867

Specifications are subject to change without notice. All rights reserved.  
Please check [www.munciepower.com](http://www.munciepower.com) for warranties and current versions of literature.  
MP15-10 (Rev. 12-14)